

Water and Wastewater Feasibility Study for the Ione Casino and Hotel

FINAL REPORT

Prepared for:

Ione Band of Miwok Indians
14 West Main Street
Ione, CA 95640

and

Analytical Environmental Services
2021 N Street, Suite 200
Sacramento, CA 95814

July 2005



Contents

1.0	Introduction	1-1
1.1	Background.....	1-1
1.2	Project Description.....	1-1
1.3	Objectives	1-5
2.0	Projected Flows.....	2-1
2.1	Wastewater Flows.....	2-1
2.2	Water Demands.....	2-7
2.3	Recycled Water.....	2-10
	2.3.1 Design Criteria.....	2-11
	2.3.2 Recycled Water Demands.....	2-11
2.4	Water Demands with Recycled Water	2-12
3.0	Water Supply	3-1
3.1	Existing Facilities.....	3-1
	3.1.1 City of Plymouth.....	3-1
	3.1.2 Amador Water Agency	3-1
3.2	Water Supply	3-1
	3.2.1 Groundwater Wells	3-1
	3.2.2 Trucking	3-2
3.3	Potable Water Demand	3-4
3.4	Water Quality	3-4
3.5	Water Facilities	3-6
	3.5.1 Water Treatment Plant	3-6
	3.5.2 Water Storage Tank and Pump Station	3-16
4.0	Regulatory Requirements.....	4-1
4.1	Background.....	4-1
4.2	Subsurface Disposal.....	4-1
4.3	Land Disposal.....	4-2
	4.3.1 Surface Water Disposal	4-2
5.0	Wastewater Facility.....	5-1
5.1	Existing Facilities.....	5-1
	5.1.1 City of Plymouth.....	5-1
5.2	Wastewater Treatment	5-1
	5.2.1 Membrane Bioreactors	5-3
	5.2.2 Facility Design	5-6
	5.2.3 Facilities Layout	5-15
	5.2.4 MBR Capital Equipment Cost	5-15
5.3	Recycled Water.....	5-16
	5.3.1 Reverse Osmosis Treatment System	5-16
	5.3.2 Recycled Water Storage Tank.....	5-16
	5.3.3 Recycled Water Pump Station.....	5-17

- 5.3.4 Onsite Water Reuse Facilities 5-19
- 5.4 Effluent Disposal 5-19
- 5.5 Water Balance 5-20
- 6.0 Conclusions 6-1**
- 6.1 Water Supply 6-3
- 6.2 Wastewater Treatment and Disposal 6-3
- 6.3 Preferred Site Alternative 6-4
- 7.0 References 7-1**

Figures

1-1	Site and Vicinity Map	1-2
1-2	Property and Parcel Boundary	1-3
1-3	Aerial View of Proposed Site	1-4
1-4	Proposed Site Layout for Alternative A, Phase I.....	1-6
1-5	Proposed Site Layout for Alternative A, Phase II	1-7
1-6	Proposed Site Layout for Alternative B, Phase I	1-8
1-7	Proposed Site Layout for Alternative B, Phase II	1-9
1-8	Proposed Site Layout for Alternative C.....	1-10
1-9	Proposed Site Layout for Alternative D	1-11
3-1	Existing Well Site Map	3-3
3-2	Water Treatment, Wastewater Treatment, and Disposal for Alternative A, Phase I.....	3-8
3-3	Water Treatment, Wastewater Treatment, and Disposal for Alternative A, Phase II	3-9
3-4	Water Treatment, Wastewater Treatment, and Disposal for Alternative B, Phase I	3-10
3-5	Water Treatment, Wastewater Treatment, and Disposal for Alternative B, Phase II.....	3-11
3-6	Water Treatment, Wastewater Treatment, and Disposal for Alternative C.....	3-12
3-7	Water Treatment, Wastewater Treatment, and Disposal for Alternative D	3-13
3-8	Preliminary Water Treatment Plant Layout.....	3-14
3-9	Preliminary Process Flow Diagram.....	3-15
3-10	Typical Water Storage Tank	3-18
5-1	MBR WWTP Process Flow Diagram	5-5
5-2	Typical Headworks Plan and Section	5-9
5-3	Typical Operations Building Floor Plan	5-13
5-4	Typical Recycled Water Storage Tank	5-18
6-1	Flow Diagram without Recycled Water Alternative A	6-6
6-2	Flow Diagram with Recycled Water Alternative A	6-7

Tables

1-1	Facility Area (ft ²) Estimates	1-5
2-1	Estimated Wastewater Flows for Site Layout Alternative A, Phase I and II	2-3
2-2	Estimated Wastewater Flows for Site Layout Alternative B, Phase I and II	2-4
2-3	Estimated Wastewater Flows for Site Layout Alternative C	2-5
2-4	Estimated Wastewater Flows for Site Layout Alternative D	2-6
2-5	Estimated Wastewater Flows (gpd)	2-7

2-6	Estimated Water Demands Without Recycled Water (gpd)	2-9
2-7	Breakdown in Typical Domestic Water Uses at Varying Facilities	2-11
2-8	Estimated Recycled Water Demands (gpd)	2-12
2-9	Estimated Water Demands with Recycled Water (gpd)	2-12
3-1	Recommended Long-Term Well Yields	3-2
3-2	Comparison of Average Day Water Demand With and Without Recycled Water (gpd)	3-4
3-3	Groundwater Sampling Water Chemistry Results	3-5
3-4	Recommended Iron and Manganese Water Treatment Plant Design Criteria	3-7
3-5	Comparison of Average Day Influent RO Water Demand With and Without Recycled Water (gpd)	3-16
3-6	Domestic Water Storage Requirements with Recycled Water (gallons)	3-17
5-1	Non-Economic Advantages and Disadvantages of the MBR	5-3
5-2	Design Wastewater Treatment Plant Flows (gpd)	5-6
5-3	Estimated Average Day Wastewater Loads (lbs/day).....	5-6
5-4	Unit Process Summary for the MBR WWTP for Alternatives A, B, C, and D	5-14
5-5	Capital Cost Estimates	5-15
5-6	Recycled Water Storage Tank Requirements (gallons)	5-17
5-7	Design Wastewater Disposal Flows with Recycled Water (gpd)	5-20
5-8	Water Balance and Wastewater Disposal Requirements	5-21
6-1	Summary of Demands and Flows	6-2
6-2	Capital Cost Estimates	6-3

Appendix

A	Full Tables 2-1 through 2-4, Estimated Wastewater Flows for Site Layout Alternatives A through D
B	Pumping Tests and Sustainability Analysis for Wells H1, M1, and M3, and Evaluation of Water Quality
C	Amador Water Agency – Consumer Confidence Report 2003
D	Results of Soil Profile and Mantle Tests, AEG, October 20, 2004
E	Water Balance Calculations

1.0 Introduction

HydroScience Engineers, Inc. (HSe) was retained by Analytical Environmental Services (AES) to prepare this Water and Wastewater Feasibility Study for four proposed site development alternatives for the Ione Band of Miwok Indians Casino and Hotel Project. This study will be used to support the Environmental Impact Statement (EIS) being prepared by AES for the project. The scope of the study includes site background and field investigations, an evaluation of facility requirements, and a preliminary design of onsite water and wastewater facilities.

This report is organized into the following sections:

- Projected Flows
- Water Supply and Treatment
- Regulatory Requirements
- Wastewater Treatment and Disposal
- Conclusions

1.1 Background

The proposed project is located on the southern border of the City of Plymouth, in Amador County, California and is bound on the west by State Highway 49. A project Vicinity and Location Map are provided in Figure 1-1. Figure 1-2 shows those parcels included within the project scope. A table is also provided on Figure 1-2 listing the Assessors Parcel Numbers (APN) and the size of those said parcels. The total project site is approximately 228.04-acres in size. An aerial view is shown in Figure 1-3.

1.2 Project Description

Four alternative designs are being considered for the site. Three of the alternatives include variations of a casino and hotel, and the fourth includes a retail center. The four alternatives are as follows:

- Alternative A “Preferred Alternative” – Phase I includes a casino with 2,000 slot machines, 40 table games, and restaurant/bar areas (Figure 1-4). Phase II will add a 250-room hotel and a 1,200 seat event center, as shown in Figure 1-5.
- Alternative B – Phase I includes a casino with 1,500 slot machines, 30 table games, and restaurant/bar areas (Figure 1-6). Phase II will add a 250-room hotel and a 1,200 seat event center, as shown in Figure 1-7.

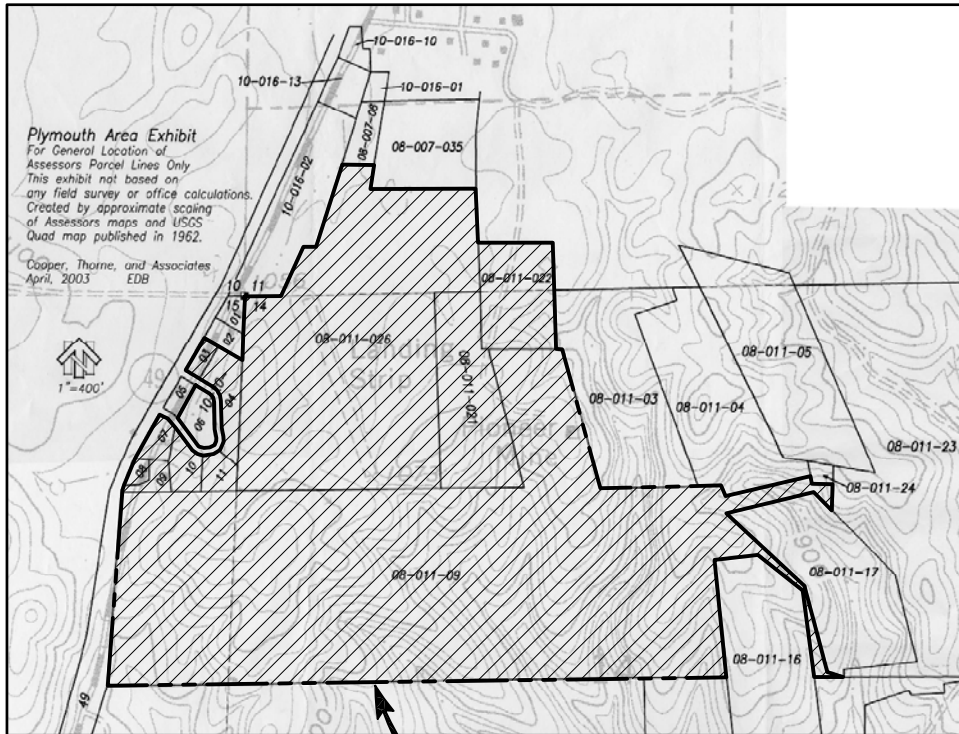

PROJECT SITE

PARCEL	APN	ACREAGE
1	08-011-009	137.78
2	08-011-021	12.12
3	08-011-022	7.86
4	08-011-026	60.0
5	10-020-003	0.64
6	10-020-004	2.68
7	10-020-006	1.65
8	10-020-007	1.19
9	10-020-008	0.53
10	10-020-009	0.81
11	10-020-010	1.56
12	10-020-011	1.22
TOTAL		228.04



Figure 1-2
Ione Casino and Hotel Feasibility Study
Property and Parcel Boundary

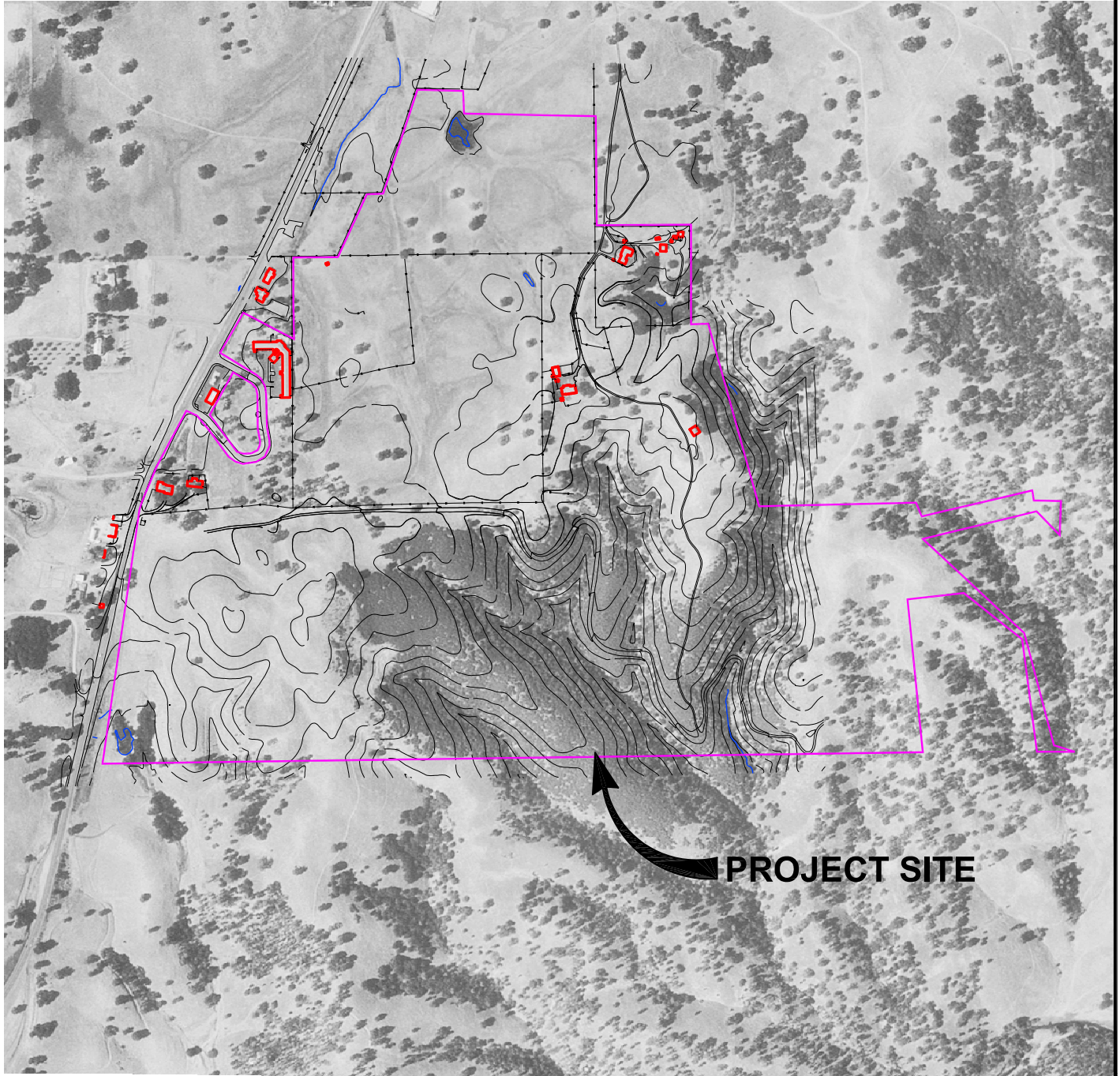
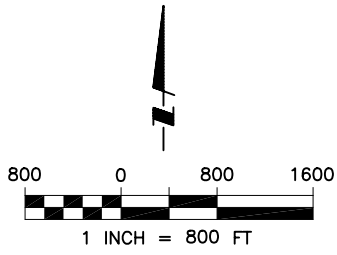

PROJECT SITE

S:\Common_projects\Rancheria\Vore Rancheria\W & HW Feasibility Study\AutoCAD\Figures\Fig 1-3.dwg DATE: 8/24/04



Figure 1-3
Ione Casino and Hotel Feasibility Study
Aerial View of Proposed Site

- Alternative C - A casino with 1,000 slot machines, 20 table games, and restaurant/bar areas as shown in Figure 1-8.
- Alternative D - A regional shopping center as shown in Figure 1-9.

Related facility area (square footage) estimates for each alternative are further summarized in Table 1-1.

TABLE 1-1
Facility Area (ft²) Estimates

Facility	Alternative			
	A	B	C	D
Casino				
Slot Machines	50,000	37,500	25,000	-
Table Games	15,000	11,250	7,500	-
Back of House Service and Support Areas	20,000	18,000	15,250	-
Food and Beverage	20,000	20,000	18,500	-
Public and Misc. Areas	15,000	14,000	13,000	-
Hotel	166,500	166,500	-	-
Event Center	30,000	30,000	-	-
Retail				
Anchor Stores	-	-	-	42,625
Inline Shops	-	-	-	80,625
Project Totals (ft²)	316,500	297,250	79,250	123,250

1.3 Objectives

The goal of this study is to identify and evaluate the water supply and wastewater service requirements for each of the project alternatives on a preliminary design level. Specific objectives of this study are to:

- Estimate water and wastewater flows for the site alternatives; and
- Evaluate facility requirements for acquiring water and wastewater service.

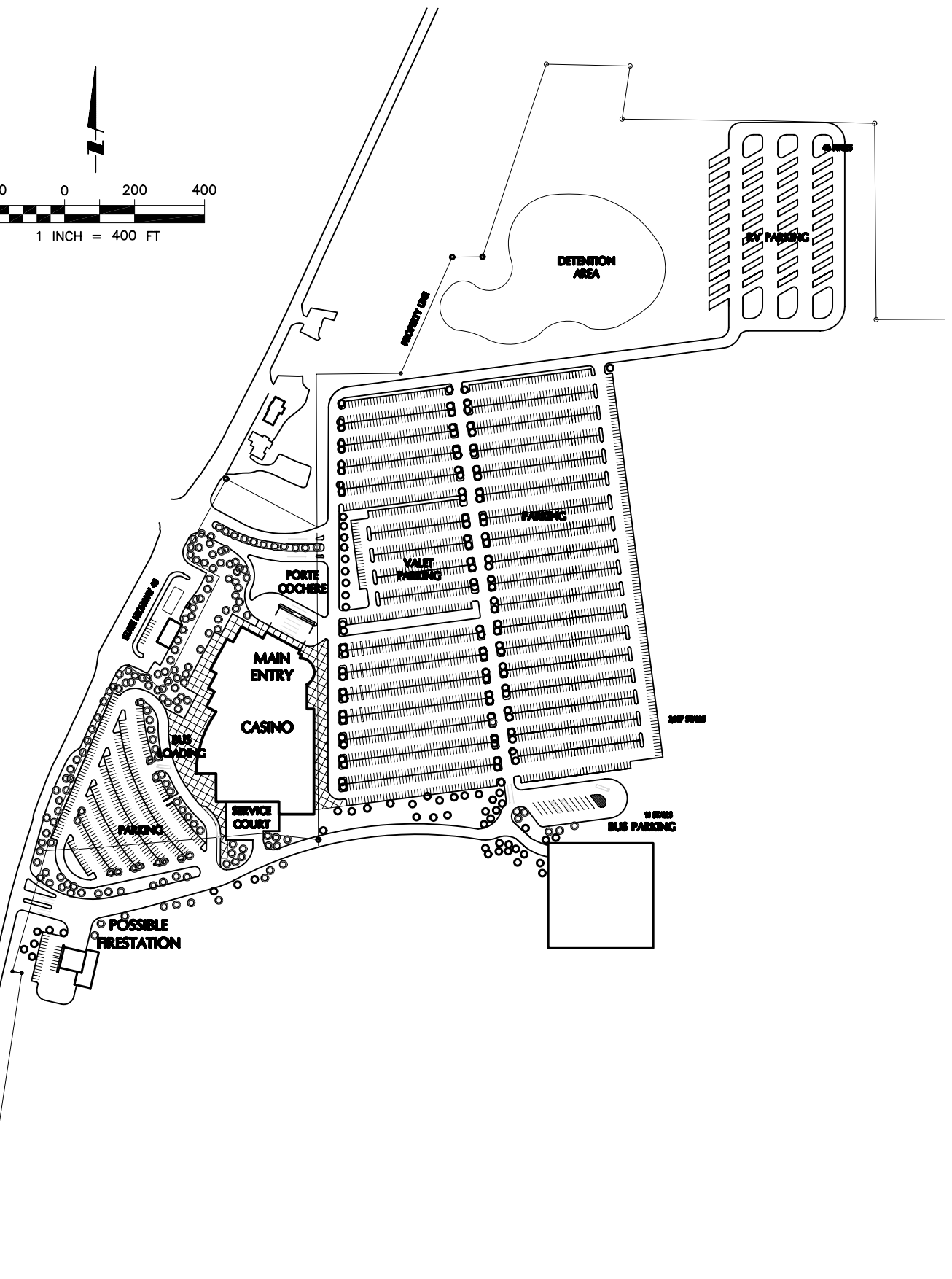
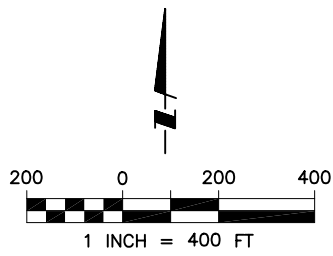

S:\common_projects\Rancheritos\Rancheritos\W & WW Feasibility Study\AutoCAD\Figures\Fig 1-4.dwg DATE:10/20/04



Figure 1-4
 Lone Casino and Hotel Feasibility Study
 Proposed Site Layout for Alternative A, Phase I

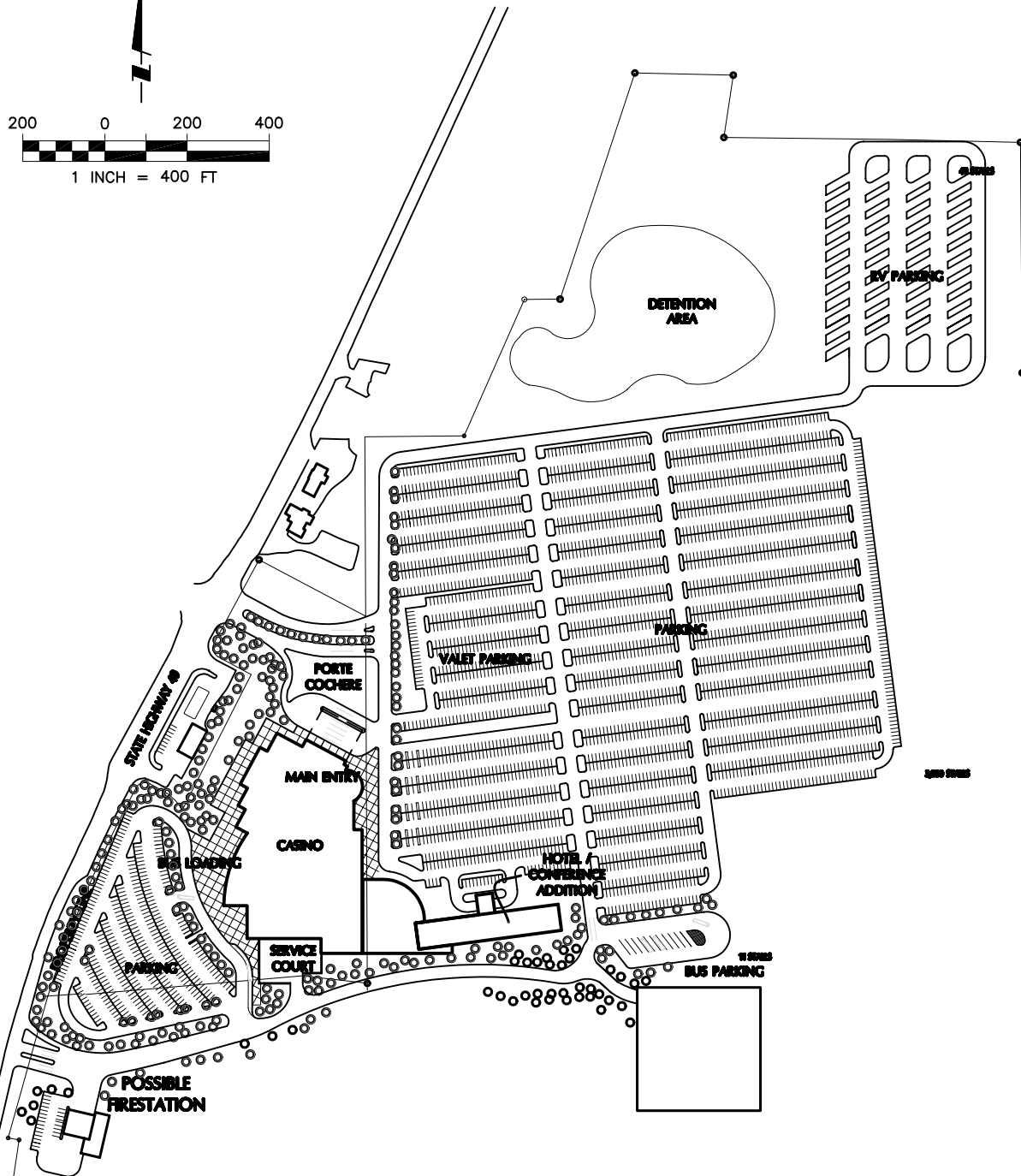
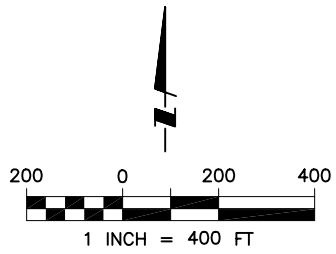

S:\common_projects\Rancheria\Nore Rancheria\W & WW Feasibility Study\AutoCAD\Figures\Fig 1-5.dwg DATE:10/20/04



Figure 1-5
 Lone Casino and Hotel Feasibility Study
 Proposed Site Layout for Alternative A, Phase II

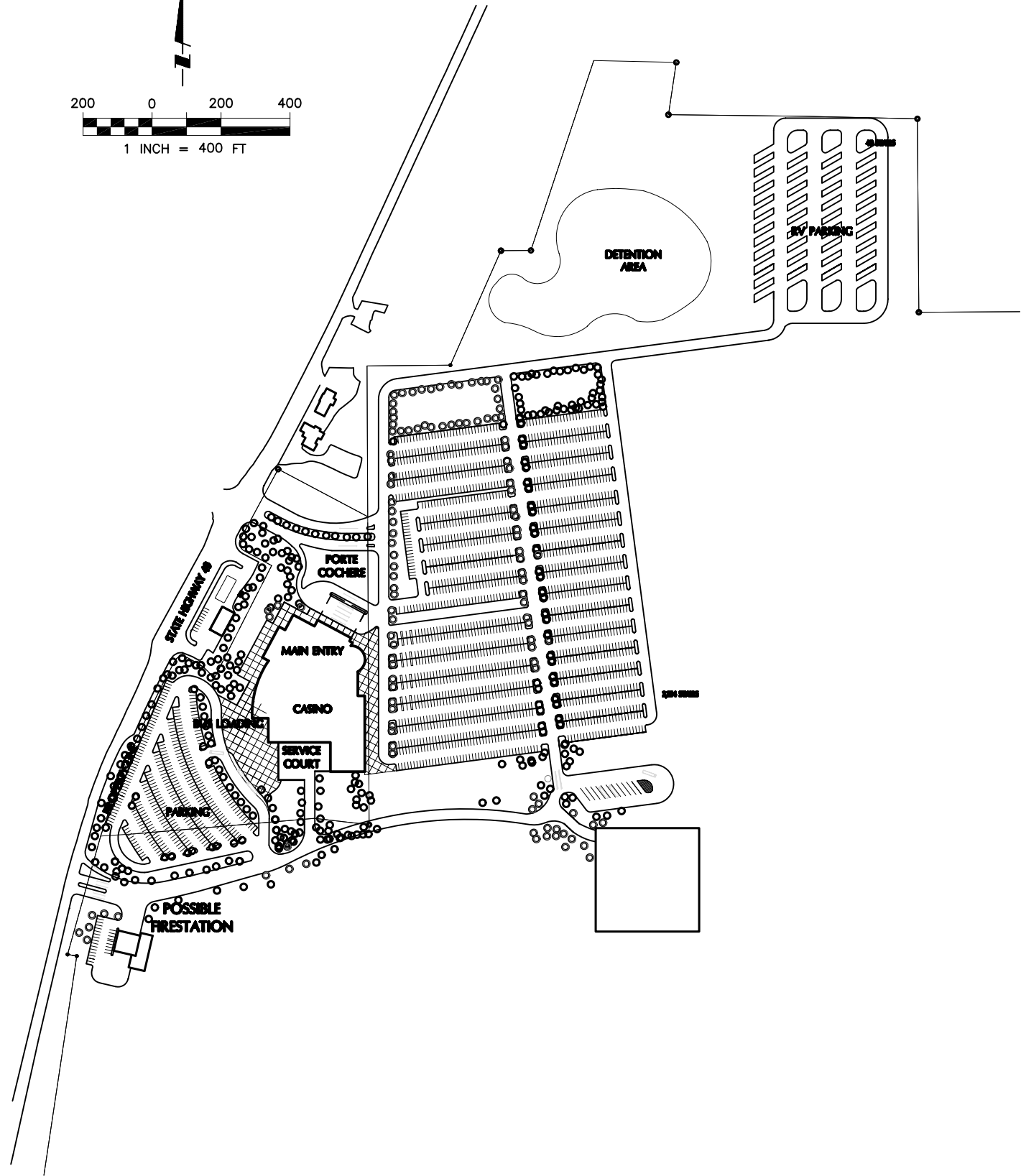
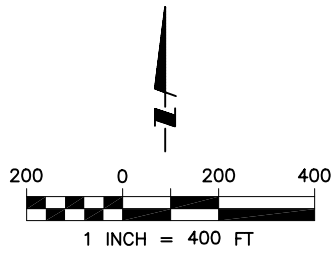

S:\common_projects\Rancheria\Vone_Rancheria\W & WW_Feasibility_Study\AutoCAD\Figures\Fig 1-6.dwg DATE:10/20/04



Figure 1-6
 Lone Casino and Hotel Feasibility Study
 Proposed Site Layout for Alternative B, Phase I

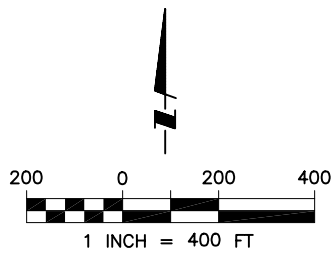

S:\common_projects\Rancheria\More Rancheria\W & WW Feasibility Study\AutoCAD\Figures\Fig 1-7.dwg DATE:10/20/04



Figure 1-7
 Lone Casino and Hotel Feasibility Study
 Proposed Site Layout for Alternative B, Phase II

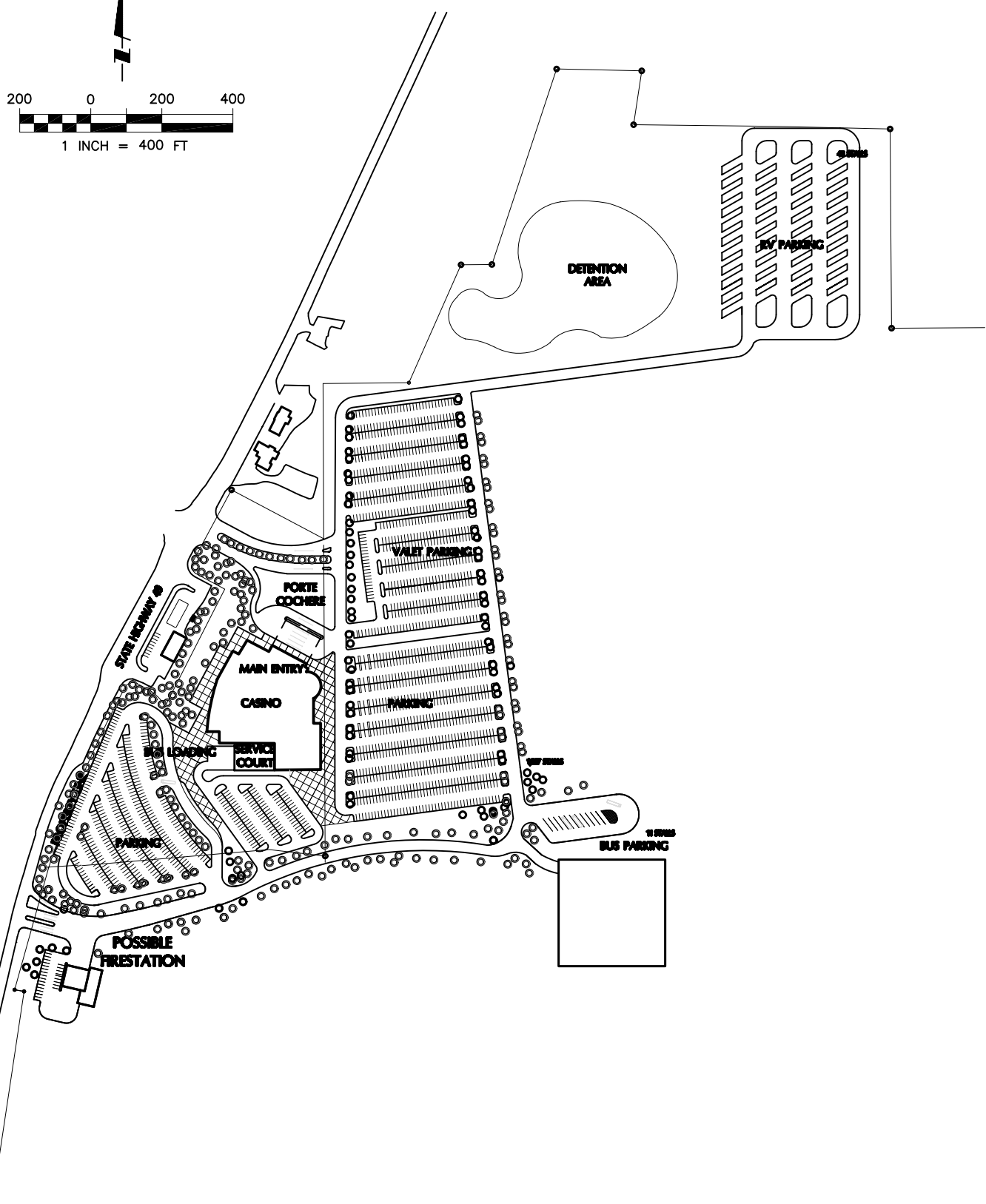
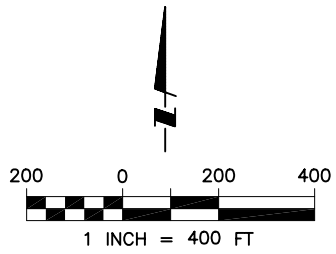

S:\common_projects\Rancheria\More Rancheria\W & WW Feasibility Study\AutoCAD\Figures\Fig 1-8.dwg DATE:10/20/04



Figure 1-8
 Lone Casino and Hotel Feasibility Study
 Proposed Site Layout for Alternative C

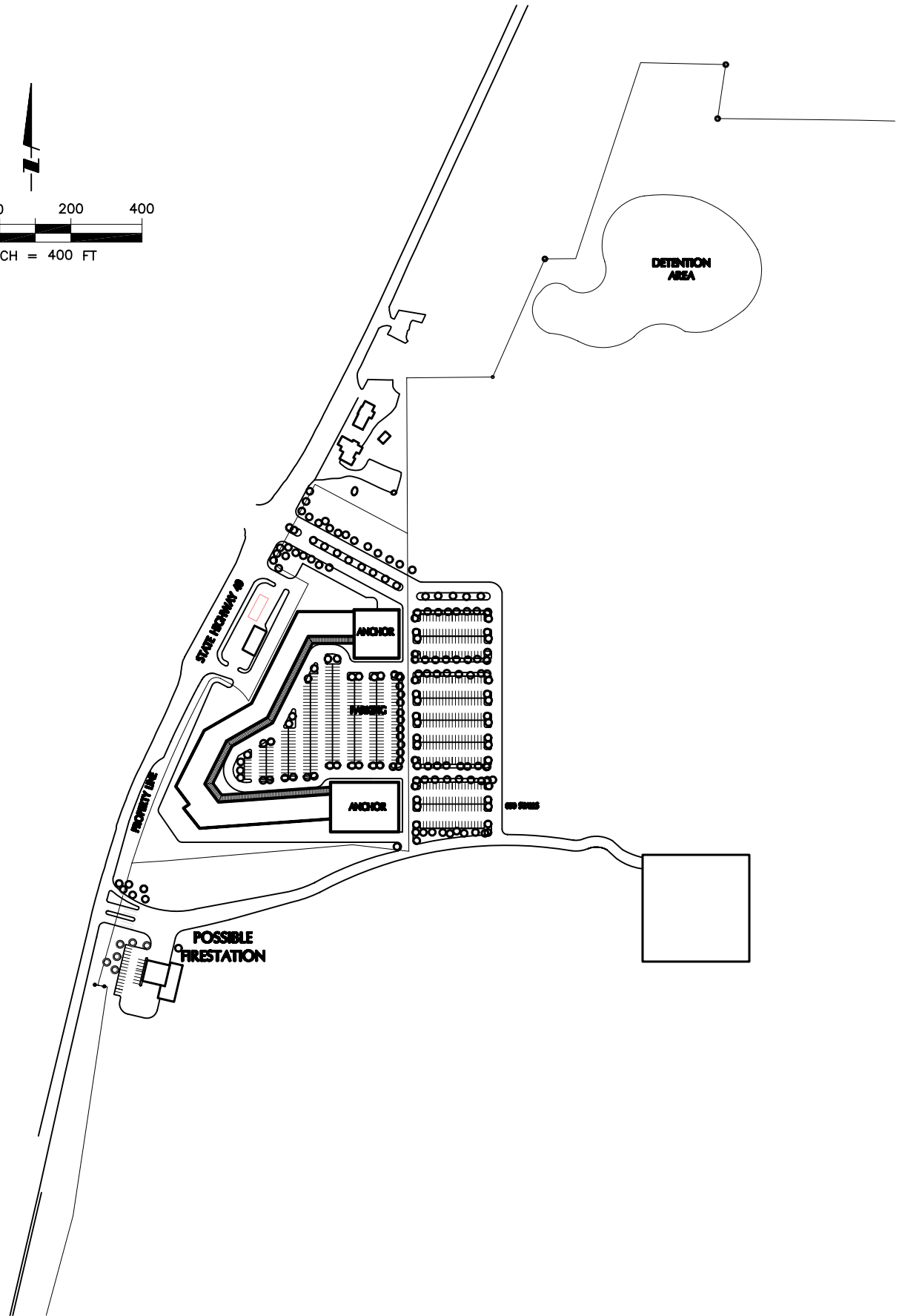
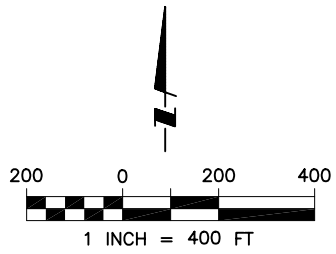

S:\common_projects\Rancheria\W & WW Feasibility Study\AutoCAD\Figures\Fig 1-9.dwg DATE:10/20/04



Figure 1-9
 Lone Casino and Hotel Feasibility Study
 Proposed Site Layout for Alternative D

2.0 Projected Flows

This section outlines the design criteria and general assumptions for estimating the wastewater production and water demand anticipated for the Project. The analysis begins with estimates on wastewater flow, since unit wastewater flow for the various services and customers is more readily available than water usage information. This data is subsequently used to back-calculate the corresponding water demand.

In addition to the water and wastewater flows, recycled water demand and its influence on the water demand and wastewater disposal requirements were also evaluated. Reclamation has the dual advantage of reducing the net potable water demand and the wastewater disposal requirements, since potable water demand traditionally needed for landscape irrigation and toilet flushing, for instance, can be satisfied with recycled water. At the same time, treated wastewater that would normally require disposal can instead be applied for beneficial reuse. The extent to which the reclamation program affects the potable water demand and wastewater disposal requirement is also summarized in this section.

2.1 Wastewater Flows

Facility programs are used to calculate the wastewater flows for the proposed site layout alternatives. The facility program provided for each site alternative describes what type of restaurants are proposed and the respective number of seats, the number of hotel rooms, slot machines, gaming tables, square footage of facility areas, and the like. From these descriptions and quantities, unit wastewater flows (gallons per day per unit) can be estimated. Tables 2-1 through 2-4 provide estimated wastewater flows for the four proposed site layout alternatives. Due to the size and complexity of the information used to generate the condensed results presented in Tables 2-1 through 2-4 refer to Appendix A for the complete versions of Tables 2-1 through 2-4.

Casinos differ from other business establishments in the hours that they are open, the type of services they provide, and occupancy rates. A casino is open 24-hours per day with times during each day when more guests are present than others. The peak times of the day vary slightly depending on the surrounding community but they typically have a pattern to the rate of occupancy. In this report the occupancy or use of the casino and hotel has been divided up into weekdays and weekends. Weekdays are from Monday through Friday when occupancy and flows are the lowest. Weekends are typically two days long, Saturday and Sunday.

Based on assumed flows from other similar casinos there are, during the above-mentioned weekdays and weekends, times of the day when the casino has a lower or higher occupancy rate. For example, during a typical weekday in the morning and early afternoon the casino has an occupancy rate of roughly 30 to 40 percent as compared to the late afternoon, evening, and night the casino may have a 60 to 70 percent occupancy rate.

For Tables 2-1 through 2-4 the estimated flows are based on a summation of flows for two 12-hour cycles, a 12-hour morning (a.m.) cycle and a 12-hour evening (p.m.) cycle. The rates of occupancy for the a.m. and p.m. cycles changes dramatically for weekdays and weekends.

An average estimated wastewater flow is calculated using the weekday and weekend flows. The average is calculated assuming five days of weekday plus two days of weekend flows. The average wastewater flow is useful in determining the design average day water demand and design wastewater disposal flow.

It is assumed that the casino and hotel heating and air conditioning system will include cooling towers. As shown in Tables 2-1 through 2-4, the assumed average day flow associated with the cooling towers is 15,000 gpd. For the Ione Rancheria project it is assumed that the average day blow down rate is also 15,000 gpd.

Although wastewater flows from a hotel vary throughout the day the hotel occupancy is not dependent on the same a.m. and p.m. rates as the casino. Therefore, the Tables 2-1 through 2-4 show the same hotel occupancy rates for the a.m. and p.m. periods.

Tables 2-1 through 2-4 show the term "I&I". This is an abbreviation for inflow and infiltration, which is typical in older gravity sewer collection systems or in areas of poor surface drainage and high groundwater. I&I is calculated as a percentage of the influent flow. For this project zero (0) percent is used, as this project will be a new construction and may contain a minimal length of PVC gravity sewer pipe and pressure force mains.

The tables' show a "Calculated Peaking Factor", which is for a reference check only, as the flows for weekday and weekend were calculated using estimated a.m. and p.m. occupancy rates for 12-hour cycles. The peaking factor is equal to the flow divided by the weekday flow.

TABLE 2-1
Estimated Wastewater Flows for Site Layout Alternative A, Phase I and II

	Square Footage (ft ²)	Quantity (each)	Units (each)	Frequency (uses/day)	Use Subtotal (units)	Flow/Unit (gpd/unit)	Flow (gpd)	Typical WEEKDAY Flows (gpd)	Typical WEEKEND Flows (gpd)	AVERAGE Day Flows ^a (gpd)
Casino										
Slots	50,000	2,000	seats	12	24,000	4	96,000	50,400	96,000	63,429
Tables (40 tables @ 7 seats per table)	15,000	280	seats	12	3,360	4	13,440	7,056	13,440	8,880
Employees		1,412	employees	3	4,236	13	55,068	22,027	34,418	25,567
Restaurants	20,000									
Buffet		250	seats	12	3,000	4	12,000	4,800	10,500	6,429
Restaurant #1 (Specialty)		100	seats	10	1,000	10	10,000	4,000	8,750	5,357
Coffee Bar		10	seats	12	120	3	360	144	315	193
Sports Bar		50	seats	12	600	3	1,800	720	1,575	964
Public & Miscellaneous Areas	15,000					0.0	0	0	0	0
Back of House (refer to employees)	20,000					0.2	4,000	1,600	2,500	1,857
Cooling Towers (Average Estimated Waste Flow)		1	LS				20,000	15,000	15,000	15,000
Parking		3,039	spaces			0.0	0	0	0	0
Hotel										
Rooms	166,500	250	rooms	1	250	150	37,500	18,750	37,500	24,107
Event and Convention Center	30,000					0.2	6,000	2,400	3,750	2,786
Subtotal	316,500									
Subtotal Daily Flows								126,897	223,748	154,569
I&I								0	0	0
Daily Flows								126,897	223,748	154,569
Calculated Peaking Factor								1.0	1.76	1.22

^a 5/7 * weekday + 2/7 * weekend day
Peaking factors are back-calculated as a reference check only and are not used to calculate flows.

TABLE 2-2
Estimated Wastewater Flows for Site Layout Alternative B, Phase I and II

	Square Footage (ft ²)	Quantity (each)	Units (each)	Frequency (uses/day)	Use Subtotal (units)	Flow/Unit (gpd/unit)	Flow (gpd)	Typical WEEKDAY Flows (gpd)	Typical WEEKEND Flows (gpd)	AVERAGE Day Flows ^a (gpd)
Casino										
Slots	37,500	1,500	seats	12	18,000	4	72,000	37,800	72,000	47,571
Tables (40 tables @ 7 seats per table)	11,250	280	seats	12	3,360	4	13,440	7,056	13,440	8,880
Employees		1,230	employees	3	3,390	13	47,970	19,188	29,981	22,272
Restaurants	20,000									
Buffet		250	seats	12	3,000	4	12,000	4,800	10,500	6,429
Restaurant #1 (Specialty)		100	seats	10	1,000	10	10,000	4,000	8,750	5,357
Coffee Bar		10	seats	12	120	3	360	144	315	193
Sports Bar		50	seats	12	600	3	1,800	720	1,575	964
Public & Miscellaneous Areas	14,000					0.0	0	0	0	0
Back of House (refer to employees)	18,000					0.2	3,600	1,440	2,250	1,671
Cooling Towers (Average Estimated Waste Flow)		1	LS				20,000	15,000	15,000	15,000
Parking		3,001	spaces			0.0	0	0	0	0
Hotel										
Rooms	166,500	250	rooms	1	250	150	37,500	18,750	37,500	24,107
Event and Convention Center	30,000					0.2	6,000	2,400	3,750	2,786
Subtotal	297,250									
Subtotal Daily Flows								111,298	195,061	135,230
I&I								0	0	0
Daily Flows								111,298	195,061	135,230
Calculated Peaking Factor								1.0	1.75	1.22

^a 5/7 * weekday + 2/7 * weekend day
Peaking factors are back-calculated as a reference check only and are not used to calculate flows.

TABLE 2-3
Estimated Wastewater Flows for Site Layout Alternative C

	Square Footage (ft ²)	Quantity (each)	Units (each)	Frequency (uses/day)	Use Subtotal (units)	Flow/Unit (gpd/unit)	Flow (gpd)	Typical WEEKDAY Flows (gpd)	Typical WEEKEND Flows (gpd)	AVERAGE Day Flows ^a (gpd)
Casino										
Slots	25,000	1,000	seats	12	12,000	4	48,000	25,200	48,000	31,714
Tables (40 tables @ 7 seats per table)	7,500	140	seats	12	1,680	4	6,720	3,528	6,720	4,440
Employees		852	employees	3	2,556	13	33,228	13,291	20,768	15,427
Restaurants	18,500									
Buffet		250	seats	12	3,000	4	12,000	4,800	10,500	6,429
Restaurant #1 (Specialty)		0	seats	10	0	10	0	0	0	0
Coffee Bar		0	seats	12	0	3	0	0	0	0
Sports Bar		50	seats	12	600	3	1,800	720	1,575	964
Public & Miscellaneous Areas	13,000					0.0	0	0	0	0
Back of House (refer to employees)	15,250					0.2	3,050	1,220	1,906	1,416
Cooling Towers (Average Estimated Waste Flow)		1	LS				20,000	15,000	15,000	15,000
Parking		1,579	spaces			0.0	0	0	0	0
Hotel										
Rooms	0	0	rooms	1	0	150	0	0	0	0
Event and Convention Center	0					0.2	0	0	0	0
Subtotal	79,250									
Subtotal Daily Flows								63,759	104,469	75,391
I&I								0	0	0
Daily Flows								63,759	104,469	75,391
Calculated Peaking Factor								1.0	1.64	1.18

^a 5/7 * weekday + 2/7 * weekend day
Peaking factors are back-calculated as a reference check only and are not used to calculate flows.

TABLE 2-4
Estimated Wastewater Flows for Site Layout Alternative D

	Square Footage (ft ²)	Quantity (each)	Units (each)	Frequency (uses/day)	Use Subtotal (units)	Flow/Unit (gpd/unit)	Flow (gpd)	Typical WEEKDAY Flows (gpd)	Typical WEEKEND Flows (gpd)	AVERAGE Day Flows ^a (gpd)
Retail										
Anchor Stores	42,625	0	seats			0.2	8,525	3,410	5,328	3,958
In-Line Shops	80,625	0	seats			0.2	16,125	6,450	10,078	7,487
Employees		720	employees	3	2,160	13	28,080	11,232	17,550	13,037
Restaurants										
Restaurant #1, Short Order		50	seats	10	500	4	2,000	800	1,750	1,071
Restaurant #2, Conventional Sit Down		50	seats	6	300	10	3,000	1,200	2,625	1,607
Coffee Bar		10	seats	12	120	3	360	144	315	193
Parking		650	spaces			2.0	1,300	520	813	604
Subtotal	123,250									
Subtotal Daily Flows								23,756	38,459	27,957
I & I								0	0	0
Daily Flows								23,756	38,459	27,957
Calculated Peaking Factor								1.0	1.62	1.18

^a 5/7 * weekday + 2/7 * weekend day
 Peaking factors are back-calculated as a reference check only and are not used to calculate flows.

A summary of estimated wastewater flows for the four site layout alternatives is provided in Table 2-5 below.

TABLE 2-5
Estimated Wastewater Flows (gpd)^b

Site Layout Alternative	A		B		C	D
	Phase I	Phase II	Phase I	Phase II		
Weekday Day	105,800	126,900	90,100	111,300	63,800	23,800
Weekend Day	192,500	233,700	153,800	195,100	104,500	38,500
Average Day ^a	130,600	154,600	108,300	135,200	75,400	28,000

^a 5/7 * weekday + 2/7 * weekend day

^b Wastewater flows rounded to the nearest 100.

2.2 Water Demands

There are many uses for domestic water in the proposed project. The water supplied or purveyed from the site will have the following uses.

Cooking	Bath Tubs	Water Features
Cleaning	Restrooms	Pools and Hot Tubs
Dishwashing	Sinks	Landscaping
Consumption	Janitorial	Cooling Towers
Showers	Laundry	

The domestic water demands are calculated from the estimated wastewater flows. It is assumed that there is a 5 percent loss in the domestic water flow as it becomes wastewater due to losses such as consumption, evaporation, and leakage.

There are three components to water usage in a cooling tower.

Evaporation – Water is evaporated over the tower to release heat and cool the HVAC system.

Blow Down – As water evaporates the impurities left behind become more concentrated. Therefore after a specified number of cycles, the water is wasted, otherwise known as blow down water.

Drift Losses – A percentage of the water is lost and unaccounted.

The total evaporation and drift loss is assumed to equal the assumed wasting rate or blow down of the cooling towers; 15,000-gpd.

No sizing of the cooling towers or water demands are provided at this time to better estimate the water demand and wastewater flows generated by the cooling towers. Therefore, for simplification it is assumed that this project mimics a similarly sized casino with a blow down rate almost equal to the evaporation and drift losses. The estimated total demand for the Preferred Site Layout Alternative A, Phase 1 and 2 is 30,000-gpd, (15,000-gpd evaporation & drift losses + 15,000-gpd blow down).

Water is also used for landscaping irrigation. For the Site Layout Alternatives A, B, and C it is assumed that a total of 2.0-acres of landscaping will be installed with an average water demand of 5,000-gpd/acre. A total water demand of 10,000-gpd is assumed for Alternatives A, B, and C. Site Layout Alternative D is assumed to have only 1.0-acre of landscaping and an assumed water demand of 5,000-gpd.

Table 2-6 shows estimated water demands as a function of estimated wastewater flows. Weekday, weekend, and average day flows are provided. It is assumed that 5 percent of water used is lost to consumption and other factors, and does not become part of the wastewater flow.

TABLE 2-6
Estimated Water Demands Without Recycled Water (gpd)

	A		B		C	D
	Phase I	Phase II	Phase I	Phase II		
Casino						
Slots	66,767	66,767	50,075	50,075	33,383	--
Tables	9,347	9,347	9,347	9,347	4,674	--
Employees	26,913	26,913	23,444	23,444	16,239	13,723
Restaurants						
Buffet	6,767	6,767	6,767	6,767	6,767	--
Specialty	5,639	5,639	5,639	5,639	0	--
Short Order	--	--	--	--	--	1,128
Conventional Sit Down	--	--	--	--	--	1,692
Coffee Bar	203	203	203	203	0	203
Sports Bar	1,015	1,015	1,015	1,015	1,015	--
Back of House (refer to employees)	0	0	0	0	0	--
Public & Miscellaneous Areas	1,955	1,955	1,759	1,759	1,491	--
Cooling Towers (Blow Down)	15,789	15,789	15,789	15,789	15,789	--
Cooling Towers (Evaporation & Drift) ^d	15,789	15,789	15,789	15,789	15,789	--
Parking	0	0	0	0	0	635
Hotel						
Rooms	0	25,376	0	25,376	--	--
Convention Center	0	2,932	0	2,932	--	--
Retail						
Anchor Stores	--	--	--	--	--	4,166
In Line Shops	--	--	--	--	--	7,881
Water Demands						
Weekday Day	126,500	148,600	109,800	132,200	82,100	1,200
Weekend Day	206,600	250,500	176,500	220,300	125,000	1,900
Average Day Demand ^a	150,200	178,500	129,800	158,100	95,100	29,400
Average Day Landscape Irrigation ^b	10,000	10,000	10,000	10,000	10,000	5,000
Recommended Water Supply^c	160,200	188,500	139,800	168,100	105,100	34,400

^a Water demands = wastewater flows / 0.95

^b Estimated at average daily demand of 5,000 gpd/acre landscaping. Type and acreage of landscaping assumed.

^c Recommended water supply = average day demand plus landscape irrigation.

^d Assume water demand for evaporation and drift losses are equal to blow down waste.

The recommended water supply is the average day demand plus landscape irrigation demand. It is assumed that the proposed water storage tank will provide enough storage to handle the higher weekend water demands. During weekday flows when the demand is less than the average day demand the water storage tank will fill to again provide weekend reserves. Therefore the average day demand is used to size the water supply recommended from the onsite well(s) and/or the offsite service connection(s).

2.3 Recycled Water

Recycled water in this report means wastewater that has been treated sufficiently to meet the California Department of Health Services' (DHS) comprehensive recycled water regulations that define treatment processes, water quality criteria, and treatment reliability requirements for public use of recycled water. These regulations are contained in Title 22, Division 4, Chapter 3 of the California Administrative Code, more commonly referred to as Title 22.

Approved by the State in December 2000, Title 22 prescribes recycled water criteria and divides them into several categories based upon the extent of public access or risk of exposure. In general, Title 22 regulations are more stringent for uses with high potential for public contact and less stringent for uses with low potential for public contact. Depending on the use, Title 22 establishes four levels of treatment required for recycled water: undisinfected secondary, undisinfected secondary-23, undisinfected secondary-2.2, and disinfected tertiary.

Disinfected Tertiary Recycled Water. This category of recycled water includes secondary effluent that has undergone tertiary treatment and has been disinfected to a level such that the median coliform bacteria in the water does not exceed 2.2 MPN per 100 mL. Title 22 defines the tertiary treatment process as wastewater that has been oxidized, coagulated, clarified, and filtered. The recycled water turbidity should not exceed 2 NTU on average, should not exceed 5 NTU more than five percent of the time during any 24-hour period, and should never exceed 10 NTU.

2.3.1 Design Criteria

To estimate the extent of the potable water applications that could be substituted with recycled water, average water usage for each facility was broken down according to the possible applications. These applications and their typical usage breakdowns are summarized in Table 2-7. All toilet flushing and landscaping can be dual-plumbed for use with recycled water. It is assumed that approximately 50 percent of the water demand for the cooling towers can be converted to recycled water use. The percent reduction in potable water demand use is then estimated on a basis of percent replacement by recycled water.

TABLE 2-7
Breakdown in Typical Domestic Water Uses at Varying Facilities

FACILITY	Toilet Flushing ^a	Bathing	Cooking, drinking	Laundry, dishes	Cooling Towers ^a	Landscape Irrigation ^a	WATER DEMAND REDUCTION USING RW
Casino	72% ^b	-	28%	-	-	-	72%
Events center	72% ^b	-	28%	-	-	-	72%
Restaurant	27%	-	53%	20%	-	-	27%
Hotel	27%	50%	8%	15%	-	-	27%
Retail	72% ^b	-	28%	-	-	-	72%
Cooling Towers	-	-	-	-	100%	-	50%
Landscape Irrigation						100%	100%

^a Can be converted to recycled water service.

^b Source: Irvine Ranch Water District
RW = Recycled Water

2.3.2 Recycled Water Demands

The use of recycled water at this casino and hotel for the use of flushing toilets, urinals, and the cooling towers would reduce the water demand. In similar facilities operating in California, such as Thunder Valley Casino and Cache Creek Casino & Hotel, they have historically recycled approximately 40% +/- of the wastewater flow for recycled water use. Therefore for the purpose of this estimate, it is assumed that 40 percent of the wastewater flow is recycled and used for such purposes. Table 2-8 shows the calculated recycled water demands as a factor of the estimated wastewater flows. Note that due to the fact landscape irrigation does not contribute to the wastewater flow, it has not been included as part of the recycled water demand in Table 2-8.

TABLE 2-8
Estimated Recycled Water Demands (gpd) ^c

Site Layout Alternative	A		B		C	D ^b
	Phase I	Phase II	Phase I	Phase II		
Week Day	42,300	50,800	36,000	44,500	25,500	n/a
Weekend Day	77,000	93,500	61,500	78,000	41,800	n/a
Average Day ^a	52,200	61,800	43,300	54,100	30,200	n/a

^a 5/7 * week day + 2/7 * weekend day

^b Alternative D does not include recycled water

^c Recycled water demand = 0.40 * wastewater flow

Does not include landscape irrigation demand

Recycled water demands rounded to the nearest 100 gpd.

2.4 Water Demands with Recycled Water

The domestic water demand can be reduced by the recycled water demand, as shown in Table 2-9. Landscaping water demands will be supplied by recycled water as an alternative means of wastewater effluent disposal thereby reducing the summer time disposal required.

TABLE 2-9
Estimated Water Demands with Recycled Water (gpd)

Site Layout Alternative	A		B		C	D ^c
	Phase I	Phase II	Phase I	Phase II		
Average Day Water Demand ^a	150,200	178,500	129,800	158,100	95,100	34,400
Recycled Water Demand	52,200	61,800	43,300	54,100	30,200	n/a
Recommended Domestic Water Supply ^b	98,000	116,700	86,500	104,000	64,900	34,400

^a 5/7 * week day + 2/7 * weekend day

^b Recommended supply = average day domestic water less recycled water.

^c Alternative D does not include recycled water and does include domestic supply of landscape irrigation.

Water demands rounded to the nearest 100 gpd.

Recycled water demand includes toilet flushing and process water.

3.0 Water Supply

This section describes components necessary to provide water supply service to the four project alternatives. It begins with a discussion of existing onsite facilities, source of supply, and then details the water quality. The final aspect is a preliminary evaluation of the water system requirements to deliver water to each of the four alternatives.

3.1 Existing Facilities

The proposed site contains eight parcels (APN: 10-200-003, 10-200-004, and 10-200-006 through 10-200-011) with existing water service from the City of Plymouth. The project site is also within the service boundary of the Amador Water Agency (AWA). In addition to AWA, there are several water supply wells located within a two mile radius of the project site.

3.1.1 City of Plymouth

The City of Plymouth serves the local population via storing and treating surface water from the Arroyo Ditch and treating groundwater from local wells. A water service moratorium was placed on the City in February 1990, by the California Department of Health Services (DHS), and limited future water service due to the lack of a reliable water supply. The City plans to utilize the Arroyo Ditch, local wells, and additional treated water from the AWA to provide the City with a reliable and redundant long-term supply alternative.

3.1.2 Amador Water Agency

Amador Water Agency (AWA) serves the areas of Jackson, Martell, Sutter Creek, Sutter Hill, Ione, Amador City, and Drytown, plus hundreds of customers between Lake Tabeaud and Sutter Hill. The primary source of water is the Mokelumne River, which is supplied from rainfall and snowmelt. This water is stored in Tiger Creek Afterbay and Lake Tabeaud and is treated prior to distribution.

3.2 Water Supply

3.2.1 Groundwater Wells

Based on Department of Water Resources (DWR) Well Completion Reports (DWR Well Logs) for all water supply wells within a two mile radius of the project site obtained by Applied Engineering and Geology, Inc. (AEG), it would appear that approximately 36 domestic water producing wells located within and near the City of Plymouth. These wells vary in depth from approximately 80 to 500 feet below ground surface (bgs), with static water levels ranging from approximately 14 to 200 feet bgs. The majority of the

wells are located on the western side of Plymouth. There are two wells located within the City of Plymouth that are reported to produce water at a rate greater than 200 gpm.

There are approximately 87 domestic water-producing wells in the vicinity of the project site. These wells vary in depth from approximately 100 to over 700 feet bgs. A large percentage of the wells produce greater than 50 gpm.

Most of the wells located within the immediate vicinity of the project site are shown to be low producing wells. With the exception of three wells, the wells are shown to produce less than 15 gpm, with four wells producing less than five gpm.

Four existing onsite wells (M1, M2, H1, and H2), an onsite cistern (CIS), and two off-site wells (M3, M4) were located during AEG's review. Their locations are shown in Figure 3-1. Of these wells, pumping tests were performed on M1, M3, and H1 by AEG. The pump testing methods included: step-drawdown tests, constant rate tests, constant yield/drawdown tests, and recovery tests. Table 3-1 presents AEG's recommended long-term well yields based on the pumping tests. A copy of the report prepared by AEG on the pumping tests and water quality analysis is included as Appendix B.

TABLE 3-1
Recommended Long-Term Well Yields ^{a b}

Well	Lower Limit	Upper Limit	Recommended Long-Term Well Yields
M1	8.5	12.1	10
M3	31.9	45.6	38
H1	28.5	40.7	35
Total Recommended Yield	68.9	98.4	83

^a All values shown in gallons per minute (gpm).

^b Source: Applied Engineering and Geology, Inc., *Pumping Test Report – Ione Rancheria* (August 2004).

3.2.2 Trucking

Potable water supply could be supplemented by purchasing water from an outside distributor and trucking the water to the project site. Costs associated with trucking in potable water are not provided in this report as they are dependent upon the volume of water required and the location of the distributor.

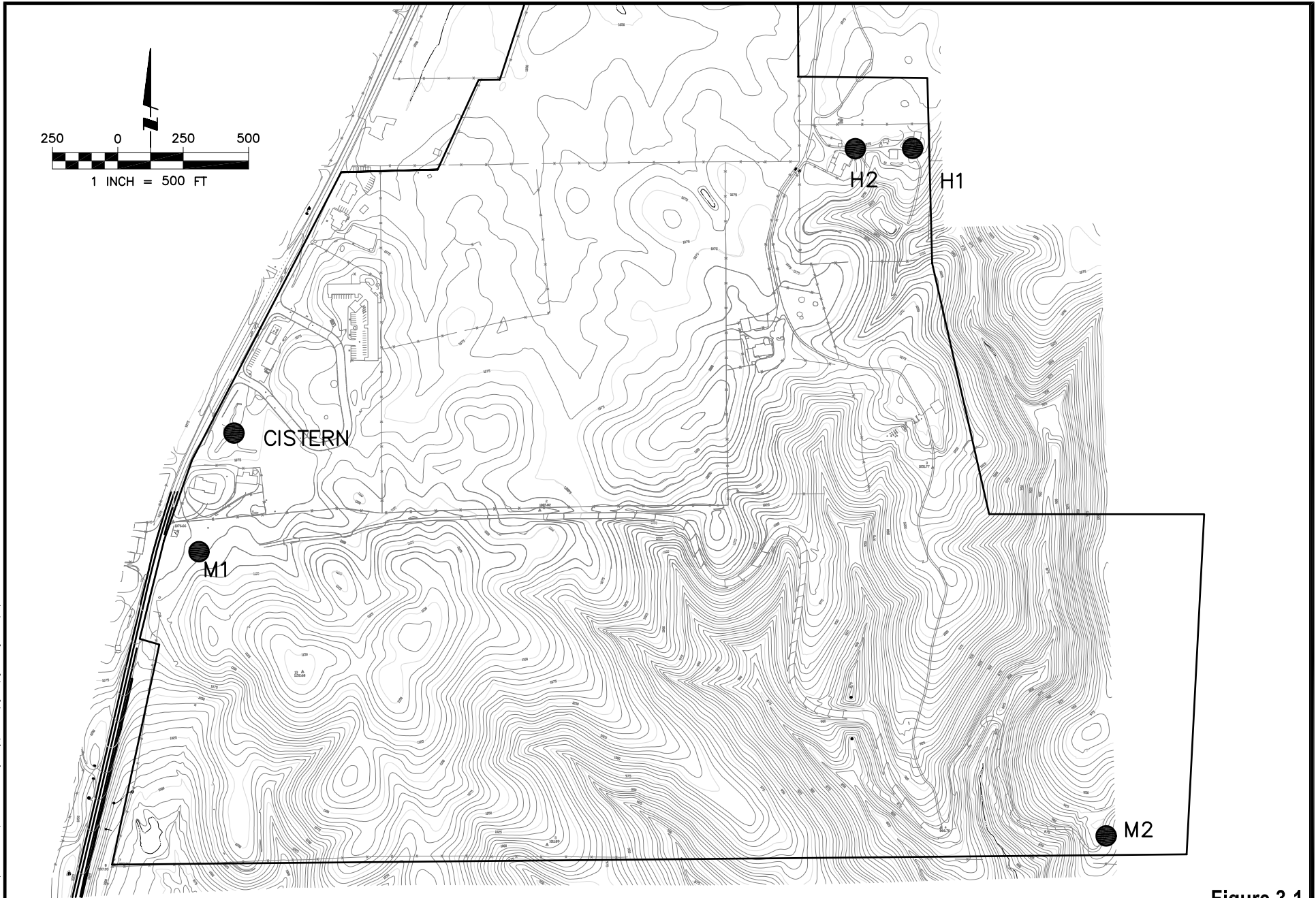

S:\Common_projects\Research\One Research\W & WW Feasibility Study\AutoCAD\Figures\Fig 3-1.dwg DATE:9/07/04

Figure 3-1
Ione Casino and Hotel Feasibility Study
Existing Well Site Map

3.3 Potable Water Demand

As discussed in Section 2, two potable water demands were developed: one as a total water demand and one with recycled water to supplement potable water consumption. Table 3-2 presents a comparison of the average daily water demand with and without the use of recycled water. The water demand presented is as a weighted average between the weekday and weekend flows, and includes landscaping water demand.

TABLE 3-2
Comparison of Average Day Water Demand with and without Recycled Water (gpd)

Site Layout Alternative	A		B		C	D ^c
	Phase I	Phase II	Phase I	Phase II		
Average day domestic water demand without recycled water ^a	160,200	188,500	139,800	168,100	105,100	34,400
Average day domestic water demand with recycled water ^b	98,000	116,700	86,500	104,000	64,900	34,400

^a Includes landscape irrigation

^b Recycled water includes landscape irrigation, toilet flushing, and process water.

^c Alternative D does not include recycled water

Water demands rounded to the nearest 100 gpd.

3.4 Water Quality

AWA distributes high quality water that meets federal and state requirements for safe drinking water. No additional treatment is required if obtaining water directly from one of the AWA water treatment plants. Water quality information on AWA drinking water is available from annual Consumer Confidence Reports published by the AWA. Appendix C contains a copy of the Consumer Confidence Report for the AWA.

Additional water quality information is available from the wells located on and within the vicinity of the project site. AEG collected water samples from each of the pumped wells (AEG, 2004). Table 3-3 summarizes the results from the water samples taken from the wells.

TABLE 3-3
Groundwater Sampling Water Chemistry Results ^a

Analyte	EPA Method	Crit. Quant.	M1	M3	H1
Arsenic (ug/L)	6020	5.0	< 5.0	< 5.0	< 5.0
Lead (ug/L)	6020	5.0	< 5.0	< 5.0	< 5.0
Selenium (ug/L)	6020	5.0	< 5.0	< 5.0	< 5.0
Thallium (ug/L)	6020	10	< 10	< 10	< 10
Antimony (ug/L)	6010B	50	< 50	< 50	< 50
Barium (ug/L)	6010B	20	50	< 20	39
Beryllium (ug/L)	6010B	5.0	< 5.0	< 5.0	< 5.0
Cadmium (ug/L)	6010B	10	< 10	< 10	< 10
Cobalt (ug/L)	6010B	20	< 20	< 20	< 20
Chromium (ug/L)	6010B	20	< 20	< 20	< 20
Copper (ug/L)	6010B	20	440	< 20	< 20
Molybdenum (ug/L)	6010B	20	< 20	< 20	< 20
Nickel (ug/L)	6010B	20	< 20	< 20	< 20
Silver (ug/L)	6010B	10	< 10	< 10	< 10
Vanadium (ug/L)	6010B	20	< 20	< 20	< 20
Zinc (ug/L)	6010B	20	60	< 20	< 20
Mercury (ug/L)	7470	0.20	< 0.20	< 0.20	< 0.20
Total Alkalinity (mg/L)	310.1	5.0	180	220	630
Bicarbonate as CaCO ₃ (mg/L)	310.1	5.0	180	220	630
Carbonate as CaCO ₃ (mg/L)	310.1	5.0	< 5.0	< 5.0	< 5.0
Hydroxide as CaCO ₃ (mg/L)	310.1	5.0	< 5.0	< 5.0	< 5.0
Chloride (mg/L)	300.0	0.50	7.0	12	26
Fluoride (mg/L)	300.0	0.10	0.34	0.21	0.24
Nitrate as NO ₃ (mg/L)	300.0	2.0	< 2.0	< 2.0	< 2.0
Sulfate as SO ₄ (mg/L)	300.0	2.5	2.2	60	230
Total Sulfides (mg/L) ^b	376.2	0.05	33	---	---
Total Sulfides (mg/L) ^c	376.2	0.05	< 0.05	---	---
MBAS (mg/L)	425.1	0.10	< 0.10	< 0.10	< 0.10

TABLE 3-3 (CONT)
Groundwater Sampling Water Chemistry Results ^a

Analyte	EPA Method	Crit. Quant.	M1	M3	H1
Specific Conductance (umhos/cm)	120.1	1	340	480	1,00
Calcium (mg/L)	200.7/2340B	1.0	32	60	170
Magnesium (mg/L)	200.7/2340B	1.0	18	32	110
Potassium (mg/L)	200.7/2340B	1.0	3.4	< 1.0	1.5
Sodium (mg/L)	200.7/2340B	1.0	23	11	30
Hardness as CaCO ₃ (mg/L)	200.7/2340B	1.0	160	280	860
pH (std. units)	150.1	--	8.00	6.90	7.20
Total Dissolved Solids (mg/L)	160.1	10	200	360	910

^a Results reported as micrograms per liter, unless otherwise noted.

^b Sample collected during pumping test.

^c Sample collected after pumping test was complete, but before water level in well had recovered.

3.5 Water Facilities

Due to the limited amount of available water supply in proximity to the project site, a multitude of supply sources are anticipated to be required to meet the various alternatives' water demands. The proposed sources of water for the project site include onsite wells and offsite wells, as well as trucking in water. The onsite and offsite wells would require further treatment prior to entering the potable water distribution system.

3.5.1 Water Treatment Plant

Based on groundwater quality identified in the previous section, it is anticipated that water supplied from any onsite or offsite wells will contain high levels of total dissolved solids (TDS), therefore it is recommended that a reverse osmosis (RO) treatment system be installed. It is also anticipated that water supplied from any onsite or offsite well will exceed the State secondary drinking water standards for iron and manganese. Thus, an onsite water treatment plant to remove iron and manganese would be required. It is recommended that the treatment plant utilize a manganese greensand pressure filtration process and remove iron and manganese to levels below 0.3 mg/L, and 0.05 mg/L, respectively. The backwash waste stream would be directed into a holding tank and settled water would be recycled back into the front of the water treatment plant at a rate not exceeding 10 percent of the plant's rated capacity. Iron and manganese sludge would be periodically discharged from the tank to the sewer system. The iron and manganese sludge will be filtered by the membrane bioreactor filters. Physical clogging or chemical damage to the filter membranes will not occur as a result from the iron and manganese sludge. The iron and manganese will become a small component of the sludge wasted from the wastewater treatment plant and disposed of to a local sanitary landfill. It is recommended that the plant be located near the proposed site for the wastewater treatment plant, as shown in Figure 3-2 to 3-7. A

typical layout of the iron and manganese plant is shown in Figure 3-8. A process flow diagram showing how water is treated within the treatment plant is shown in Figure 3-9.

The manganese filtration process consists of oxidation using a feed stream of sodium hypochlorite, and filtration through a manganese greensand filtration media. The function of the manganese greensand is to provide a catalyst to fully oxidize manganese, which may not be accomplished solely with a sodium hypochlorite oxidant. Potassium permanganate will be used to initially condition and prepare the media, and it may be used continuously or intermittently to aid in oxidation, if required. The feed of potassium permanganate will also be used to remove sulfides, control odor, and improve taste due to the sulfides. Sodium hypochlorite would be used to disinfect the water before distribution. A continuous monitoring chlorine residual analyzer will monitor chlorine residual at the end of the filters, before entering a water storage tank. Chlorine dosage control would be manual, with options for automatic pacing based on residual. The water treatment plant process facilities would be located within an enclosed building.

Significant features of the iron and manganese plant would include:

- PLC control system interlinked to a common water/wastewater SCADA system.
- Surface wash to reduce the possibility of “mudball” formation on the media surface.
- Fail-safe control valves that would fail in the filter-forward mode of operation.

Table 3-4 summarizes the recommended Iron and Manganese Water Treatment Plant design criteria.

TABLE 3-4
Recommended Iron and Manganese Water Treatment Plant Design Criteria

Parameter	Value
Process	Pressure Filtration
Media	Anthracite/Greensand
Number of Filters	1
Filter Loading Rate	3 gpm/sf
Filter Size	6 ft dia. X 72" high
Oxidant	Sodium Hypochlorite
Process Control	PLC/on with Service Well

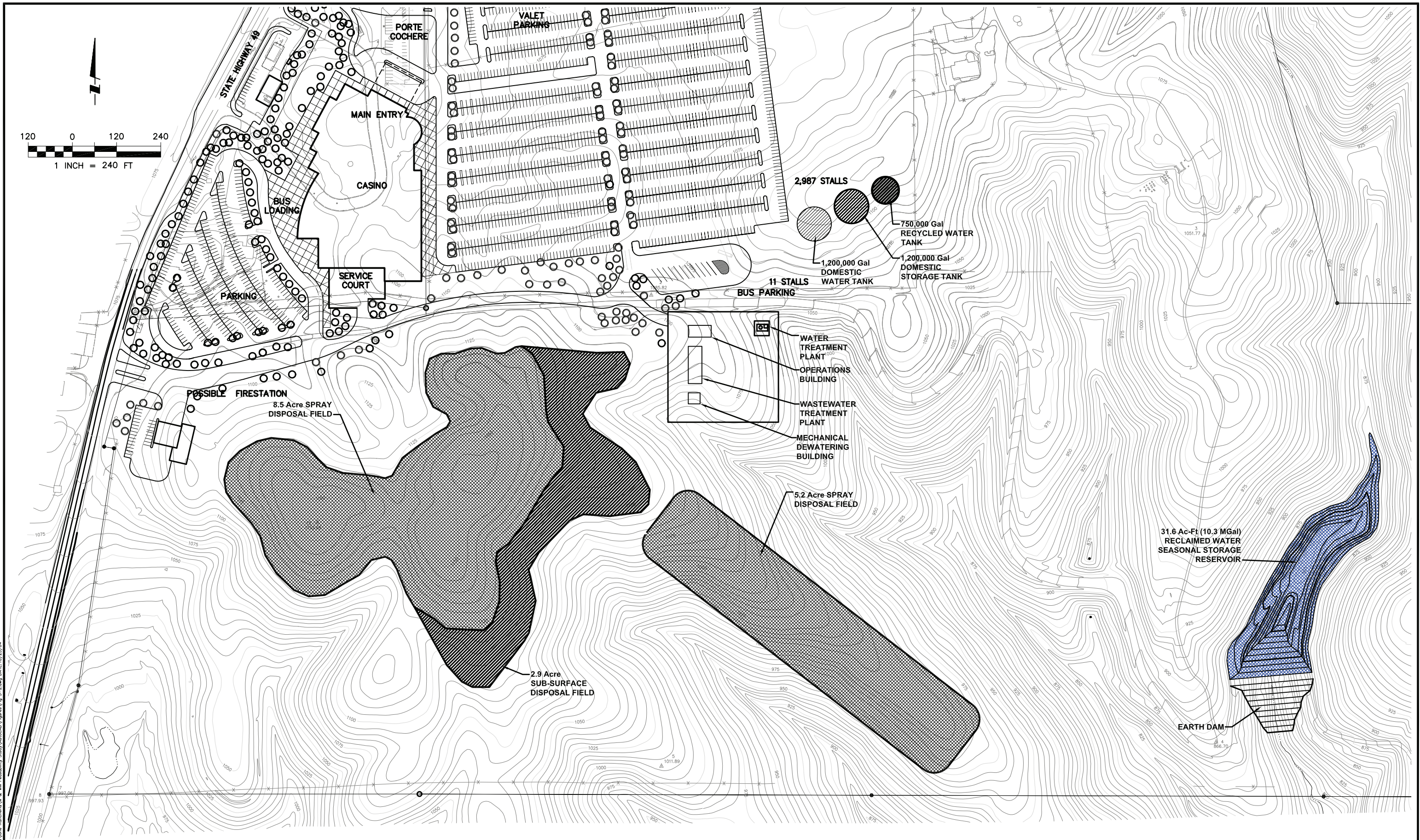

S:\Common\Projects\Bancroft\Bancroft\W & WW Feasibility Study\AutoCAD\Figures\Fig_3-2.dwg DATE:10/25/04

Figure 3-2
Ione Casino and Hotel Feasibility Study
Water Treatment, Wastewater Treatment, and Disposal Alternative A, Phase I

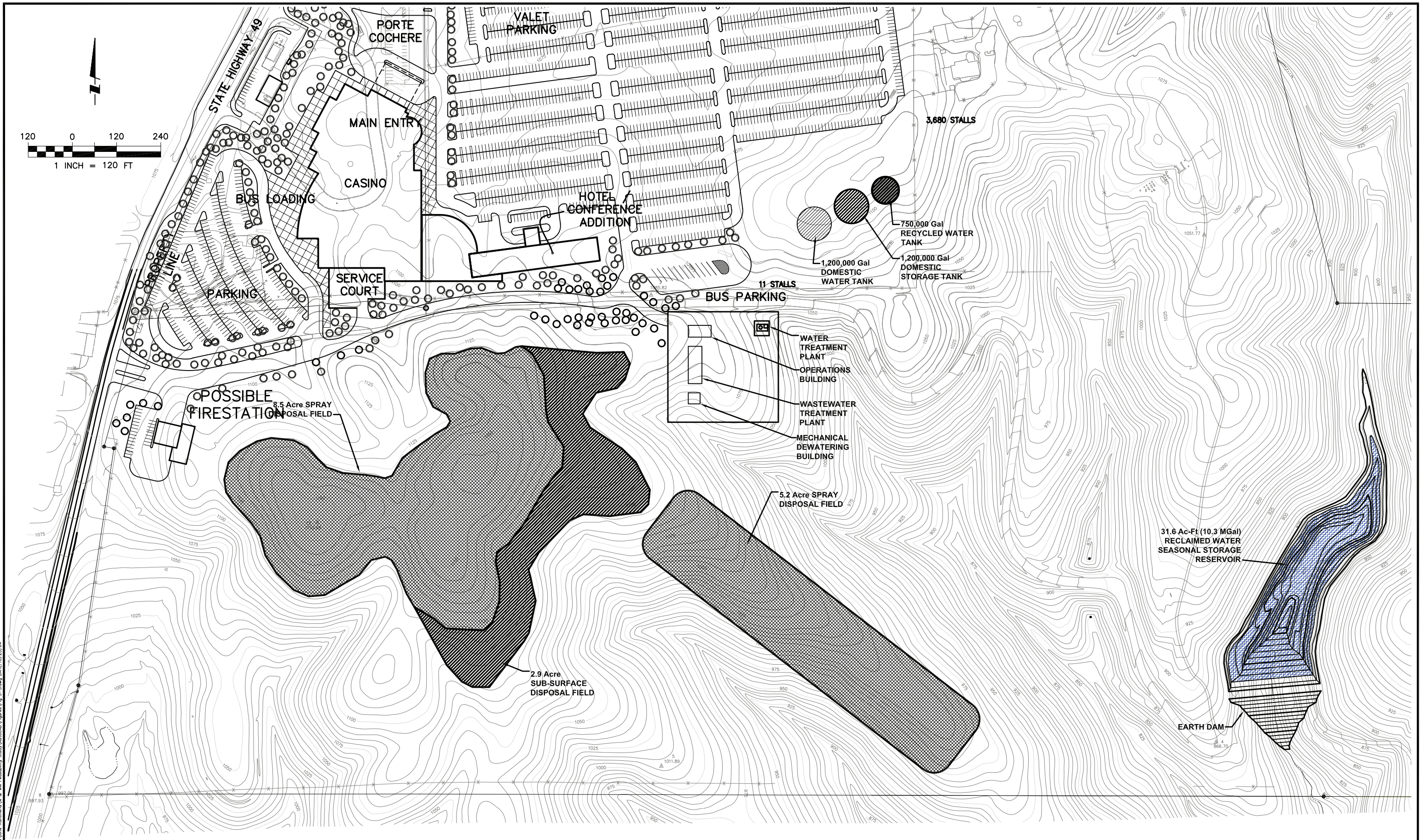

S:\Common\Projects\Yonkers\None_Ranchero\W & WW Feasibility Study\AutoCAD\Figures\Fig_3-3.dwg DATE:10/25/04

Figure 3-3
 Lone Casino and Hotel Feasibility Study
 Water Treatment, Wastewater Treatment, and Disposal Alternative A, Phase II

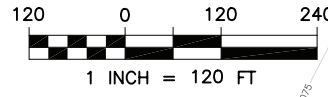
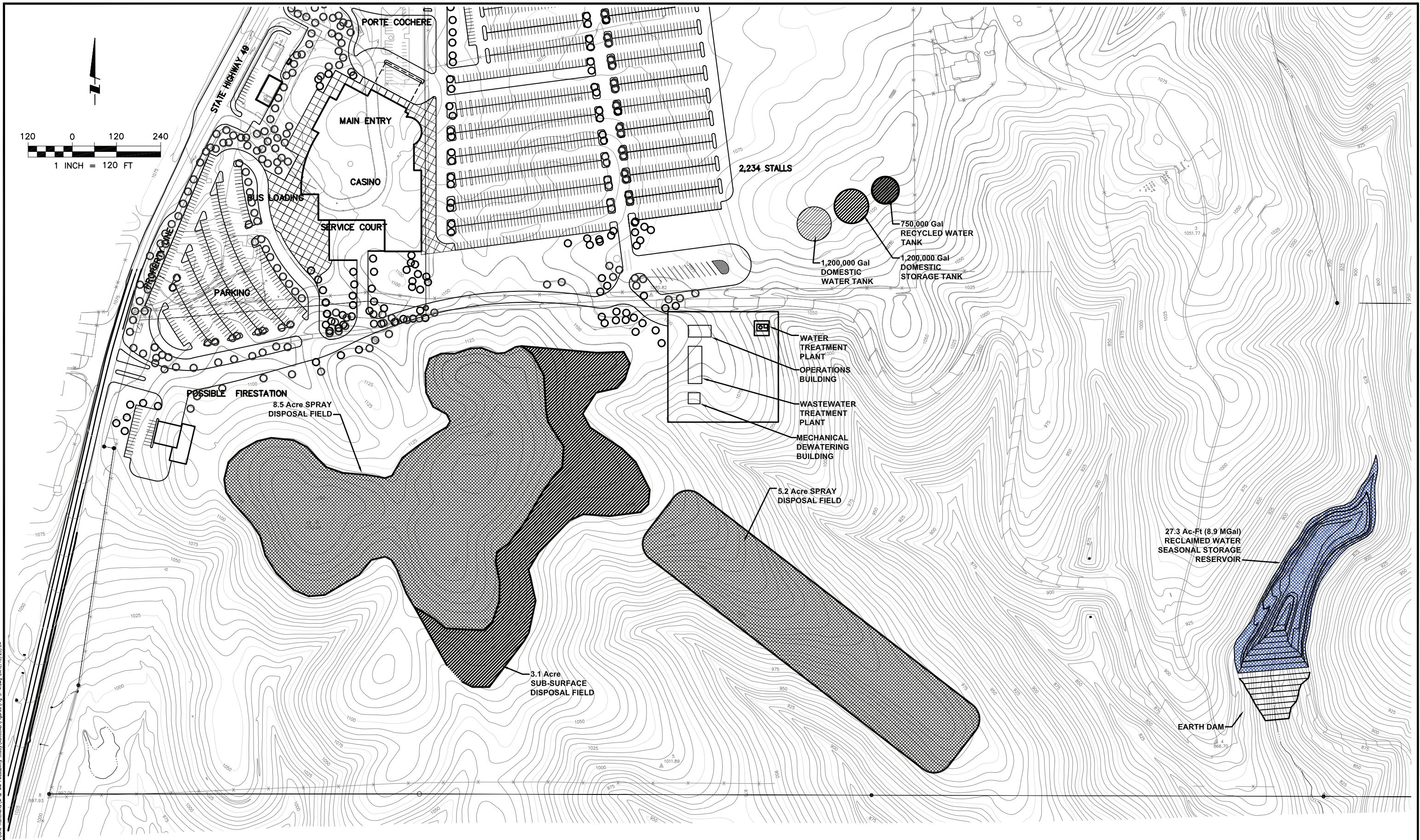

S:\Common\Projects\Bancroft\Bancroft\W & WW Feasibility Study\AutoCAD\Figures\Fig_3-4.dwg DATE:10/25/04

Figure 3-4
 Lone Casino and Hotel Feasibility Study
 Water Treatment, Wastewater Treatment, and Disposal Alternative B, Phase I

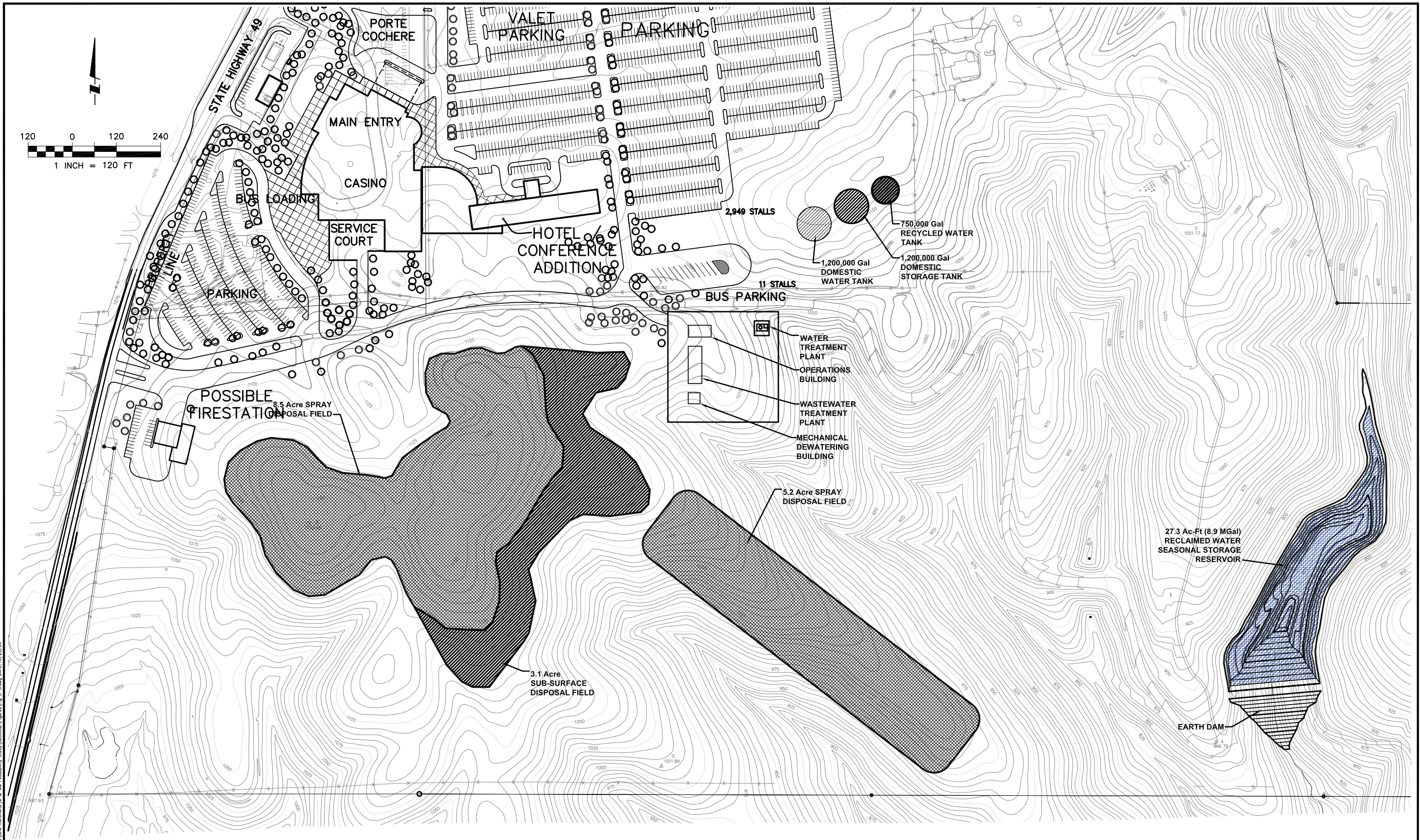

S:\Common\Projects\Bancroft\Bancroft\W & WW Feasibility Study\AutoCAD\Figures\Fig_3-5.dwg DATE:10/25/04

Figure 3-5
 Lone Casino and Hotel Feasibility Study
 Water Treatment, Wastewater Treatment, and Disposal Alternative B, Phase II

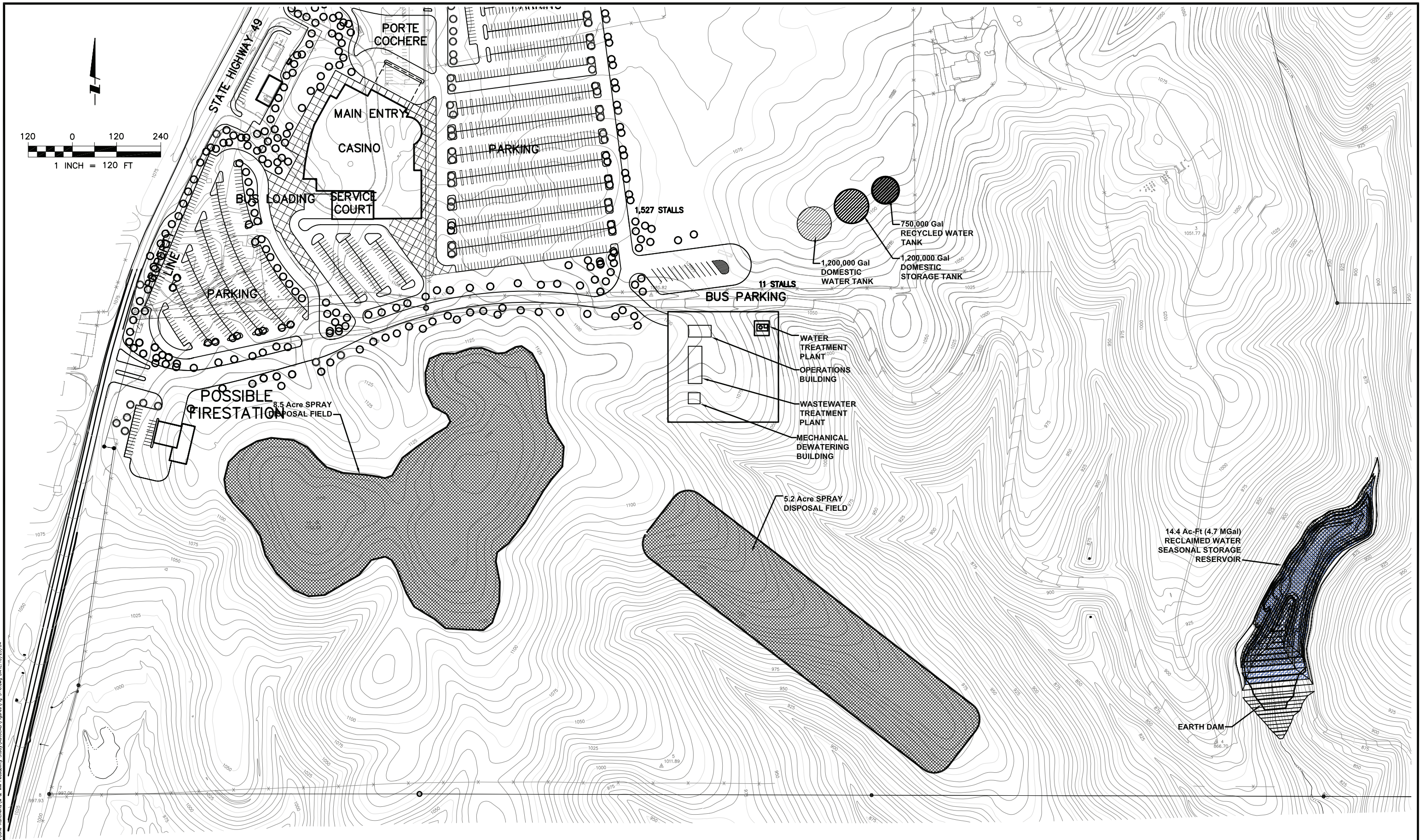

S:\Common\Projects\Bancroft\Bancroft\W & WW Feasibility Study\AutoCAD\Figures\Fig_3-6.dwg DATE:10/25/04

Figure 3-6
 Lone Casino and Hotel Feasibility Study
 Water Treatment, Wastewater Treatment, and Disposal Alternative C

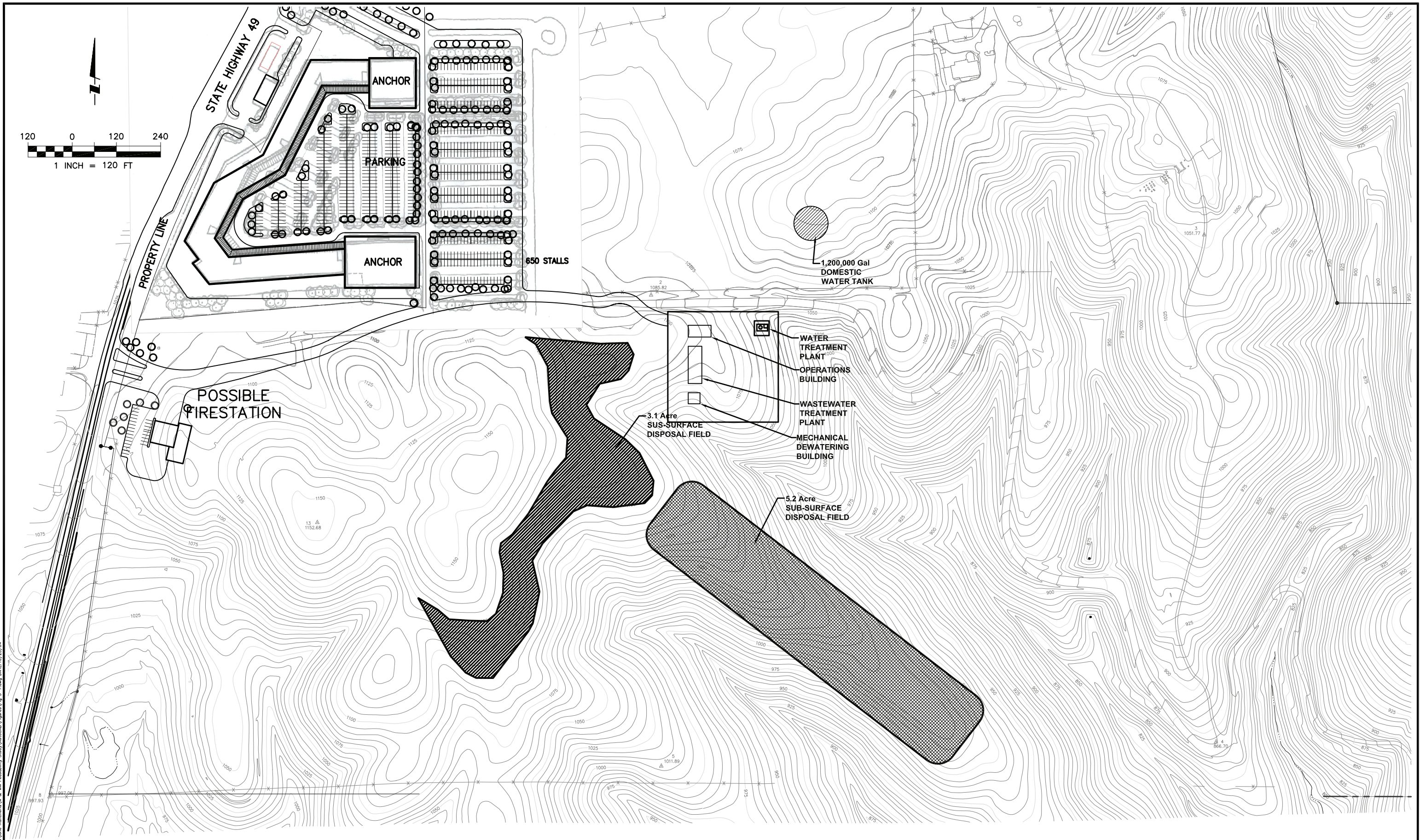

S:\Common\Projects\Yonkers\None_Rancheria\W & WW Feasibility Study\AutoCAD\Figures\Fig_3-7.dwg DATE:10/25/04

Figure 3-7
Lone Casino and Hotel Feasibility Study
Water Treatment, Wastewater Treatment, and Disposal Alternative D

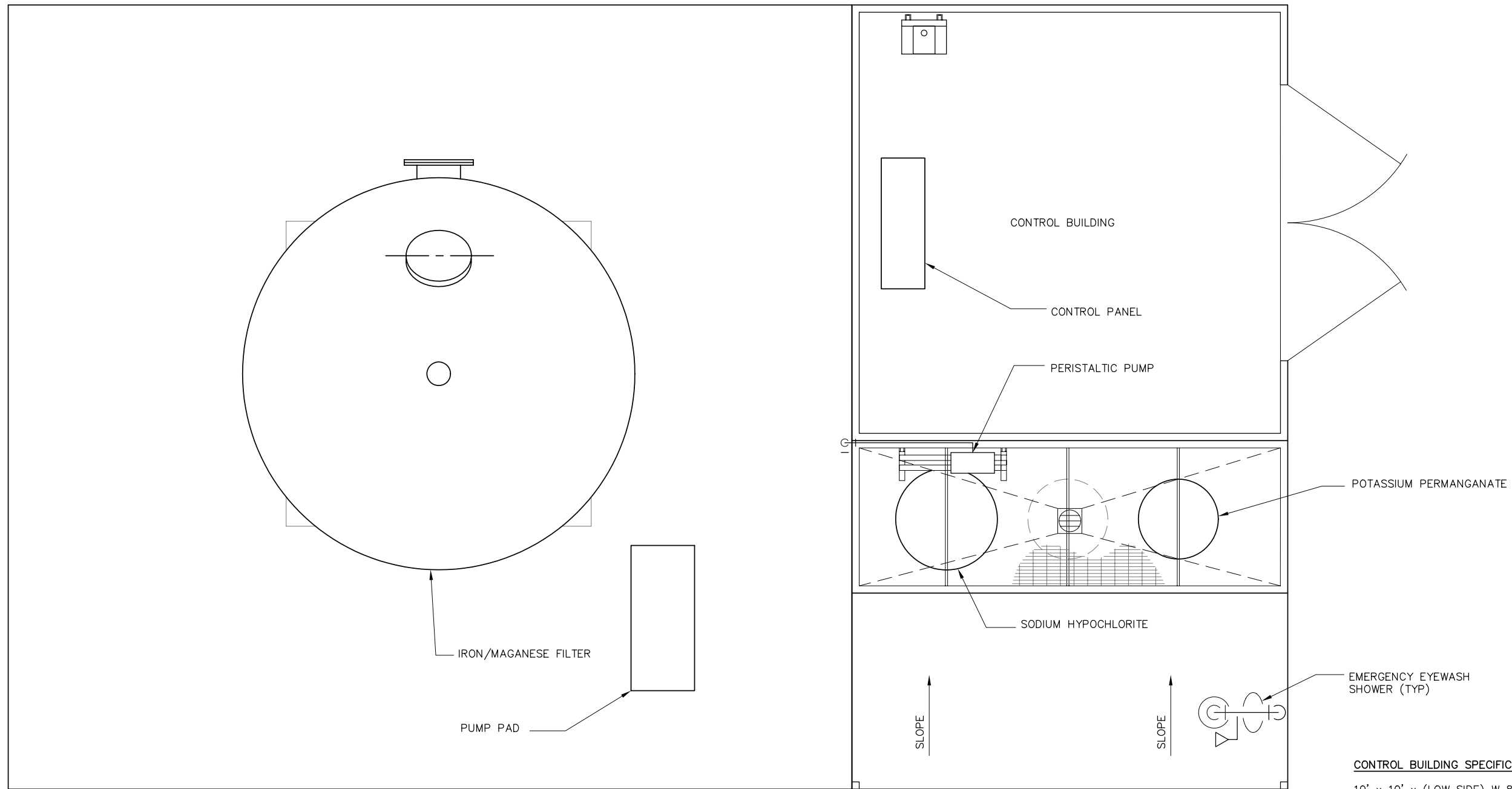

SITE PLAN
SCALE: 1/2" = 1'-0"

CONTROL BUILDING SPECIFICATIONS:

- 10' x 10' x (LOW SIDE) W 8' x 10' CANOPY – SHED STYLE 1:12 SLOPE
- FRAME: 2" x 2" x 120 STEEL TUBE
ALL WELDED WALL SECTIONS TO BE BOLTED IN FIELD
- ROOF/SIDING: McELROY "MULTI-RIB"
28 GA RIBBED METAL – PAINTED
- DOOR: 6' x 6'-8" DOUBLE SWING STEELCRAFT F-16
SERIES FRAME W/L18 SERIES DOOR W/POLYSTYRENE CORE
- LOCKSET: D SERIES W/ORBIT STYLE KNOB AND
ENTRANCE LOCK
- VENTS: 2 EACH 12" x 12" (NOMINAL)

S:\common\projects\roncheros\one_rancheros\ww_feasibility_study\autocad\figures\fig_3-8.dwg DATE: 8/23/04

PIPE SERVICE KEY

- BW BACKWASH
- D DRAIN
- FW FILTERED WATER
- KM POTASSIUM PERMANGANATE
- OF OVERFLOW
- RW RAW WATER
- SW SURFACE WASH
- SCLS SODIUM HYPOCHLORITE
- SAM SAMPLE

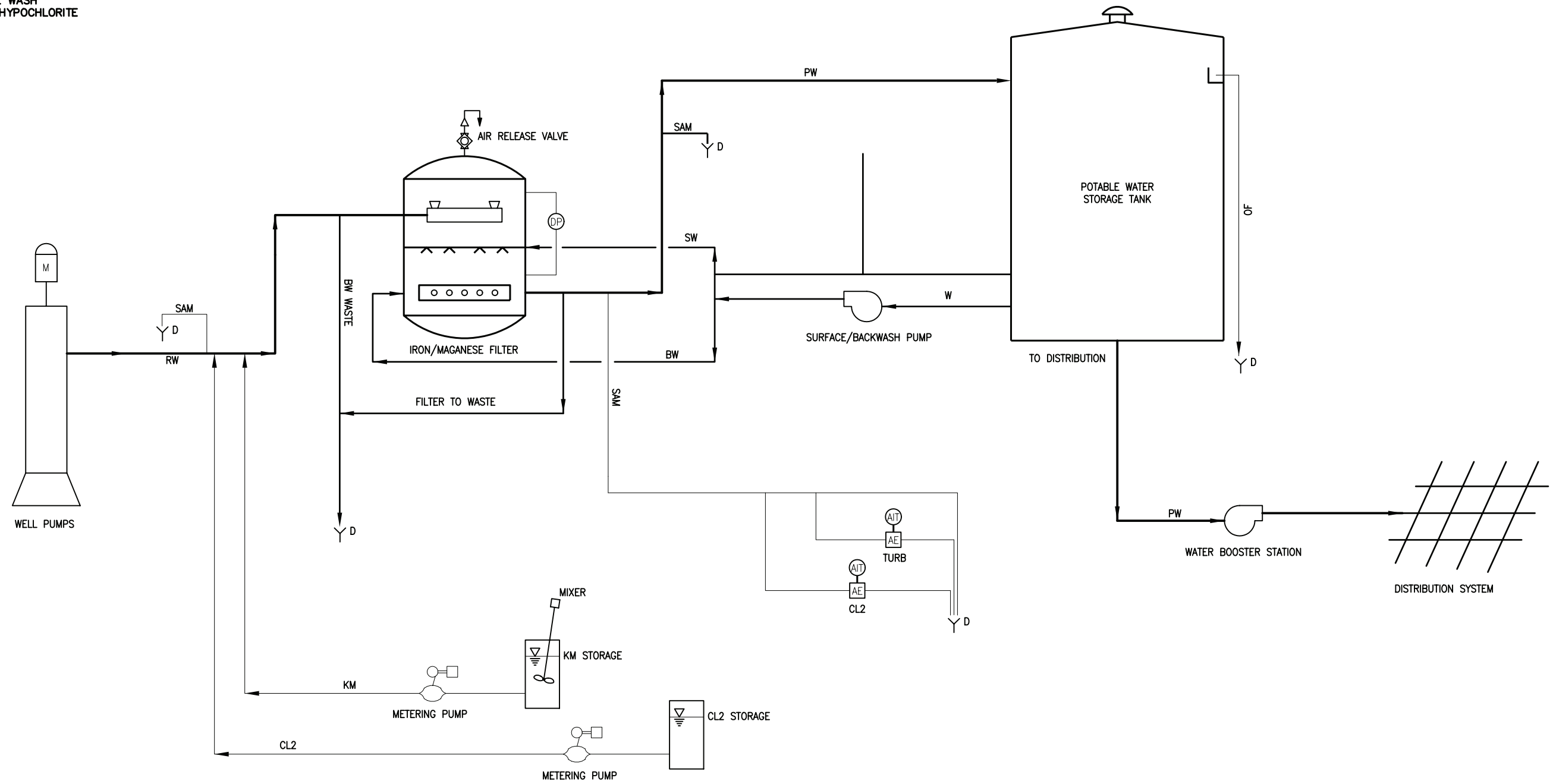

S:\common\projects\IoneCasino\IoneCasino\AutoCAD\Figures\Fig_3-9.dwg DATE: 9/07/04

Figure 3-9
Ione Casino and Hotel Feasibility Study
Preliminary Water Treatment Process Flow Diagram

The RO system removes dissolved minerals and salts from the water stream and produces water that is low in inorganic salts, organic matter, and bacteria. In the RO system, the influent stream passes across and through sheets of specialized semi-permeable membranes under high pressure. The membranes block the passage of dissolved minerals (with molecular weight over 100) while allowing the water to pass through. The water that passes through the membranes is called permeate or product. The mineral rich stream that the membranes reject is called reject or concentrate. The permeate water can be used as a direct feed to a distribution system, or stored in a reservoir or storage tank.

The reject stream would be then run through an additional RO unit to further concentrate the brine and minimize the water wasted. The brine would require disposing of. A similar system at Thunder Valley currently sends their brine to East Bay Municipal Utility District (EBMUD) for a fee based on the amount of brine. Table 3-5 presents the RO influent water demands that would be required to produce the finished water needed to satisfy the anticipated water demands (Table 2-6) from the various facilities for each Alternative.

TABLE 3-5
Comparison of Average Day Influent RO Water Demand with and without Recycled Water (gpd)

Site Layout Alternative	A		B		C	D ^c
	Phase I	Phase II	Phase I	Phase II		
Average day influent RO water demand without recycled water ^a	170,200	200,300	148,500	178,600	111,700	36,600
Average day influent RO water demand with recycled water ^b	108,000	128,500	95,200	114,500	71,500	36,600

^a Includes landscape irrigation. Based on an anticipated reject stream of 6.25% of the influent flow.

^b Recycled water includes landscape irrigation, toilet flushing, and process water.

^c Alternative D does not include recycled water

Water demands rounded to the nearest 100 gpd.

3.5.2 Water Storage Tank and Pump Station

A water storage tank would be constructed to store water produced by the water treatment plant. The actual required capacity of the tank is dependant on the project site's fire flow requirements and the selected project alternative. The anticipated capacity of the tank is summarized in Table 3-6 for the four alternatives. It should be noted the recommended capacity of the domestic water storage tank is affected by the use of recycled water to satisfy fire suppression could reduce the domestic water storage tank requirements.

TABLE 3-6
Domestic Water Storage Requirements with Recycled Water (gallons)

Site Layout Alternative	A	B	C	D
Average Day domestic water demand	200,000	179,000	112,000	37,000
Domestic water storage ^a	800,000	716,000	448,000	148,000
Fire suppression ^b	500,000	500,000	500,000	400,000
Domestic water storage tank capacity ^c	1,300,000	1,216,000	948,000	548,000
Recommended domestic water storage tank capacity ^d	1,300,000	1,250,000	1,000,000	600,000

^a 4.0 times the average day demand

^b Assumed storage required per local fire jurisdiction.

^c Domestic water storage plus fire suppression.

^d Rounded up to the nearest common tank size increment.

Water demands rounded up to the nearest 1,000 gal.

The water storage tank would be of welded steel construction meeting all American Water Works Association (AWWA) specifications for welded steel tanks. A typical section of a tank is shown in Figure 3-10. The tank would be cylindrical in shape. A shorter height and larger diameter tank will prove easier to mask from view using landscaping and natural features. The tank sizing would be based on standard pre-engineered tank dimensions, which are typically in 8-foot increments. It is possible that the tank would be partially or completely buried, but for the purpose of this analysis, it is assumed that the tank would be located at grade.

It is recommended that this tank be utilized as the supply and a pump station be utilized to maintain pressure in the distribution system. This potable water pump station will be required to convey water from the storage tank to the facilities requiring potable water and would be sized to handle both fire flow and domestic demands. The ultimate pumping capacity will be dependent on fire flow requirements and the selected project alternative.

It should be noted that two - 1 million gallon domestic water storage tanks are recommended as a part of this project for Alternatives A, B, and C.

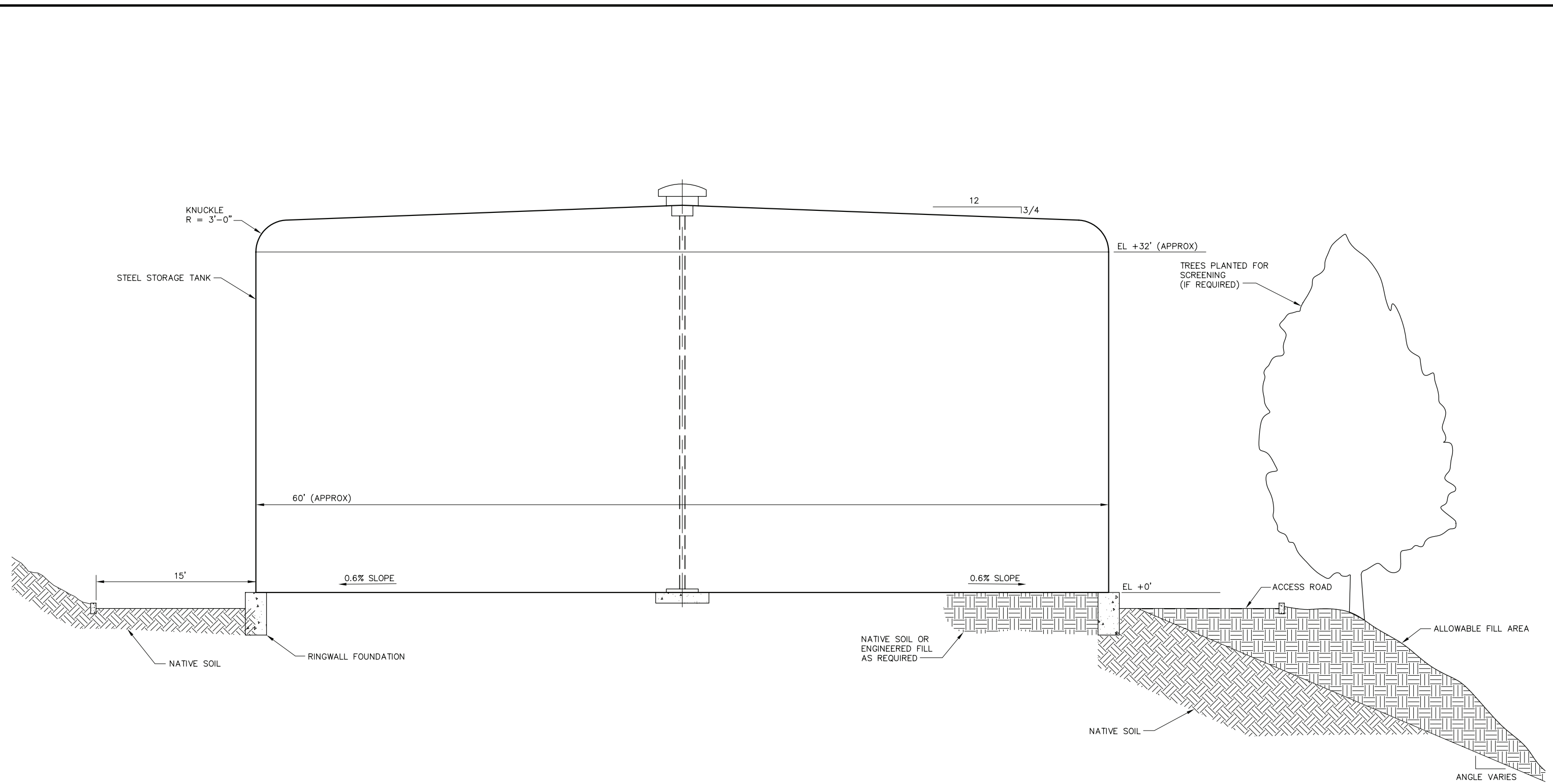

ELEVATION
NTS

S:\COMMON\PROJECTS\DRY_CREEK_RANCHERIA\DWGS\F104-2.DWG DATE:08/24/00

Figure 3-10
Ione Casino and Hotel Feasibility Study
Typical Water Storage Tank

4.0 Regulatory Requirements

4.1 Background

Wastewater treatment and disposal strategies are developed and evaluated in this report. Regulatory requirements for these strategies differ depending on the method of treatment and disposal. For example, the requirements for connection to the City of Plymouth sewage collection system will essentially be the annexation to the service area, payment of fees, and acquisition of encroachment permits. In contrast for the construction of an on-site wastewater treatment and disposal system, the County Department of Health would be typically the governing body issuing requirements and permits for the purpose of protecting the groundwater and preventing potential public health and nuisance problems. If out of their regulations, then the regional water quality control board (RWQCB) would be the governing body. However, since the proposed system is on Tribal lands, then the governing body would be the United States Environmental Protection Agency (USEPA).

4.2 Subsurface Disposal

Subsurface disposal permitting would likely be based on groundwater quality degradation criteria under recent USEPA guidelines. Under this permitting strategy, it would be necessary to perform a hydrogeological study to establish pollutant transport patterns in the nearest identifiable groundwater basin. An analysis would be required to determine the down-gradient environmental impacts to the beneficial users of the groundwater and the permit would likely contain mass-based discharge limitations.

Typical discharge prohibitions include:

- Discharge of wastes to surface waters or surface water drainage courses,
- Discharge of wastes to areas other than the designated treatment and disposal areas, and
- Bypass or overflow of untreated or partially treated waste.

Typical discharge specifications include:

- Objectionable odors originating from the WWTP shall not be perceivable beyond the boundary of the WWTP and disposal areas.
- Wastewater discharged to leachlines shall remain underground at all times.
- The distance between any unlined pond or leaching trench bottoms and the anticipated highest groundwater shall be greater than 6 inches, or such distance as necessary to provide compliance with local groundwater limitations.

- Operation of the WWTP shall be performed by wastewater treatment operators licensed by the State of California.
- Public contact with the wastewater shall be precluded through such means as fences and signs or acceptable alternatives.

4.3 Land Disposal

Land disposal, such as through the use of sprayfields, would likely be reviewed by the USEPA consistent with local Basin Plan Objectives. Typical requirements include tailwater and runoff control, possible installation of monitoring wells, and consideration of antidegradation provisions.

Typical discharge prohibitions include:

- The direct, point-source discharge of pollutants or wastes to surface waters or surface water drainage courses;
- Bypass around, or overflow from, the treatment plant and spray disposal area of untreated or partially treated waste; and
- Resurfacing of wastewater percolating from the spray disposal field.

Typical discharge specifications include:

- Wastewater spray drift from the WWTP or spray disposal field shall not migrate out of the plant's property boundaries.
- All tailwater and/or stormwater shall be collected and returned to the holding ponds at all times when wastewater is being applied to the spray disposal field.
- The discharger shall not irrigate with effluent 24 hours before precipitation, during periods of precipitation, and for 24 hours after wastewater application has ceased.
- The tailwater recapture system must be operated to capture all wastewater runoff, as well as any stormwater runoff that occurs within 24 hours of the last application of wastewater.
- The discharger shall cease spray irrigation of wastewater when winds exceed 30 mph.
- Public contact with wastewater shall be precluded through such means as fences, placards, and/or irrigation management practices (or other acceptable methods).
- Objectionable odors originating at this facility shall not be perceivable beyond the boundary of the WWTP and disposal areas.
- A controlled 100-foot buffer shall be maintained around the spray disposal field's wetted area created during wastewater application.

4.3.1 Surface Water Disposal

Surface water discharges would be issued by the USEPA in the form of a National Pollution Discharge Elimination System (NPDES) permit and in accordance with the RWQCB Basin Plan standards. Additionally, the NPDES permit would likely be subject

to the requirements of the California Toxics Rule (CTR). The USEPA has recently promulgated the CTR to bring the state in compliance with the Clean Water Act for priority toxic pollutants. The USEPA has indicated that any new federally issued NPDES permits for tribal wastewater facilities will also likely require compliance with the CTR.

The permit process would involve performing an analysis to assess the downstream environmental impacts. The permit would likely contain mass-based discharge limitations. The primary beneficial users of surface waters are fish. In addition to pollutant limitations, toxicity standards would be established and monitored by bioassay. Since there are no industrial discharges to the tribal wastewater system, levels of metals and other toxic components are expected to be minimal; however, it can still be assumed that any new surface water discharge in the area would have to be treated to very high standards, such as tertiary and disinfected level, before discharging to local surface waters.

5.0 Wastewater Facility

This section describes the components necessary to provide wastewater collection, treatment, and disposal service to the four project alternatives. It begins with a discussion of existing onsite facilities and then details collection, treatment, and disposal requirements. The final aspect is a preliminary level evaluation of the onsite wastewater system requirements for each alternative.

5.1 Existing Facilities

The proposed site contains eight parcels (APN: 10-200-003, 10-200-004, and 10-200-006 through 10-200-011) with existing wastewater service from the City of Plymouth. The project site is within the service boundary of the City, which maintains peripheral wastewater collection lines around the property.

5.1.1 City of Plymouth

The City of Plymouth Wastewater Treatment Plant utilizes a pond treatment system and currently receives an average daily flow of 95,000 gpd and an average five-day biological oxygen demand (BOD₅) loading of 198 lbs BOD₅/day. Additionally, the Plymouth WWTP utilizes sprayfields to dispose of its treated effluent and has a disposal capacity of 180,000 gpd.

5.2 Wastewater Treatment

A new WWTP would be required to treat wastewater discharge from the various users planned for the proposed project alternatives. Various treatment designs are possible and process selection ultimately involves consideration of many factors, including:

- Wastewater strength,
- Effluent disposal,
- Process reliability,
- Operational requirements,
- Treatment flexibility,
- Available space,
- Solid waste disposal,
- Nuisance odor,
- Visual aesthetics,
- Noise, and
- Capital and operating costs

Of the factors identified above, the method of effluent disposal and the restrictions imposed therein would have the greatest effect on the type of treatment required. The production of recycled water that meets CCR Title 22 requirements would ultimately require advanced tertiary treatment of wastewater to produce effluent containing very low concentrations of organics, solids, nutrients, and pathogens.

Due to its small layout and its ability to reliably produce high-quality effluent, membrane bioreactors (MBR) are recommended to treat wastewater for the various project alternatives. They are widely used throughout the country for flows up to 5.0 MGD and are ideal for the project's remote location where reliable wastewater treatment is critical to meeting strict discharge standards.

The MBR is a state-of-the-art, advanced wastewater treatment process that utilizes membrane technology, comparable to that used for production of potable water. The membranes are classified as microfiltration (MF) and have microscopic pores that strain solids greater than 0.1 μm to produce effluent with very low solids concentration. MBRs are also known for high rates of organics removal and can be further designed to achieve removal of nutrients, such as nitrogen (e.g. ammonia, nitrates, and nitrite) and, to a limited extent, phosphorous.

The MBR is not strictly designed for phosphorous removal although some MBR manufactures claim that a small percentage can be removed through the chemical addition of alum to promote the precipitation of phosphate out of solution. Other means of reducing phosphorous, which is true with any activated sludge process, is through the addition of an anaerobic basin in front of the anoxic basin. Typical effluent from an MBR process includes:

- < 1 mg/L BOD,
- < 0.2 mg/L $\text{NH}_4\text{-N}$,
- < 8 mg/L NO_3 ,
- < 2.2 MPN/100 mL total coliform, and
- < 0.1 NTU.

Compared to alternative wastewater treatment designs, MBRs are able to more reliably and consistently produce high-quality effluent ideal for a variety of disposal and reuse alternatives. For systems treating to tertiary-level, the cost of the MBR system also becomes cost competitive with more conventional treatment processes.

The non-economic advantages and disadvantages of the MBR system are summarized in Table 5-1.

TABLE 5-1
Non-economic Advantages and Disadvantages of the MBR

Advantages	Disadvantages
Small footprint.	Requires fine screening.
Extremely high-quality effluent; state-of-the-art treatment.	Limited equipment manufacturers.
Achieves nitrogen removal.	Relatively new process.
Combines clarification and filtration with oxidation process.	Requires emergency storage basin.
High MLSS provides resistance to loading shocks.	
Certified for CCR Title 22 use by CA DHS.	
Significantly reduces disinfection requirements.	
Provides pretreatment for TDS removal by reverse osmosis.	

5.2.1 Membrane Bioreactors

MBRs are state-of-art treatment processes designed to treat wastewater using the same principles as conventional activated sludge processes. That common, driving principle is the conversion of soluble waste into biomass. The difference is the rate at which these reactions are occurring and also the method by which the separation of solids occurs. Compared to conventional activated sludge, which relies on a clarifier for gravitational separation of solids, MBRs utilize membrane technology to physically separate the solids. The result is a more uniform effluent quality and enhanced biological treatment performance due to higher microorganism concentrations not previously possible with activated sludge due to the resulting settling problems caused by excessive solids loading to the clarifier.

MBR systems are comprised of many unit processes, which together achieve treatment of raw wastewater to produce a high-quality effluent ideal for reclamation use. A conceptual process flow diagram showing the major unit processes for the proposed WWTP is illustrated in Figure 5-1. Treatment begins upstream of the MBR at the headworks, which uses fine screens to remove large materials that can potentially damage the membrane. Wastewater from the headworks flow by gravity into the MBR structure.

The MBR process combines oxidation, clarification, and filtration into one step. A bioreactor with separate anoxic and aerobic cells provides the environment necessary for BOD₅ oxidation, nitrification, and denitrification processes to occur. High concentrations of mixed liquor suspended solids (MLSS), up to 15,000 mg/L, are maintained in the MBR tank allowing rapid synthesis of the soluble organics in the wastewater. Nitrogen removal through nitrification and denitrification is also achieved in the MBR tank between the aerobic and anaerobic tank cells, respectively.

Membrane modules immersed in an aerobic portion of the process tank combine the functions of the clarifier and tertiary filtration processes into a single step. The membranes are classified as MF and have microscopic pores that strain solids larger than 0.1 μm to produce effluent with a very low solids concentration. Having completed filtration, the membrane effluent (or a permeate) is drawn through for distribution.

Depending on the disposal point, the permeate is disinfected with either ultraviolet light (UV) or a chlorine solution. For disposal to the subsurface leachfield or sprayfield, UV is preferred since very low solids concentration minimizes shielding of bacteria, thereby producing a high pathogenic kill. As a result, UV disinfection provides efficient and consistent microbial inactivation without increased risk of chemical DBP formation. For disposal by reclamation, chlorination is preferred over UV since recycled water distribution design typically endeavors to maintain chlorine residual in the distribution system to prevent regrowth.

Waste sludge and solids residual would be disposed of by mechanical dewatering means. Waste activated sludge (WAS) and biosolids residual produced by the wastewater would be dewatered on site by means of a mechanical dewatering system and ultimately hauled off site for disposal. It is recommended that landfills in the region be contacted to determine if the landfills accept biosolids. The frequency of this operation would depend on the solids wasting frequency in the wastewater plant. All biosolids dewatering and storage facilities would be contained indoors and the foul air scrubbed to minimize odors.

The MBR WWTP would require a Grade III lead operator and Grade I or II operators to run the tertiary treatment plant based on State Standards for WWTP Operator qualifications.

Membrane bioreactors are simple the most cost effective and reliable method of treating wastewater today. Additional treatment and polishing processes can be easily added to the MBR to meet foreseeable effluent quality requirements. Other casinos utilizing MBR technology in the area surrounding the proposed Ione Rancheria Casino and Hotel include the following facilities.

- Thunder Valley Casino, Lincoln, CA – Zenon MBR
- Cache Creek Casino & Hotel, Brooks, CA – Zenon MBR
- Rolling Hills Casino, Corning, CA – Enviroquip/Kubota MBR

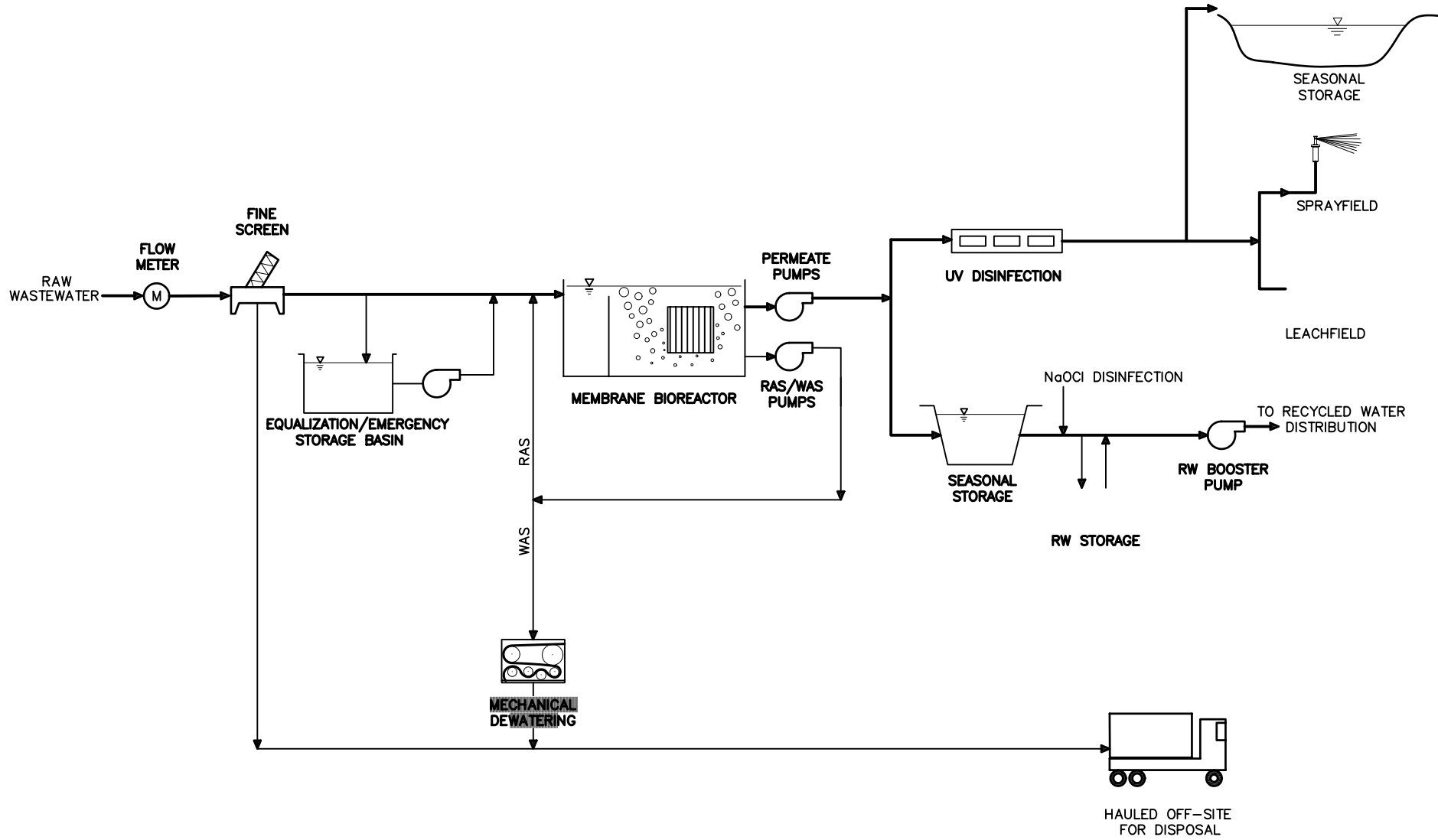

LEGEND:

- LIQUID STREAM
- SOLIDS STREAM

Figure 5-1
Ione Casino and Hotel Feasibility Study
MBR WWTP Process Flow Diagram

S:\Common_projects\Research\Ione_Renchie\W & WW Feasibility Study\AutoCAD\Figures\Fig 5-1 Low DATE:9/01/04

A preliminary level design of the recommended MBR WWTP is included in this study for each proposed alternative. Design wastewater treatment plant flows and loadings are summarized in Table 5-2 and 5-3, accordingly.

TABLE 5-2
Design Wastewater Treatment Plant Flows (gpd)

Site Layout Alternative	A		B		C	D
	Phase I	Phase II	Phase I	Phase II		
Weekday Day	105,800	126,900	90,100	111,300	63,800	23,800
Weekend Day	192,500	223,700	153,800	195,100	104,500	38,500
Average Day ^a	130,600	154,600	108,300	135,200	75,400	28,000
Design Average Day Flows ^b	200,000	200,000	200,000	200,000	100,000	30,000

^a 5/7 * week day + 2/7 * weekend day

^b Average Day flow rounded up to incremental wastewater treatment unit capacity.

Wastewater flows rounded to the nearest 100 gpd.

Estimated from similar facilities

In comparison typical average day flows for other surrounding Casino and Hotel facilities are the following.

- Thunder Valley Casino, Lincoln, CA are 175,000 gpd;
- Cache Creek Casino & Hotel, Brook, CA is 220,000 gpd;
- Jackson Rancheria Casino & Hotel, Jackson, CA is 100,000 gpd; and
- Rolling Hills Casino 40,000 gpd.

TABLE 5-3
Estimated Average Day Wastewater Loads (lbs/day)^a

Site Layout Alternative	A		B		C	D
	Phase I	Phase II	Phase I	Phase II		
BOD ₅	650	780	540	680	380	100
TSS	600	710	500	620	350	90

^a Loadings rounded up to the nearest 10 lbs/day.

5.2.2 Facility Design

Facility design of the MBR WWTP was completed on a preliminary level. A conceptual site layout was included previously on Figure 3-2 to 3-7 showing major facility sizes and locations for treating 200,000, 100,000, or 30,000 gpd average day wastewater, accordingly. Future additional facilities are also shown to illustrate possible expansion designs. Unit process summaries for major processes are included in Table 5-4.

It should also be noted that the following treatment plant facility descriptions may require slight modifications upon the selection of a MBR manufacturer due to variations in process theory between manufacturers and patented products.

Grease Interceptors The Uniform Plumbing Code (UPC) requires that all kitchen waste be directed through a grease trap prior to entering into the sanitary sewer collection system. In a municipal collection system the community or regional WWTP influent fats, oils, and grease (FOG) levels are reduced as the FOG is diluted by other residential and commercial waste streams. In a Casino and Hotel project where there are typically many food services and the wastewater stream is not as diluted by flows from toilet, shower, and laundry facilities the onsite WWTP influent may have a higher than normal FOG concentration. It is standard practice to install passive grease interceptors. Additional FOG removal can be obtained by installing active mechanical grease separators in the drain lines of the restaurants sinks and select equipment.

A passive grease interceptor is a two stage water tight in-ground concrete tank designed to cool wastewater so that fat may solidify and to slow the velocity of the wastewater stream to allow for separation of the fats, oils, and greases from the water. The passive grease interceptor must be regularly cleaned to remove the accumulated floating and settled solids. Sizing and placement requirements for passive grease interceptors can be found in the UPC. It is recommended that the passive grease interceptor be designed conservatively.

An active mechanical grease separator is typically small enough to be installed under or near the kitchen sink or equipment generating high FOG concentrations. The device skims the FOG waste from the water and stores it in a waste container for disposal. Multiple active grease separators are typically required to reduce the FOG from each point source. Refer to the grease separator manufacture for sizing and placement of units.

A combination of passive and active grease interceptors may be required to reduce the FOG concentration to a level recommended by the WWTP manufacturer.

Headworks. Headworks facilities would consist of flow measurement and screening equipment. Typical plan and section drawings are illustrated in Figure 5-2. Wastewater pumped by the raw wastewater lift stations to the headworks would enter the influent pipe, which would be reduced to a 3-inch diameter pipe upstream of a magnetic flow meter. After flow measurement, the pipe would discharge to a covered headworks influent box for distribution to the screening channels. Slide gates would control flow to the screening channels.

Fine screening (< 1.5 mm) would be required for protection of the MF membranes. A provided bypass around the screen would act as an emergency overflow in case of mechanical or electrical failure. The headworks screening channel would be sized to handle the peak wastewater flows for each alternative.

Screening would be accomplished by a self-cleaning inclined cylindrical sieve screen with an integral screenings scraper/conveyor, compactor, and mechanical washer system. A 1.5-mm screen size would be required to protect the MF membranes from hair and stringy material. The cylindrical screen fits into the channel at one end. As the water level rises in the influent channel, a shaftless helical screw pushes the solids down into the channel where a mechanical washer system breaks up fecal material so that it can pass through the screen to the treatment plant. Then the screw reverses directions in order to pull the remaining inorganic solids upwards to a compactor. Compacted screenings fall into a bin via a discharge chute. Excess liquid from the compactor flows back to the channel.

The headworks channel and screen system would be covered. Foul air from the headworks facilities would be scrubbed for odor removal, which would be accomplished in a soil filter. This eliminates the need for chemicals and simplifies operational requirements typical for a chemical scrubbing system.

Immersed Microfiltration Membrane Bioreactor. The MBR system combines a suspended growth biological reactor with membrane filtration. Each MBR process train would consist of an anoxic zone for denitrification, an aeration zone for soluble BOD reduction and nitrification, and a membrane filtration zone for solids removal. Two MBR trains would be provided, each sized to handle half of the peak design wastewater flow. This would allow one process train to be taken off line for maintenance during off-peak days at the gaming facility. The MBRs would typically produce an effluent with BOD and TSS levels of less than 2 mg/L, and a turbidity of less than 0.1 NTU. The components of the MBR are described below.

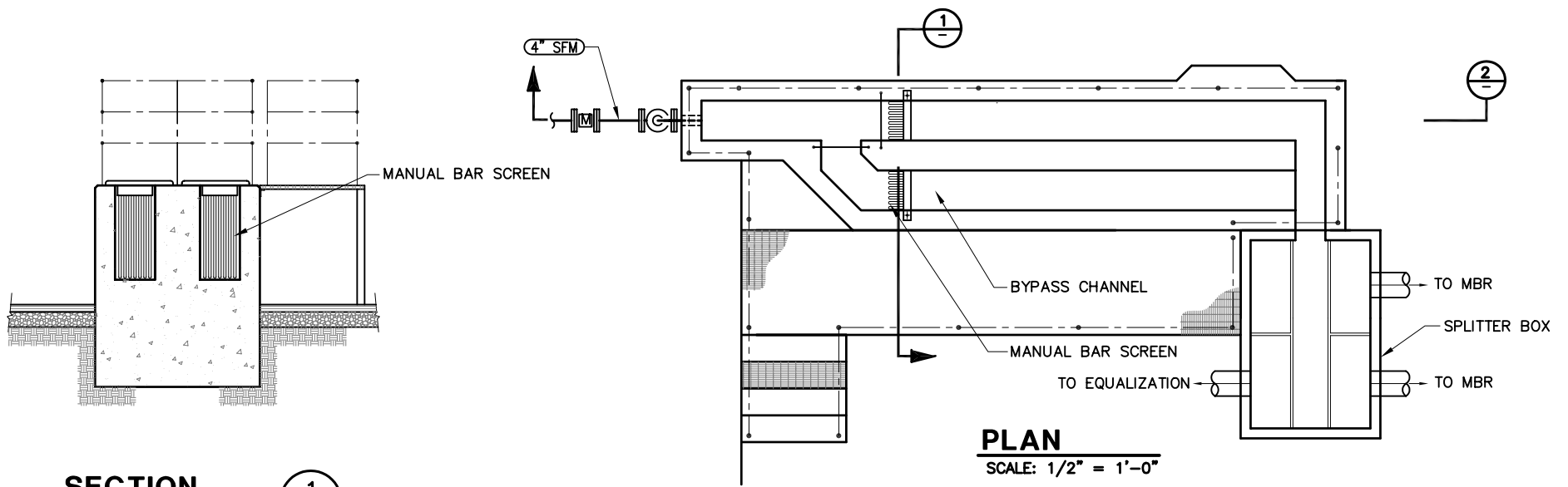

SECTION
SCALE: 1/2" = 1'-0"

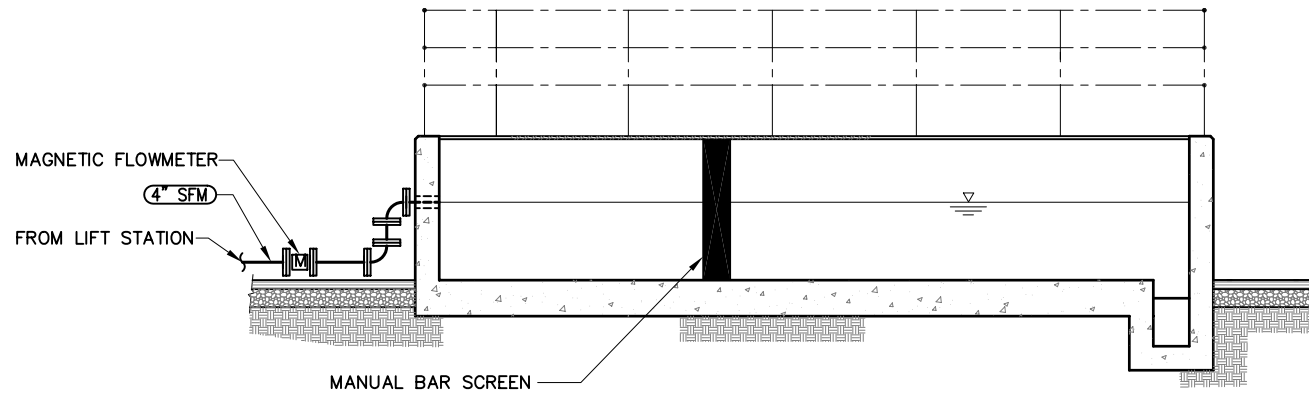

Figure 5-2
Ione Casino and Hotel Feasibility Study
Typical Headworks

Anoxic Zone. An anoxic basin would be provided for each process train. Nitrate removal, a process called denitrification, is accomplished in this basin by a suspended growth bacterial process that thrives in an anoxic environment. In the absence of oxygen, denitrifying bacteria obtain energy for cell growth from the conversion of nitrates to nitrogen gas. The hydraulic retention time (HRT) would be approximately 8 hours for complete denitrification. The incoming raw wastewater provides a continuous carbon source needed for denitrifying bacteria cell synthesis.

In addition, some carbon would be supplied in the recirculated biomass through endogenous decay. The anoxic zones would be equipped with mechanical mixers to aid in the denitrification process. From the anoxic zones, the wastewater would flow to the aeration tanks.

Aeration Zone. An aeration basin would be provided for each process train. Wastewater entering the tank would be aerated by process air blowers, supplied through a fine bubble diffuser system installed at the bottom of the aeration tank. Soluble organics are converted into biomass by an aerobic suspended growth process. In this process, microorganisms utilize the carbon in the wastewater for energy and cellular synthesis. The recirculated mixed liquor entering the aeration basin from the anoxic basin provides a continuous source of bacteria. Conversion of ammonia to nitrates, called nitrification, occurs in the aeration basin. Nitrifying bacteria incorporate ammonia-nitrogen into respiration and cell synthesis processes and produce nitrates as a byproduct.

Membranes. The membranes would be located in the corner of the aeration basin for each process train. Membrane cassettes would be immersed in each basin; each cassette would contain eight membrane modules. A membrane module consists of a bundle of hollow microfiltration or ultrafiltration fibers, with a typical nominal pore size of approximately 0.1 μm .

A vacuum would be applied to the module headers to draw the wastewater from the process tank through the membrane. Wastewater would then flow through the hollow fibers to a permeate pump. The permeate pump would transfer the wastewater to the UV disinfection facilities or to the seasonal storage reservoir.

Mixed liquor from the membrane zone would be continuously recycled back to the anoxic zone by a recycle pump in each membrane tank. This oxidized and nitrified recycle stream would be blended with raw sewage, which is a source of carbon source, to enable denitrification to occur in the anoxic zone. Periodically, a sludge waste pump located in each membrane zone would waste excess mixed liquor to the belt filter press where it is dewatered and eventual hauled off site for disposal.

Air is fed to the underside of the membranes to prevent solids from binding on the surface of the membranes. Piping and backwash storage tanks would be provided for periodic backwash of the membranes. Five backwash storage tanks would be provided, each with a storage capacity of approximately 3,000 gallons. The backwash tanks would

be filled with permeate from the MBRs. Sodium hypochlorite would be added to the backwash for control of regrowth on the membrane strands. It is expected that the chlorine demand in the permeate would consume any chlorine introduced by the backwash cycle.

An overhead crane with a traveling bridge would be provided for maintenance use. The crane would be used to maneuver membrane cassettes for service and/or soak cleaning in a chemical dip tank (containing a mild sodium hypochlorite solution) located at the end of the basin structure. Chemical pumps would be provided for transfer of sodium hypochlorite to the dip tank.

The sodium hypochlorite solution (chlorine solution) used to backwash the filters would be mostly consumed by the wastewater during the cleaning process. Any residual chlorine would be used as the water is recirculated throughout the anoxic and aerobic basins.

Disinfection:

1) UV Disinfection. Membrane-filtered effluent is well suited for disinfection by UV light due to the very low solids content. UV disinfection would eliminate the need to store large quantities of disinfectant chemicals, such as sodium hypochlorite. An additional benefit is that disinfection by-products are not formed.

UV disinfection facilities would be provided for disinfection of wastewater prior to subsurface disposal or spray field disposal. The proposed UV disinfection facilities would typically be located adjacent to the MBR basins. UV disinfection is accomplished by a bank of UV lamps contained in a stainless steel channel with a built-in weir-level control system.

Dosage requirements and certain operational features and controls of the UV system would meet Title 22 recycled water requirements. UV disinfection lamps would utilize low-pressure, high-intensity lamps. A packaged control system would be supplied by the UV system vendor.

2) Chlorine Disinfection. A hypochlorite feed system would be used to provide chlorination to the recycled water prior to being pumped into the recycled water storage tank. Chlorination disinfects the treated wastewater while maintaining a chlorine residual of 1–2 mg/L in the storage tank and the dual-plumbed piping system. This low residual should be effective in preventing any regrowth in the recycled water distribution system. The contact time needed for complete mixing of the solution would be accomplished in the recycled water distribution piping.

Recycled Water Pump Station. A recycled water pump station would be required for recycled water distribution. The size and type of pumps required would be determined based on the hydraulic flow and storage characteristics and requirements of the system.

Emergency/Equalization Storage Basin. The emergency/equalization storage basin (E/ESB) is located within the WWTP site and is intended to serve two functions. As an equalization basin, the E/ESB is intended to attenuate peak influent flows by diverting excess wastewater upstream of the MBR tank. This ensures that the MBR receives a relatively constant flow of wastewater. Once influent flows have subsided, the stored wastewater is returned to the treatment train.

In addition, the E/ESB can also serve as a temporary storage reservoir in the event that the MBR is not in service. In the event of complete mechanical shut-down or failure, raw wastewater would be screened by the headworks via a manually-screened overflow channel and be diverted to the E/ESB for emergency storage by gravity. When wastewater treatment systems are online again, the stored wastewater can be pumped back into the process train for treatment.

Mechanical Dewatering. The mechanical dewatering system would be located within a building on the WWTP site to provide odor control in the vicinity of the dewatering equipment. The mechanical dewatering system would be designed to meet *Code of Federal Regulations Title 40: Protection of Environment – Part 503: Standards for the Use or Disposal of Sewage Sludge* (CFR 40 Part 503). The mechanical dewatering system would produce either Class A or Class B biosolids depending on the selected disposal method. A more comprehensive analysis examining expected sludge quality, mechanical dewatering equipment, disposal facilities in the vicinity of the project site (Jackson Rancheria is currently sending biosolids from their WWTP to Forward Inc. Landfill located in Stockton, CA), and cost of operation would be required prior to the selection of Class A or Class B biosolids and prior to selection of the mechanical dewatering system.

Operations Building. An operations building would be required to house the plant controls, the motor control center, the blowers required for the MBR process, the chemical storage and handling facilities, and other mechanical equipment. A preliminary plan of the building is shown in Figure 5-3. The building would also include a maintenance room. A small laboratory would be provided for on-site testing and sample preparation. In addition, a small locker room with showers would be provided. Roll-up doors would be provided for entry to the blower room. Double-doors would provide access to the electrical and chemical rooms.

The building would be a masonry, single-story structure with a standing seam-painted metal roof. A combination of plain block and split-face block would be used. Interior walls would be either masonry or metal stud with drywall. Suspended ceiling and lighting panels would be provided in some rooms with utilities and ventilation ducting in the overhead space.

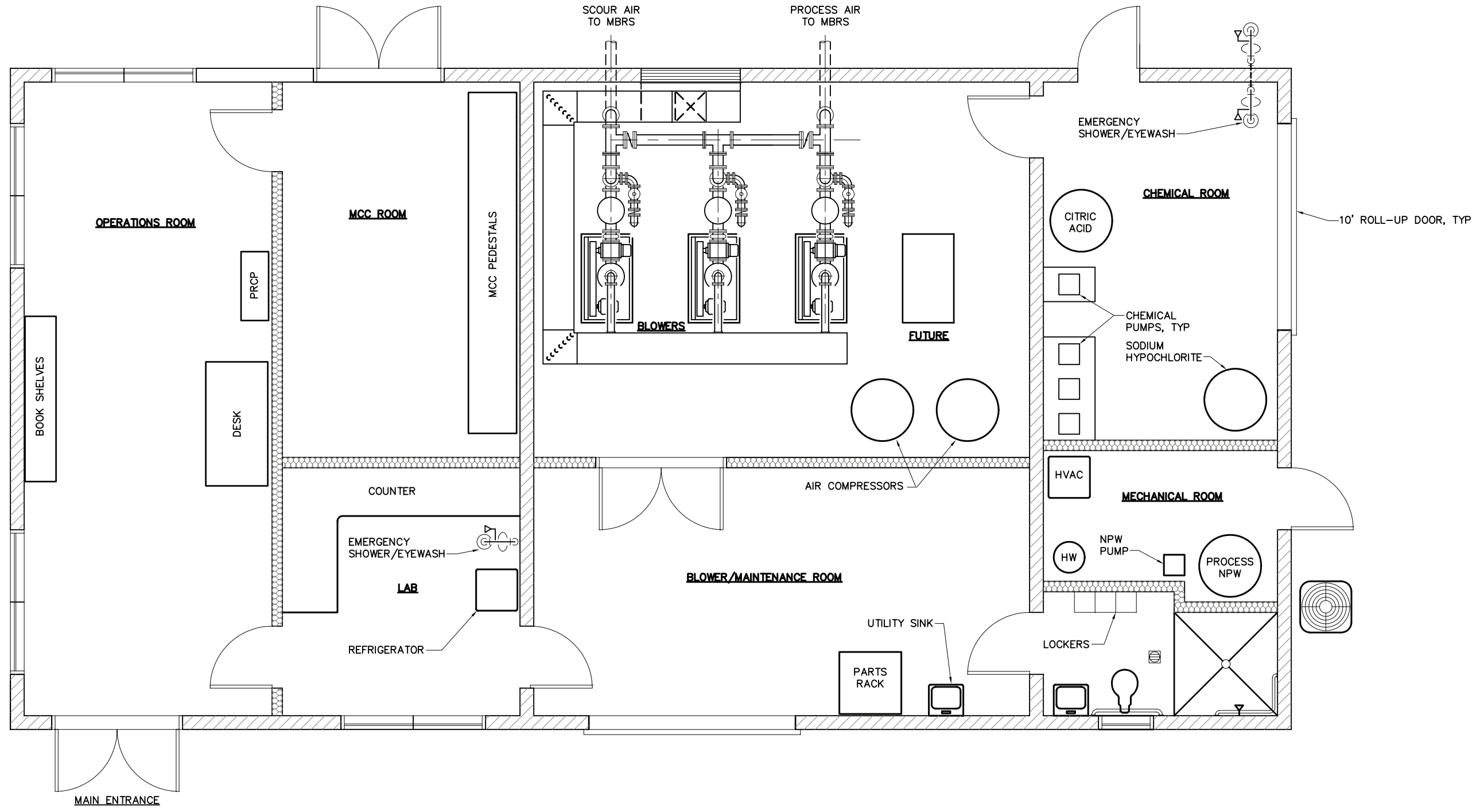

PLAN
SCALE : 3/16" = 1'-0"

S:\common_projects\Rancheritas\New Rancherita\W & WW Feasibility Study\AutoCAD\Figures\Fig 5-3.dwg DATE:9/01/04

A summary of unit processes information and general design criteria are further summarized in Table 5-4.

TABLE 5-4
Unit Process Summary for the MBR WWTP for Alternative A, B, and C ^a.

Unit process	Design criteria	Size	Total units
Flow meter	Magnetic flow meter on influent pipe	Peak hour flow	1
Fine screen	3-mm perforations 2 fps approach velocity	TBD	1 plus 1 bypass
Anoxic basin	8-hr HDT 12-ft. operating depth 14-ft total depth	TBD	2
Aeration basin	13-hr HDT	TBD	2
Immersed membrane	TBD based on selected manufacturer.	30,000, 100,000, or 200,000 gpd (Based on selected alternative)	2
Recirculation pumps	Submersible centrifugal non-clog constant speed	TBD	1 per basin
Air blowers	Positive displacement constant speed	TBD	2 duty 1 standby
Permeate pumps	Flexible impeller Variable frequency drive (VFD)	TBD	2 duty 1 standby
Backpulse pump	Horizontal end suction centrifugal Constant speed, timed sequence	TBD	1 duty 1 standby
Backpulse tank	150 gpm per backpulse 2-min. duration Polyethylene	TBD	1
Emergency/equalization storage basin	Storage capacity for 1-day average day flow	TBD	1
Seasonal storage reservoir	To be determined by others.	TBD	TBD
UV disinfection	total coliform 23 MPN per 100 mL sample	TBD	1 channel
Chlorination	minimum 450 mg-min/L CT, 90 minutes minimum modal contact time	TBD	1
Mechanical Dewatering System	Located indoors for odor control	TBD	TBD
Plant drain and supernatant return pump station	Pumped back to headworks Submersible non-clog	100 gpm, each	1 duty 1 standby

^a Not representative of the design criteria for Alternative D.

^b Design 3criteria based on a peak wastewater flow of 200,000 or 400,000 gpd

5.2.3 Facilities Layout

Figures 3-2 to 3-7, shown previously, show proposed site locations for the microfiltration wastewater treatment plant on the proposed project site. Both the Water Treatment and Wastewater Treatment plants would be located to the south of the proposed main parking lot. Wastewater generated from the gaming facilities would flow by gravity to an influent pumping station, which would lift the wastewater to the headworks facilities. After passing through the headworks metering and screening facilities, the wastewater would flow by gravity to the influent distribution channel upstream of the anoxic basins at the MBR facilities. Wastewater would flow from the influent channel to the anoxic basins and the aeration basins as described above. The permeate pumps would convey the treated effluent to the

The operations building would be located north of the MBR facilities and the sludge stabilization basins. The operations building would visually shield most of the WWTP facilities from the gaming facility and parking lot. If desired, the operations building could match the architectural features used at the gaming facility. A circular interior plant roadway would be constructed to allow vehicle access to all portions of the MBR facilities and operations building.

5.2.4 MBR Capital Equipment Cost

MBR capital equipment cost estimates were obtained from various manufacturers for a microfiltration wastewater treatment system for each of the proposed alternatives. The estimated capital costs are summarized in Table 5-5. The MBR capital equipment cost estimates include only the MBR equipment (i.e. the membranes, permeate pumps, air blowers, air diffusers, mixers, screens, instrumentation) for comparison purposes due to the complexity of sizing of a WWTP. Additional capital costs for the other facilities associated with a microfiltration wastewater treatment plant (i.e. operations building, sludge stabilization basin, dewatering equipment, ultraviolet disinfection, chlorine contact basin, disposal fields, etc.) are not included at this time. An economic analysis would be conducted upon the selection of an alternative.

TABLE 5-5
Capital Cost Estimates ^a

	Ionics	Enviroquip	Zenon
Alternative A (0.2 MGD WWTP)	\$649,000	\$555,000	\$511,000
Alternative B (0.2 MGD WWTP)	\$649,000	\$555,000	\$511,000
Alternative C (0.1 MGD WWTP)	\$519,000	\$420,000	\$434,000
Alternative D (0.03 MGD WWTP)	\$103,000	--	--

^a Costs are rounded to the nearest \$1,000.

5.3 Recycled Water

This section discusses the recommended design criteria for the Project's recycled water facilities. The recommended onsite water facilities include:

- Reverse Osmosis Treatment System (if required),
- Recycled Water Storage Tank,
- Recycled Water Pump Station,
- Onsite Irrigation/Dual Plumbing Facilities,

Each of these facilities is described in the following sections.

5.3.1 Reverse Osmosis Treatment System

An RO system would be required, if the treated effluent from the WWTP does not meet the governing agency's TDS requirements for effluent disposal via reuse, subsurface disposal, or surface water disposal. This RO system would be designed similarly to the drinking water RO system.

The RO system removes dissolved minerals and salts from the water stream and produces water that is low in inorganic salts, organic matter, and bacteria. In the RO system, the influent stream passes across and through sheets of specialized semi-permeable membranes under high pressure. The membranes block the passage of dissolved minerals (with molecular weight over 100) while allowing the water to pass through. The water that passes through the membranes is called permeate or product. The mineral rich stream that the membranes reject is called reject or concentrate. The permeate water can be used as a direct feed to a distribution system, or stored in a reservoir or storage tank.

The reject stream would be then run through an additional RO unit to further concentrate the brine and minimize the water wasted. The brine would require disposing of. A similar system at Thunder Valley currently sends their brine to East Bay Municipal Utility District (EBMUD) for a fee based on the amount of brine.

5.3.2 Recycled Water Storage Tank

The purpose of this tank would be to provide equalization storage for onsite recycled water use used in the building for toilet flushing, onsite landscaping, and for sprayfield irrigation. The tank would be sized such that it will provide equalization for peak flows, as well as provide emergency storage for the recycled water system, thereby allowing for a more steady flow to be sent to the RW distribution system. Should seasonal storage facilities be constructed, the water would also be pumped to the seasonal storage basins from this storage tank. If desired, recycled water could be utilized to supply water for fire suppression, such as the sprinkler systems and fire hydrants.

A typical section for the storage tank is shown as Figure 5-4. The recycled water storage tank would be constructed near the wastewater treatment plant site. The storage tank would not maintain pressure in the recycled water distribution system. This storage tank would be similar to the potable water storage tank with respect to construction methods. Summarized in Table 5-6 are the recommended recycled water storage capacities for the four alternatives.

TABLE 5-6
Recycled Water Storage Tank Requirements (gallons)

Site Layout Alternative	A		B		C	D ^a
	Phase I	Phase II	Phase I	Phase II		
Average Day Recycled Water Demand	52,000	62,000	43,000	54,000	30,000	n/a
Recycled Water Storage Tank Capacity	208,000	248,000	172,000	216,000	120,000	n/a
Recommended recycled water storage capacity	250,000	250,000	250,000	250,000	250,000	n/a

^a Alternative D does not include recycled water.

^b 4.0 times the average day demand

^c Rounded up a common tank size increment.

^d Water demands rounded up to the nearest 1,000 gal.

5.3.3 Recycled Water Pump Station

Three separate recycled water pump stations are required for the recycled water facilities. All of the required pump sizes and configurations would be dependent on the overall wastewater discharge strategy. However, the strategy described below assumes that seasonal storage is utilized, recycled water is produced and maximized onsite, and that the flows are similar to those identified in Section 2.

The first pump station would pump water from the wastewater treatment plant to the storage tank. This pump station is expected to be a low head pump station with a hydropneumatic tank that fills the recycled water tank to provide system storage.

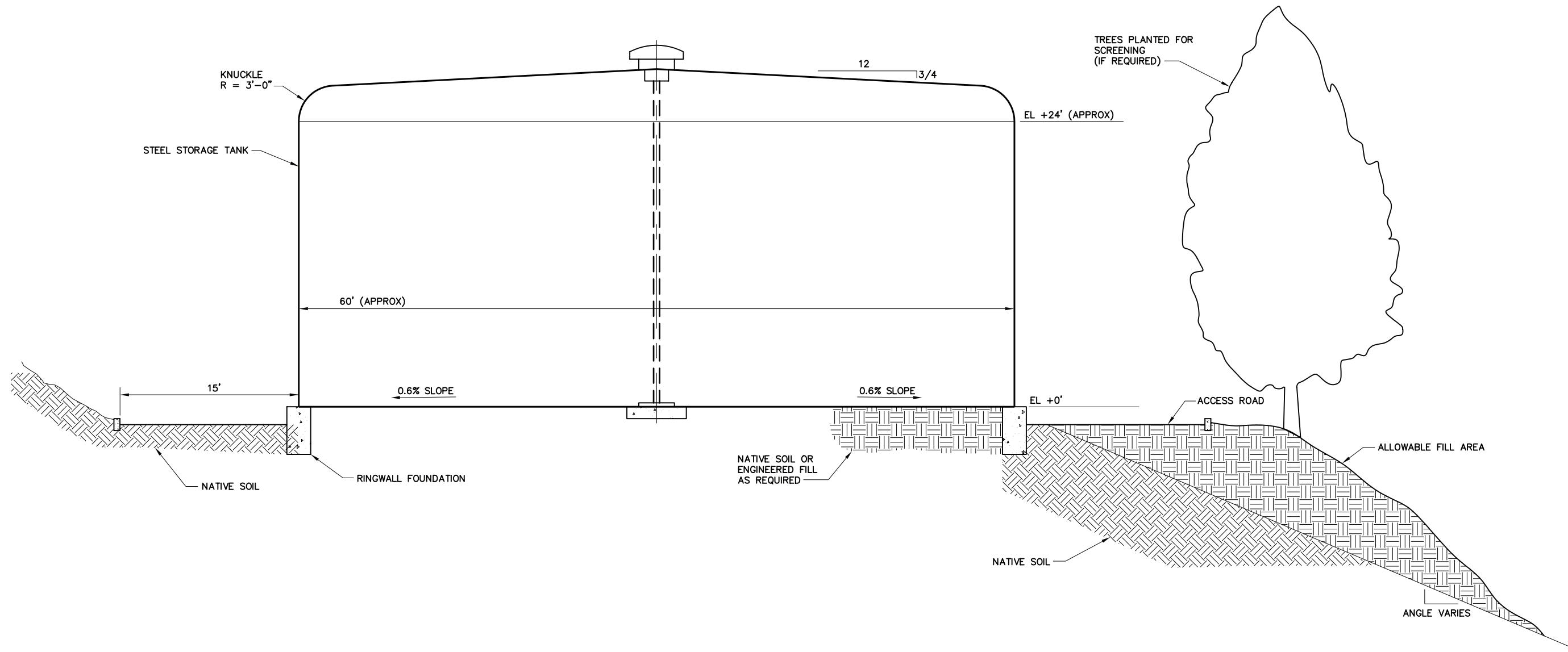

ELEVATION
NTS

S:\COMMON\PROJECTS\DRY_CREEK_RANCHERIA\DWGS\F104-2.DWG DATE: 08/24/00



Figure 5-4
Ione Casino and Hotel Feasibility Study
Typical Recycled Water Seasonal Storage Tank

The second pump station would pump water from the recycled water storage tank to the recycled water distribution system. This pump station would likely need to continuously operate, since there will be no system storage. There are no suitable sites for a recycled water storage tank at an elevation that would all gravity to maintain pressure in the distribution system.

The third pump station would pump out of the season storage ponds to the sprayfields for irrigation. These pumps will operate seasonally, typically between March and October, and would be sized to convey the entire volume of recycled water stored in the seasonal storage ponds plus a portion of the daily summertime wastewater flows within a 5-day week, 8-hours per day time period between March and October.

5.3.4 Onsite Water Reuse Facilities

This report assumes that the facilities for the selected alternative will be dual-plumbed with both potable and recycled water. The primary uses of recycled water will be for toilet flushing, onsite landscape irrigation, and cooling water. The onsite recycled water reuse facilities will be designed to ensure that they comply with all DHS standards. The required onsite facilities will be identified upon completion of a site plan and preliminary engineering. The primary onsite design requirements include:

- Recycled water irrigation facilities marked in a purple color.
- Signage informing the public recycled water is used.
- Pipelines in separate trenches a minimum distance away from other water pipelines.
- Labeling of recycled water valves, boxes, and sprinkler heads.

Within the building, the interior plumbing system will have to be plumbed separately from the building's potable water system, and contain no cross connections. The dual-plumbing piping systems must be distinctly marked and color-coded.

5.4 Effluent Disposal

The proposed WWTP for alternatives A, B, C, and D will produce recycled wastewater effluent meeting Title 22 tertiary treatment standards. This effluent may be dispersed to sub-surface leachfields, sprayfields, landscape irrigation, and seasonal storage ponds. Summarized in Table 5-7 are the estimated effluent disposal requirements for each of the four alternatives. Due to limited on and off site water supply it is recommended that recycled water be utilized for the flushing of toilets and urinals within the casino and that recycled water be used for landscape irrigation.

It is recommended that the use of recycled water be maximized for this project. Reuse will benefit this project in two ways. First, the reuse of recycled water will reduce the potable water demand. The supply of potable water from onsite and offsite wells and

local water agencies is limited. Second, the reuse of recycled water will reduce the flow of treated wastewater effluent to the onsite disposal systems. Thereby reducing the overall required disposal capacities, sizes, soil application rates, or operational parameters. Table 5-7 shows average day wastewater flows to be treated, the recycled water demand and the difference which is the average day disposal flow. It is assumed that recycled water use would be maximized onsite, thus reducing the overall effluent disposal requirements. Other operating facilities such as Thunder Valley Casino, CA and Cache Creek Casino & Hotel have historically recycled approximately 40% +/- of the wastewater flow for recycled water use.

TABLE 5-7
Design Wastewater Disposal Flows with Recycled Water (gpd)

Site Layout Alternative	A		B		C	D
	Phase I	Phase II	Phase I	Phase II		
Average Day Wastewater Flows ^a	130,600	154,600	108,300	135,200	75,400	28,000
Recycled Water Demand	52,200	71,800	43,300	64,100	40,200	n/a
Average Day Disposal Flows ^c	78,400	83,000	65,000	71,100	35,200	28,000
Design Average Day Disposal Flows ^d	80,000	90,000	70,000	80,000	40,000	30,000

^a 5/7 * week day + 2/7 weekend day

^c Wastewater flow less recycled water

^d Design Disposal Flow rounded to nearest unit.

Wastewater flows rounded to the nearest 100 gpd.

5.5 Water Balance

Based on a report prepared by AEG on the soil mantle and percolation rates located onsite, it is recommended that sprayfield irrigation be primary disposal method due to limiting onsite soil conditions. AEG also found that subsurface disposal should be made at low application rates (not to exceed 0.2 gpd/ft²), and that subsurface disposal should not be done at high elevations (above 1,125 feet) where the soil layer is thinner (AEG, 2004). A copy of the results of the soil mantle and percolation tests is included in Appendix D.

Utilizing the recommendations made by AEG, a water balance was conducted to determine the disposal area requirements for each project alternative. Table 5-8 summarizes the results from the water balance analysis performed by HSe. A copy of the more in depth analysis is included in Appendix E.

TABLE 5-8
Water Balance and Wastewater Disposal Requirements

Site Layout Alternative	A		B		C	D
	Phase I	Phase II	Phase I	Phase II		
Design Average Day Disposal Flows (gpd) ^a	80,000	90,000	70,000	80,000	40,000	30,000
Landscape Irrigation (acres)	2.0	2.0	2.0	2.0	2.0	n/a
Spray Disposal (acres)	13.7	13.7	13.7	13.7	13.7	5.2
Sub-Surface Disposal (acres)	2.9	2.9	2.9	2.9	0.0	3.5
Seasonal Storage Reservoir (MGal)	10.3	10.3	8.9	8.9	4.7	n/a

^a Design Disposal Flow rounded to nearest 1,000.

The alternative seasonal storage reservoirs are only preliminarily sized in this report, and shall be sized and designed by a licensed engineer according to the standards as specified by the Dam and Reservoir Division of the Bureau of Indian Affairs (BIA). It is assumed that the BIA will follow the Federal Department of Dam Safety (DODS) standards. In addition, the seasonal storage reservoir shall be enclosed by a fence in order to restrict access to approved personnel.

6.0 Conclusions

Each of the four projective alternatives was evaluated and found to be feasible in terms of water, wastewater, and recycled water service. The potable water supply requirements can be satisfied through a combination of supplies, which include the City of Plymouth, onsite wells, offsite wells, trucking, and the Amador Water Agency. As recycled water becomes available for use, it will be supplemented for toilet flushing, landscape irrigation, and process water in the cooling towers. Wastewater service could be provided by a tertiary wastewater treatment plant constructed to produce high quality effluent suitable for reuse. Specific conclusions are summarized below.

Table 6-1 contains a summary of the demands and flows for the four project alternatives.

TABLE 6-1
Summary of Demands and Flows

Site Layout Alternative	A		B		C	D ^g
	Phase I	Phase II	Phase I	Phase II	(gpd)	(gpd)
	(gpd)		(gpd)		(gpd)	(gpd)
Recycled Water						
Average Day Recycled Water Demand ^a	52,200	61,800	43,300	54,100	30,200	n/a
Recycled Water Storage ^b	250,000	250,000	250,000	250,000	150,000	n/a
Water						
Water Demand without Recycled Water ^c	170,200	200,300	148,500	178,600	111,700	36,600
Water Demand with Recycled Water	108,000	128,500	95,200	114,500	71,500	36,600
Recommended Pumping Rate without Recycled Water (gpm)	120	140	105	125	80	25
Recommended Pumping Rate with Recycled Water (gpm)	75	90	70	80	50	25
Domestic Water Storage ^d	2,000,000	2,000,000	2,000,000	2,000,000	2,000,000	500,000
Wastewater Treatment						
Weekday Day Wastewater Flow	105,800	126,900	90,100	111,300	63,800	23,800
Weekend Day Wastewater Flow	192,500	223,700	153,800	195,100	104,500	38,500
Average Day Wastewater Flow ^e	130,600	154,600	108,300	135,200	75,400	28,000
Design Average Day Wastewater Flows ^f	200,000	200,000	200,000	200,000	100,000	30,000
Wastewater Disposal						
Design Average Day Disposal Flows ^h	80,000	90,000	70,000	80,000	40,000	30,000
Landscape Irrigation (acres)	2.0	2.0	2.0	2.0	2.0	n/a
Spray Disposal (acres)	13.7	13.7	13.7	13.7	13.7	n/a
Sub-Surface Disposal (acres)	2.9	2.9	2.9	2.9	0.0	3.5
Seasonal Storage Reservoir (MGal)	10.3	10.3	8.9	8.9	4.7	n/a

^a Estimated at 40% of average day domestic water demand.

^b Operational storage only. Does not include fire hydrant storage.

^c Average day water demand, including landscape irrigation.

^d Two – 1 million gallon domestic water storage tanks per arrangement between the Tribe, the developer, and the City.

^e 5/7 * weekday day + 2/7 * weekend day

^f Week end day flow rounded up to incremental wastewater treatment unit capacity.

^g Alternative D does not include recycled water.

^h With recycled water.

6.1 Water Supply

Water supply can be provided by a combination of sources. Sources of potable water include onsite and offsite wells, which would require further treatment before entering into the project's water distribution system, as well as trucking water to the project site from a local distributor. Refer to Table 6-1 for potable water requirements for the four project alternatives.

Recycled Water can significantly reduce water demand. Experience with the use of recycled water for non-potable applications as an alternative water supply source significantly reduces potable water demand. The potable water demand with recycled water for each of the four alternatives is also included in Table 6-1.

An onsite water treatment plant to remove iron and manganese may be required. If the use of onsite and offsite wells are used to supplement the required potable water demand a water treatment plant will be required based on preliminary water quality testing from the wells. Additional treatment is not required for potable water supplied by the local distributor trucking in water. An onsite reverse osmosis system may be required to decrease total dissolved solid (TDS) concentrations in the ground water.

The project may also require the construction of the following water supply facilities: onsite wells, offsite wells, iron and manganese treatment plant, reverse osmosis treatment system, steel water storage tanks, a water distribution pump station, a steel recycled water storage tank, and a recycled water distribution pump station.

6.2 Wastewater Treatment and Disposal

An onsite tertiary wastewater treatment plant is recommended. The tertiary WWTP is capable of producing high quality effluent meeting Title 22 regulations for recycled water. The maximization of recycled water use will help to reduce the potable water demand. Estimated MBR capital equipment cost estimates for the microfiltration treatment plant for comparison purposes are summarized in Table 6-2.

TABLE 6-2
Capital Cost Estimates ^a

	Ionics	Enviroquip	Zenon
Alternative A (0.2 MGD WWTP)	\$649,000	\$555,000	\$511,000
Alternative B (0.2 MGD WWTP)	\$649,000	\$555,000	\$511,000
Alternative C (0.1 MGD WWTP)	\$519,000	\$420,000	\$434,000
Alternative D (0.03 MGD WWTP)	\$103,000	--	--

^a Costs are rounded to the nearest \$1,000.

Spray irrigation should be the primary method of onsite disposal, if surface water discharge is infeasible. It is recommended that the primary method of onsite disposal be spray disposal, if surface water discharge is infeasible. The soil mantle and percolation test report by Applied Engineering and Geology (AEG) indicates that the site exhibits a thin layer of surface soils over highly fractured slate and shale with slow percolation rates. Subsurface disposal is limited to a small area of the proposed disposal site. It is recommended that a recycled water seasonal storage reservoir be used in conjunction with a large sprayfield and a small subsurface leachfield for disposal. It is also recommended that any area used for either spray disposal or for subsurface disposal be periodically mowed to allow for ground inspection. See Table 6-1 for disposal and storage requirements for each of the four project alternatives. The alternative seasonal storage reservoirs are only preliminarily sized in this report, and shall be sized and designed by a licensed engineer according to the standards as specified by the Dam and Reservoir Division of the Bureau of Indian Affairs (BIA). It is assumed that the BIA will follow the Federal Department of Dam Safety (DODS) standards. In addition, the seasonal storage reservoir shall be enclosed by a fence in order to restrict access to approved personnel.

6.3 Preferred Site Alternative

The preferred project alternative is Alternative A, Phase I and Phase II. Alternative A, Phase I and Phase II, consists of constructing a casino with 2,000 slot machines, 40 table games, and restaurant/bar areas during its first phase of operation. And during the second phase of operation, Alternative A proposes to construct a 250-room hotel and 1,200 seat event center. Table 6-1 summarizes the water supply requirements, as well as, the wastewater treatment and disposal requirements. The water demand for the preferred alternative would require multiple sources (Onsite/Offsite Wells, and Trucking) to satisfy the project water requirements. Figure 6-1 presents an overview of the treatment processes for both water and wastewater for this project scenario without recycled water usage.

It is recommended that recycled water use be maximized in order to reduce the requirements for potable water and to reduce the amount of treated effluent that needs to be disposed. If recycled water use is maximized, the water supply requirements could be met by onsite and offsite wells, or by a combination of supplies (Onsite/Offsite Wells and Trucking). Figure 6-2 present an overview of the treatment processes for both water and wastewater for this project scenario with maximized recycled water usage.

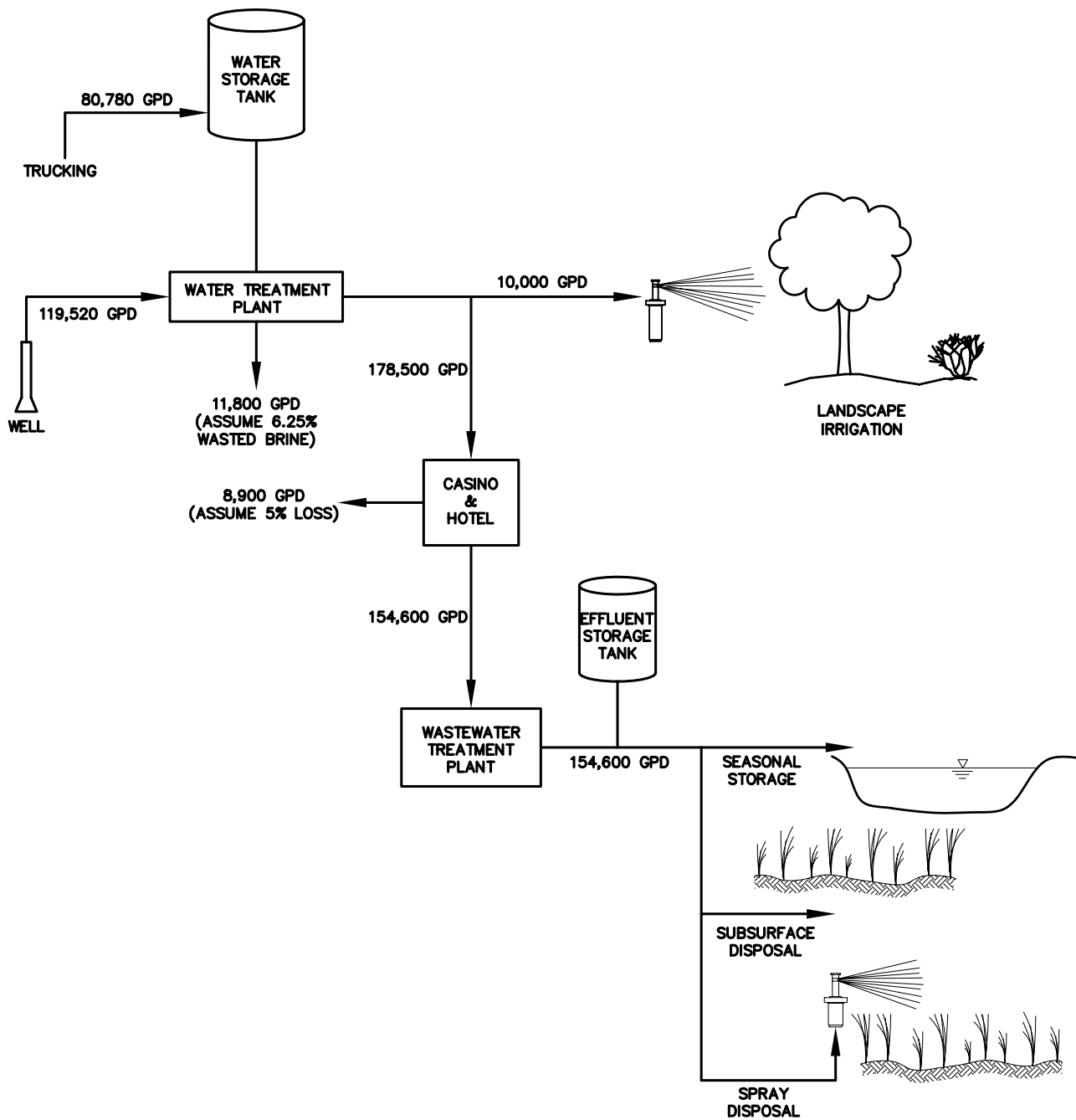

S:\common_projects\Rancheria\Research\W & WW Feasibility Study\AutoCAD\Figures\Fig 6-1A.dwg DATE:8/23/05

Figure 6-1
lone Casino and Hotel Feasibility Study
Flow Diagram without Recycled Water for Alternative A

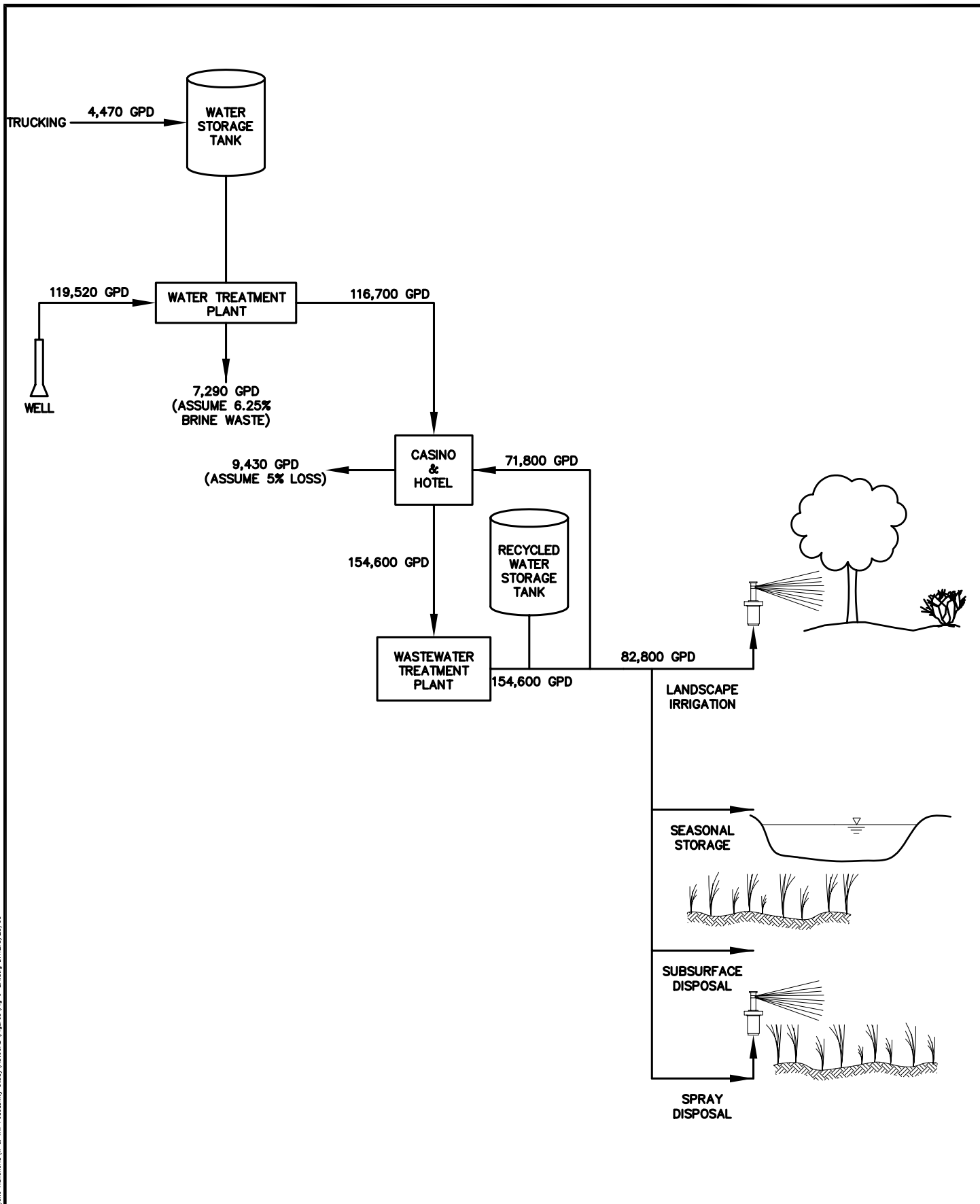

S:\Common_projects\Rancheria Vene Rancheria\W & HW Feasibility Study\AutoCAD\Figures\Fig 6-2a.dwg DATE: 8/23/05

Figure 6-2
Lone Casino and Hotel Feasibility Study
Flow Diagram with Recycled Water for Alternative A

7.0 References

Applied Engineering and Geology, Inc. (2 March 2004). *Results of Soil and Mantle and Percolation Tests – Property: Ione Rancheria*. Lincoln, CA.

Applied Engineering and Geology, Inc. (20 October 2004). *Pumping Tests and Sustainability Analysis for Wells H1, M1, and M3, and Evaluation of Water Quality – Property: Ione Rancheria*. Lincoln, CA.

Crites and Tchobanoglous (1998). *Small and Decentralized Wastewater Management Systems*. New York, NY:McGraw-Hill.

Mancebo, G (14 February 2002). Telephone conversation with Gene Mancebo, Amador Water Agency.

Metclaf and Eddy (2003). *Wastewater Engineering, Fourth Edition*. New York, NY:McGraw Hill.

Appendix A

Full Tables 2-1 through 2-4, Estimated Wastewater Flows for Site
Layout Alternatives A through D

Table 2-1
Estimated Wastewater Flows for Site Layout Alternative A, Phase 1 and 2 (gpd)

	Square Footage (ft ²)	Quantity (each)	Units (each)	Frequency (uses/day)	Use Subtotal (units)	Flow/Unit (gpd/unit)	Flow (gpd)	Typical WEEKDAY Flows				Typical WEEKDAY Flows (gpd)	Typical WEEKEND Flows				Typical WEEKEND Flows (gpd)	AVERAGE Day Flows *				AVERAGE Day Flows * (gpd)
								A.M.		P.M.			A.M.		P.M.			A.M.		P.M.		
								(%)	(gpd)	(%)	(gpd)		(%)	(gpd)	(%)	(gpd)		(%)	(gpd)	(%)	(gpd)	
Casino																						
Slots	50,000	2,000 seats		12	24,000	4	96,000	40%	38,400	65%	62,400	50,400	75%	72,000	125%	120,000	96,000	50%	48,000	82%	78,857	63,429
Tables (40 tables @ 7 seats per table)	15,000	280 seats		12	3,360	4	13,440	40%	5,376	65%	8,736	7,056	75%	10,080	125%	16,800	13,440	50%	6,720	82%	11,040	8,880
Employees		1,412 employees		3	4,236	13	55,068	30%	16,520	50%	27,534	22,027	50%	27,534	75%	41,301	34,418	36%	19,667	57%	31,467	25,567
Restaurants																						
Buffet	20,000	250 seats		12	3,000	4	12,000	30%	3,600	50%	6,000	4,800	75%	9,000	100%	12,000	10,500	43%	5,143	64%	7,714	6,429
Restaurant #1 (Specialty)		100 seats		10	1,000	10	10,000	30%	3,000	50%	5,000	4,000	75%	7,500	100%	10,000	8,750	43%	4,286	64%	6,429	5,357
Coffee Bar		10 seats		12	120	3	360	30%	108	50%	180	144	75%	270	100%	360	315	43%	154	64%	231	193
Sports Bar		50 seats		12	600	3	1,800	30%	540	50%	900	720	75%	1,350	100%	1,800	1,575	43%	771	64%	1,157	964
Public & Miscellaneous Areas	15,000					0.0	0	30%	0	50%	0	0	50%	0	75%	0	0	36%	0	57%	0	0
Back of House (refer to employees)	20,000					0.2	4,000	30%	1,200	50%	2,000	1,600	50%	2,000	75%	3,000	2,500	36%	1,429	57%	2,286	1,857
Cooling Towers (Average Estimated Waste Flow)		1 LS					20,000	50%	10,000	100%	20,000	15,000	50%	10,000	100%	20,000	15,000	50%	10,000	100%	20,000	15,000
Parking		3,039 spaces				0.0	0	30%	0	50%	0	0	50%	0	75%	0	0	36%	0	57%	0	0
Hotel																						
Rooms	166,500	250 rooms		1	250	150	37,500	50%	18,750	50%	18,750	18,750	100%	37,500	100%	37,500	37,500	64%	24,107	64%	24,107	24,107
Event and Convention Center	30,000					0.2	6,000	30%	1,800	50%	3,000	2,400	50%	3,000	75%	4,500	3,750	36%	2,143	57%	3,429	2,786
Subtotal	316,500								99,294	gpd	154,500	gpd		180,234	gpd	267,261	gpd		122,420	gpd	186,717	gpd
Flow period duration per day (hours)									12	hours	12	hours		12	hours	12	hours		12	hours	12	hours
Period Flow									49,647	gpd	77,250	gpd		90,117	gpd	133,631	gpd		61,210	gpd	93,359	gpd
Subtotal Daily Flows											126,897	gpd	126,897			223,748	gpd	223,748			154,569	gpd
I&I									0%	0	gpd	0		0%	0	gpd	0		0%	0	gpd	0
Daily Flows									Weekday Flow		126,897	gpd	126,897	Weekend Flow		223,748	gpd	223,748	Average Day flow		154,569	gpd
Calculated Peaking Factor											1.0	1.0				1.76	1.76				1.22	1.22

*Average Day Flow = 5/7 Weekday + 2/7 Weekend

Peaking factors are back-calculated as an internal check only and are not used to calculated flows.

Instantaneous occupancy is used as an internal check only. It is only an estimated realtime snap shop of how many guests and employees may be in the facility at a given time.

Table 2-4
Estimated Wastewater Flows for Site Layout Alternative D (gpd)

	Square Footage (ft ²)	Quantity (each)	Units (each)	Frequency (uses/day)	Use Subtotal (units)	Flow/Unit (gpd/unit)	Flow (gpd)	Typical WEEKDAY Flows		Typical WEEKDAY Flows (gpd)	Typical WEEKEND Flows				Typical WEEKEND Flows (gpd)	AVERAGE Day Flows ^a				AVERAGE Day Flows ^a (gpd)			
								A.M.			P.M.		A.M.			P.M.		A.M.			P.M.		
								(%)	(gpd)		(%)	(gpd)	(%)	(gpd)		(%)	(gpd)	(%)	(gpd)		(%)	(gpd)	
Retail																							
Anchor Stores	42,625	0 seats				0.2	8,525	30%	2,558	50%	4,263	3410	50%	4,263	75%	6,394	5,328	36%	3,045	57%	4,871	3,958	
In Line Shops	80,625	0 seats				0.2	16,125	30%	4,838	50%	8,063	6450	50%	8,063	75%	12,094	10,078	36%	5,759	57%	9,214	7,487	
Employees		720 employees		3	2,160	13	28,080	30%	8,424	50%	14,040	11232	50%	14,040	75%	21,060	17,550	36%	10,029	57%	16,046	13,037	
Restaurants																							
Restaurant #1, Short Order		50 seats		10	500	4	2,000	30%	600	50%	1,000	800	75%	1,500	100%	2,000	1,750	43%	857	64%	1,286	1,071	
Restaurant #2, Conventional Sit Down		50 seats		6	300	10	3,000	30%	900	50%	1,500	1200	75%	2,250	100%	3,000	2,625	43%	1,286	64%	1,929	1,607	
Coffee Bar		10 seats		12	120	3	360	30%	108	50%	180	144	75%	270	100%	360	315	43%	154	64%	231	193	
Parking		650 spaces				2.0	1,300	30%	390	50%	650	520	50%	650	75%	975	813	36%	464	57%	743	604	
Subtotal	123,250								17,817	gpd	29,695	gpd		31,035	gpd	45,883	gpd		21,594	gpd	34,320	gpd	
Flow period duration per day (hours)									12	hours	12	hours		12	hours	12	hours		12	hours	12	hours	
Period Flow									8,909	gpd	14,848	gpd		15,518	gpd	22,941	gpd		10,797	gpd	17,160	gpd	
Subtotal Daily Flows											23,756	gpd	23,756			38,459	gpd	38,459			27,957	gpd	27,957
I&I									0%	0	gpd	0		0%	0	gpd	0			0%	0	gpd	0
Daily Flows									Weekday Flow		23,756	gpd	23,756	Weekend Flow		38,459	gpd	38,459	Average Day Flow		27,957	gpd	27,957
Calculated Peaking Factor									1.0		1.0			1.62		1.62			1.18		1.18		

^aAverage Day Flow = 5/7 Weekday + 2/7 Weekend

Peaking factors are back-calculated as an internal check only and are not used to calculate flows.

Instantaneous occupancy is used as an internal check only. It is only an estimated realtime snapshot of how many guests and employees may be in the facility at a given time.

Table 2-3
Estimated Wastewater Flows for Site Layout Alternative C, Phase 1 and 2 (gpd)

	Square Footage (ft ²)	Quantity (each)	Units (each)	Frequency (uses/day)	Use Subtotal (units)	Flow/Unit (gpd/unit)	Flow (gpd)	Typical WEEKDAY Flows				Typical WEEKDAY Flows (gpd)	Typical WEEKEND Flows				Typical WEEKEND Flows (gpd)	AVERAGE Day Flows ^a				AVERAGE Day Flows ^a (gpd)
								A.M.		P.M.			A.M.		P.M.			A.M.		P.M.		
								(%)	(gpd)	(%)	(gpd)		(%)	(gpd)	(%)	(gpd)		(%)	(gpd)	(%)	(gpd)	
Casino																						
Slots	25,000	1,000 seats		12	12,000	4	48,000	40%	19,200	65%	31,200	25,200	75%	36,000	125%	60,000	48,000	50%	24,000	82%	39,429	31,714
Tables (20 tables @ 7 seats per table)	7,500	140 seats		12	1,680	4	6,720	40%	2,688	65%	4,368	3,528	75%	5,040	125%	8,400	6,720	50%	3,360	82%	5,520	4,440
Employees		852 employees		3	2,556	13	33,228	30%	9,968	50%	16,614	13,291	50%	16,614	75%	24,921	20,768	36%	11,867	57%	18,987	15,427
Restaurants																						
Buffet		250 seats		12	3,000	4	12,000	30%	3,600	50%	6,000	4,800	75%	9,000	100%	12,000	10,500	43%	5,143	64%	7,714	6,429
Restaurant #1 (Specialty)		0 seats		10	0	10	0	30%	0	50%	0	0	75%	0	100%	0	0	43%	0	64%	0	0
Coffee Bar		0 seats		12	0	3	0	30%	0	50%	0	0	75%	0	100%	0	0	43%	0	64%	0	0
Sports Bar		50 seats		12	600	3	1,800	30%	540	50%	900	720	75%	1,350	100%	1,800	1,575	43%	771	64%	1,157	964
Public & Miscellaneous Areas	13,000						0.0	30%	0	50%	0	0	50%	0	75%	0	0	36%	0	57%	0	0
Back of House (refer to employees)	15,250						0.2	30%	915	50%	1,525	1,220	50%	1,525	75%	2,288	1,906	36%	1,089	57%	1,743	1,416
Cooling Towers (Average Estimated Waste Flow)		1 LS					20,000	50%	10,000	100%	20,000	15,000	50%	10,000	100%	20,000	15,000	50%	10,000	100%	20,000	15,000
Parking		1,579 spaces					0.0	30%	0	50%	0	0	50%	0	75%	0	0	36%	0	57%	0	0
Hotel																						
Rooms	0	0 rooms		1	0	150	0	50%	0	50%	0	0	100%	0	100%	0	0	64%	0	64%	0	0
Event and Convention Center	0						0.2	30%	0	50%	0	0	50%	0	75%	0	0	36%	0	57%	0	0
Subtotal	79,250							46,911	gpd	80,607	gpd		79,529	gpd	129,409	gpd		56,231	gpd	94,550	gpd	
Flow period duration per day (hours)				12	hours			12	hours	12	hours		12	hours	12	hours		12	hours	12	hours	
Period Flow								23,456	gpd	40,304	gpd		39,765	gpd	64,704	gpd		28,115	gpd	47,275	gpd	
Subtotal Daily Flows										63,759	gpd	63,759			104,469	gpd	104,469			75,391	gpd	75,391
I&I									0%	0	gpd	0		0%	0	gpd	0		0%	0	gpd	0
Daily Flows								Weekday Flow	63,759	gpd	63,759		Weekend Flow	104,469	gpd	104,469		Average Day flow	75,391	gpd	75,391	
Calculated Peaking Factor									1.0		1.0			1.64		1.64			1.18		1.18	

^aAverage Day Flow = 5/7 Weekday + 2/7 Weekend

Peaking factors are back-calculated as an internal check only and are not used to calculate flows.

Instantaneous occupancy is used as an internal check only. It is only an estimated realtime snapshot of how many guests and employees may be in the facility at a given time.

Appendix B

Pumping Tests and Sustainability Analysis for Wells H1, M1, and M3, and Evaluation of Water Quality

**PUMPING TESTS AND SUSTAINABILITY
ANALYSIS FOR WELLS H1, M1, AND M3, AND
EVALUATION OF WATER QUALITY**

PROPERTY:

**IONE BAND OF THE MIWOK INDIANS
CASINO AND HOTEL SITE**
SOUTH SIDE OF THE CITY OF PLYMOUTH
AMADOR COUNTY, CALIFORNIA

PREPARED FOR:

JOE BROADHEAD
ANALYTICAL ENVIRONMENTAL SERVICES
2021 N STREET, SUITE 200
SACRAMENTO, CALIFORNIA 95814

PREPARED BY:

APPLIED ENGINEERING AND GEOLOGY, INC.
578 E STREET • POST OFFICE BOX 247
LINCOLN, CALIFORNIA 95648
OFFICE 916.645.6014 • FAX 916.645.6098 • EMAIL aeg@psyber.com

OCTOBER 20, 2004

TABLE OF CONTENTS

1.0	INTRODUCTION	1
2.0	GENERAL SITE INFORMATION	1
2.1	Geology/Hydrogeology	1
3.0	GROUND WATER INVESTIGATION	6
3.1	Ground Water Pumping Test	6
3.1.1	Well Construction Details	6
3.1.2	Pump Details	7
3.1.3	Pump Testing Methods	8
3.1.4	Pumping Test Design	9
3.1.5	Measurement of Hydraulic Response	9
3.1.6	Measurement of Discharge Rate	9
3.1.7	Model Used	9
3.2	Pumping Test Results and Evaluation	9
3.2.1	Pumping Test Schedule	10
3.2.2	Pumping Tests Results	10
3.2.3	Aquifer Parameter Estimation	13
3.2.4	Long-Term Well Yield	13
3.3	Water Quality	15
4.0	DISCUSSION AND RECOMMENDATIONS	17
4.1	Discussion	17
4.2	Recommended Long Term Well Yield	18
5.0	STATEMENT OF LIABILITY	19

LIST OF FIGURES

1	Site Vicinity Map	2
2	Generalized Site Map	3
3	Watershed Map	5

LIST OF TABLES

3-1	Well Construction Details	7
3-2	Pump Installation Details	7
3-3	Testing Schedule	10
3-4	Testing Durations, Discharge Rates, and Drawdowns	11
3-5	Estimated Values of Hydraulic Conductivity (K) and Transmissivity (T) Based on Recovery Test Data	13
3-6	Calculation of Long-Term Well Yield	14
3-7	Results of Ground Water Samples Analyzed for CAM 17 Metals	15
3-8	Results of Ground Water Samples Analyzed for General Water Quality	16
3-9	Results of Water Samples Collected and Analyzed for Total Coliforms and E. Coli	17
4-1	Recommended Long-Term Well Yields	18

LIST OF APPENDICES

Appendix A	DWR Well Logs for Project Wells
Appendix B	Pumping Test Data
Appendix C	Pumping Test Graphical Results
Appendix D	Calculation of Long-Term Well Yield
Appendix E	Analytical Laboratory Report

1.0 INTRODUCTION

At the request of Analytical Environmental Services (AES), Applied Engineering and Geology, Inc. (AEG) has prepared this *Pumping Tests and Sustainability Analysis for Wells H1, M1, and M3, and Evaluation of Water Quality* (Report) to document the pumping tests conducted by AEG at the Ione Band of Miwok Indians Casino and Hotel Site (Project Site). The Project scope of work included performing a series of pumping tests on wells M1, M3, and H1. The objective of the pumping tests was to determine the recommended long-term yield for these wells. Wells M2 and M4 were each utilized as an observation well for certain tests, but were not included in the scope of work to determine long-term yield.

Work performed and included in this document is as follows:

- Pumping test and sustainable yield evaluation for wells H1, M1, and M3;
- Evaluation of DWR Well logs for wells within a two mile radius of the Project Site; and,
- Collection of water samples from wells H1, M1, and M3 for water quality analyses.

2.0 GENERAL SITE INFORMATION

The Ione Rancheria (Project Site) is located on the east side of Highway 49 at the southern limits of the City of Plymouth, Amador County, California (see **Figure 1**). A general layout of the Project Site and the locations of all wells tested are shown on **Figure 2**.

2.1 Geology/Hydrogeology

This Project Site is on the western side of the New Melones Fault Zone and is approximately 2.5 miles east of the Bear Mountain Fault Zone. The onsite geologic materials consist of greenstone along the western edge and Upper Jurassic marine sedimentary and metasedimentary rocks of the Mariposa Formation. These sedimentary and metasedimentary rocks are primarily weathered shale and slate with minor thin beds of sandstone. The soil layer is very thin over most of the Project Site, ranging from less than three inches to a maximum of approximately two feet.

During the placement of backhoe test pits at the western side of the Project Site during the fall of 2003, no ground water was encountered by any of the excavation activities. However, while conducting an inspection of the gullies on the western portion of the Project Site during December 2003, numerous springs were observed. The location of these springs was reported in AEG's *Results of Soil Mantle And Percolation Tests*, dated March 2, 2004.

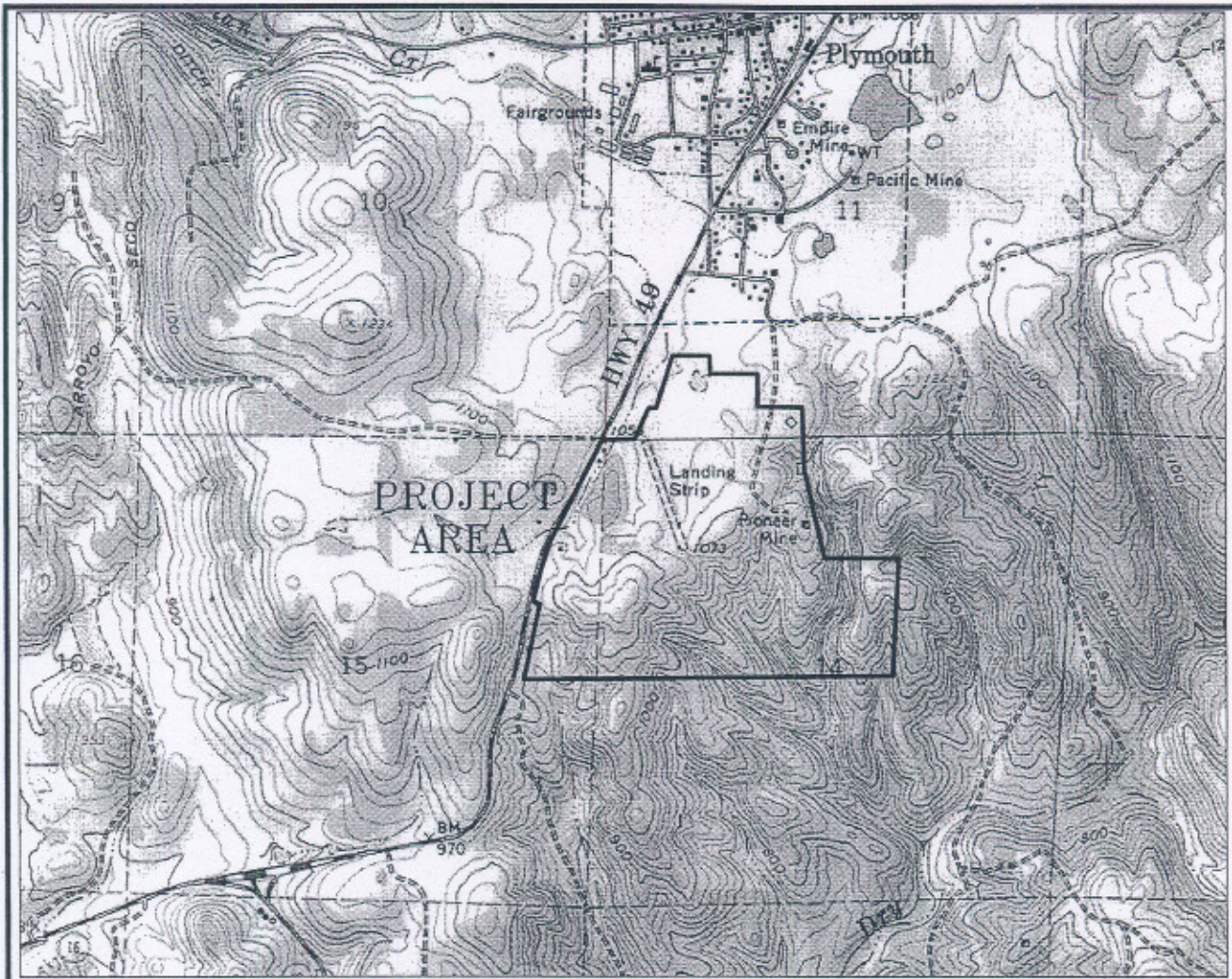

TN MN
15°

0 1000 FEET 0 500 1000 METERS

Printed from TOPO! ©2000 National Geographic Holdings (www.topo.com)



1000' 0' 1000' 2000'

SCALE 1"=2000' +/-
REVISED AUGUST 16, 2004

S:\AEG DOCUMENTS\IONE\IONE FIG. 1.DWG(22)

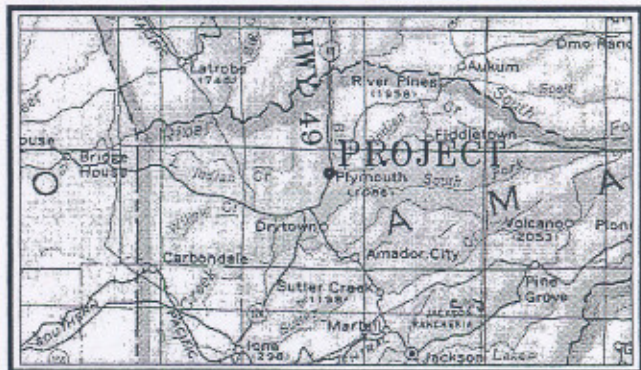

NOT TO SCALE

A PPLIED
E NGINEERING AND
G EOLOGY, INC.

P.O. BOX 247, LINCOLN, CA 95648
(916) 645-6014 (916) 645-6098 FAX

SITE VICINITY MAP
IONE CASINO SITE
PLYMOUTH, AMADOR COUNTY, CALIFORNIA

FIGURE 1

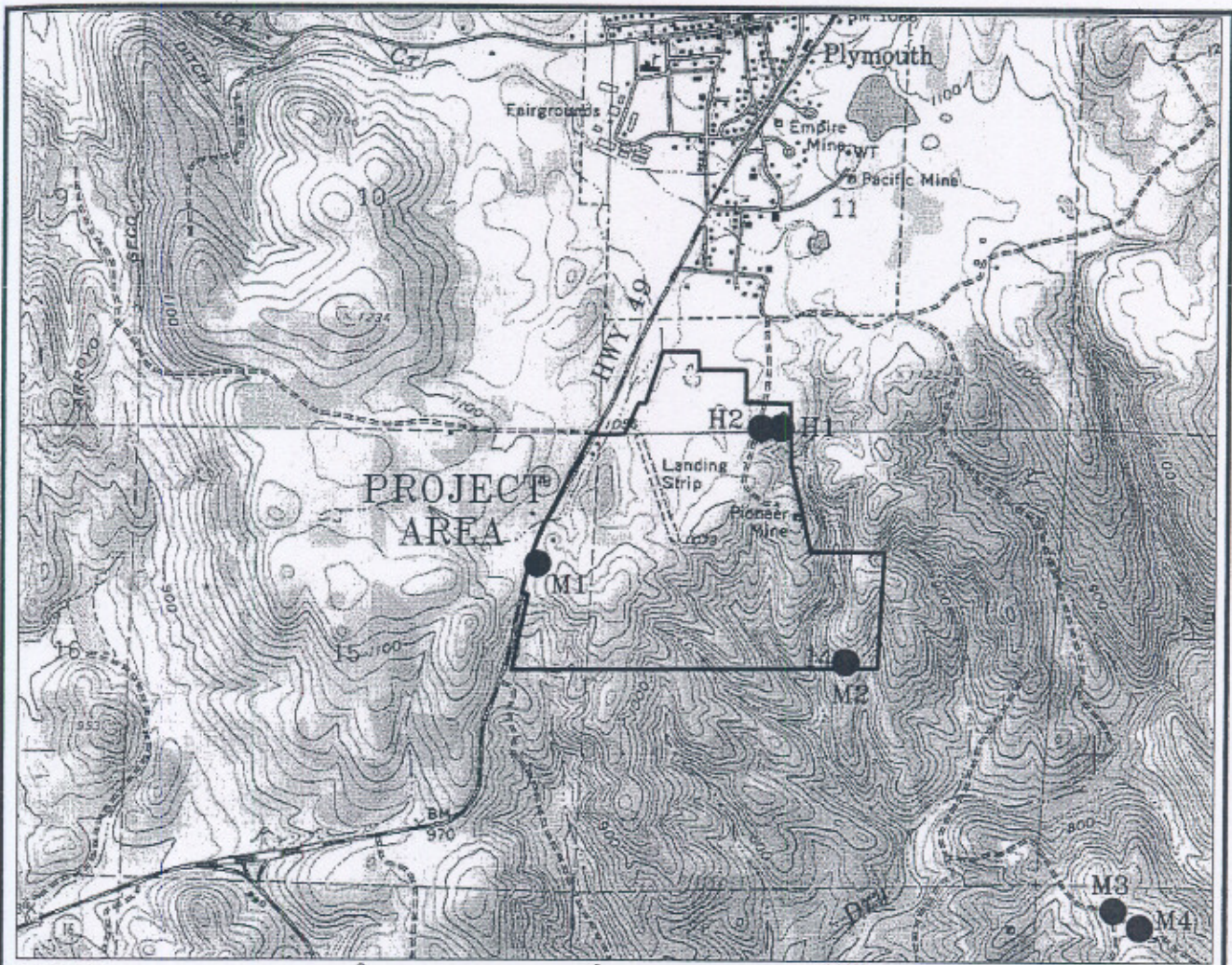

TN * /MN
15°

0 1000 FEET 0 500 1000 METERS

Printed from TOPO! ©2000 National Geographic Holdings (www.topo.com)

LEGEND

M2 ● APPROXIMATE LOCATION OF DOMESTIC WELLS AND CISTERN LOCATED BY AEG

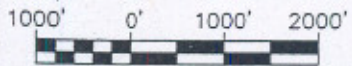

SCALE 1"=2000' +/-

REVISED AUGUST 16, 2004

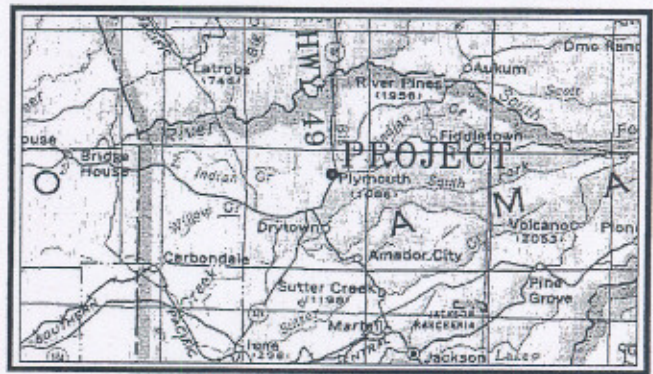

NOT TO SCALE

A PPLIED
E NGINEERING AND
G EOLOGY, INC.

P.O. BOX 247, LINCOLN, CA 95648
(916) 645-6014 (916) 645-6098 FAX

**GENERALIZED SITE MAP
IONE CASINO SITE
PLYMOUTH, AMADOR COUNTY, CALIFORNIA**

FIGURE 2

Observed surface water features on the Project Site include several springs in the drainages within the southwest quadrant; a pond in the extreme southwest corner, along Highway 49; a seasonal stream (Dry Creek) and its tributaries; a slough along the western boundary (Highway 49); and a small stock pond in the open field north of the abandoned runway.

Based on readings collected by AEG in the field, depth to static ground water in the wells within the Project boundaries ranged from approximately 30 feet to 75 feet below ground surface (bgs).

As shown by **Figure 3**, the drainage basin that includes M1 is quite small, and encompasses approximately 1,421 acres (2.2 square miles). The drainage basin that includes wells H1, H2, M2, M3, and M4 is a long and narrow basin that extends approximately 14 miles to the east, and encompasses approximately 35.5 square miles.

Department of Water Resources (DWR) Well Completion Reports (DWR Well Logs) for all water supply wells within a two mile radius of the Project Site were requested from the State of California, Department of Water Resources. Once the DWR Well Logs were received, a simple evaluation of the data was performed. The wells were plotted based on the data provided by the DWR Wells Logs. However, the descriptions given by most drillers to locate the well is very general so only a few were plotted with an exact location. Since most of the wells were only plotted to the closest 40 acre parcel, or to the nearest section (640 acres). A copy of the plot was not included in this report.

Based on the DWR Well Logs, it would appear that there are approximately 27 domestic water producing wells located within the smaller drainage basin that encompasses most of the Town of Plymouth and well M1. These wells vary in depth from approximately 80 feet to 800 feet, with static water levels ranging from 14 feet to just over 200 feet. The wells appear to equally dispersed throughout the drainage basin. The materials encountered vary from slate and shale to greenstone and granitics. With a few exceptions, the higher producing wells appear to be located within granitic material. There are two wells located within Section 11 (the Town of Plymouth) and one in Section 15 (west of the Project Area) that are reported to produce water at a rate greater than 200 gpm.

There are approximately 96 domestic water producing wells within the western end of the watershed that contains wells M2, M3, M4, and H1. The majority of the wells are located on the western side of the Town of Plymouth in Section 12, Township 7N, Range 6E and are within granitic material. These 96 wells vary in total depth from just under 100 feet to over 800 feet, with static water levels ranging from 40 feet to 500 feet below ground surface. Approximately 50 percent of the wells in Section 12 are reported to produce greater than 50 gpm.

The first part of the document discusses the importance of maintaining accurate records of all transactions. It emphasizes that every entry, no matter how small, should be recorded to ensure the integrity of the financial statements. The second part covers the various methods used to record transactions, including the double-entry system and the use of journals and ledgers. It also discusses the importance of regular reconciliations to identify and correct any errors. The third part of the document deals with the classification of transactions into different accounts, such as assets, liabilities, and equity. It explains how these transactions affect the accounting equation and how they are recorded in the general ledger. The final part of the document discusses the preparation of financial statements, including the balance sheet, income statement, and statement of cash flows. It provides a step-by-step guide to the process, from gathering the data to the final presentation of the statements.

Based on DWR Well Logs, there are approximately 20 domestic wells within 2000 feet of the Project Area. Fourteen of these wells are located within the smaller drainage basin, and six are located within the larger drainage basin. Twelve of the wells (eight within the smaller basin) are reported to produce less than 15 gpm. Four of the wells (three within the smaller basin) are reported to produce between 16 and 50 gpm. And, four of the wells (three within the smaller basin) were reported to produce greater than 51 gpm. With the exception of H1, the three higher producing wells (51+ gpm) are all located west of the Project Area.

3.0 GROUND WATER INVESTIGATION

3.1 Ground Water Pumping Test

3.1.1 Well Construction Details

Information obtained during the drilling and installation of wells M1 through M4 and well H1 was provided on the DWR Well Logs for the onsite wells. The DWR Well Logs, which are presented in **Appendix A**, provide information relating to lithology encountered during drilling, water strikes, static water level, airlift yield, total depth, and well construction details. Although the information is general, it does provide valuable background information and insight into ground water occurrence. Based on a review of the reports, the following is evident.

- The geology is characterized by shale and slate. The drilling report for well H1 indicates 40 feet of overburden. No overburden is reported in the other well reports. However, results of previous field studies indicate that a thin unsaturated soil layer covers most of the Project Site explored by AEG during previous studies and generally ranges from less than three inches to a maximum of approximately two feet;
- The wells were drilled using the air rotary method to a diameter of 11 inches. They were completed with 6-inch diameter surface casing (grouted in place) and a 4-inch diameter PVC liner that was perforated from the primary water strike to total depth. Well H1 is an exception and was completed as an open hole below the surface casing;
- Airlift yield sustained over a four-hour testing period ranged from 15 to 150 gallons per minute (gpm);
- The primary water strikes occurred from depths of 180 to 600 feet below ground surface (bgs) in bedrock. Due to the low hydraulic conductivity (K) and storativity (S) generally associated with shale and slate, it is apparent that the water is stored and transmitted by fracture flow; and,
- Static water level measured after well completion ranged from 30 to 75 feet bgs, which is well above the water strikes and therefore indicative of confined groundwater conditions.

Well construction details of wells M1, M3, M4 and H1 are summarized in Table 3-1.

Well	Date Drilled	Total Depth (bgs)	Surface Casing ¹	Blank Casing	Screened Interval (bgs)	Depth to Water Strike (bgs)	Static Water Level ² (bgs)	Airlift Yield ³ (gpm)
M1	8/10/01	620	6" PVC to 55'	4" PVC liner 0 - 540'	540 - 620	600	60	15
M3	1/16/04	220	6" PVC to 60'	4" PVC liner 0 - 180'	180 - 220	180	30	70
M4	2/20/04	340	6" PVC to 60'	4" PVC liner 0 - 280'	280 - 340	200 (5 gpm) 240 (10 gpm)	45	15
H1	11/3/77	223	6" PVC to 80'	None	Open hole	105 - 107 200 - 205	75	150

¹ 6" surface casing was grouted in place.

² Static water level as shown on DWR Well Logs (except for H1, which was measured in the field)

³ Airlift yield obtained from Well Completion Reports, measured prior to well installation. Test duration was four hours.

bgs = below ground surface (in feet).

gpm = gallons per minute

3.1.2 Pump Details

Shown in Table 3-2 are the details associated with installation of the test pumps in each of the pumped wells.

Well	Total Depth (bgs)	Screened Interval (bgs)	Depth to Water Strike (bgs)	Static Water Level ¹ (bgs)	Pump Size (Hp)	Depth to Top of Pump (feet)
M1	620	540 - 620	600	53	5	600
M3	220	180 - 220	180	37	7.5	200

¹ Static water level as measured by AEG in the field.

bgs = below ground surface (in feet).

gpm = gallons per minute

3.1.3 Pump Testing Methods

Four types of pumping tests were utilized to obtain information necessary to complete the proposed scope of work. These tests included:

- Step-drawdown tests;
- Constant rate tests;
- Constant yield and drawdown tests; and,
- Recovery tests.

Each type of test is further defined as follows:

Step-Drawdown Tests

Step-drawdown tests were performed to evaluate drawdown behavior (in the pumped well) in response to pumping and identify the optimum yield for the constant rate test. The step-drawdown test involves pumping the well at variable discharge rates, increasing the discharge rate in a step-wise fashion, and measuring discharge rate and water level response for the test duration.

Constant Rate Tests

Constant rate tests were conducted to assess well response to pumping at a constant discharge rate. The pumping tests involved measurement of water levels in the pumping well and observation wells during pumping, and measurement of the discharge rate.

Constant Yield and Drawdown Tests

The constant yield and drawdown tests were generally conducted in instances where water levels did not stabilize within 48 to 72 hours of constant rate pumping. The tests were performed by pumping at a relatively high discharge rate, and then subsequently reducing the discharge rate until the drawdown stabilized. Pumping at the adjusted rate was continued to ensure that stabilization was maintained. Water level in the pumped well and discharge rates were recorded for the duration of the test.

Recovery Tests

Recovery tests involve the measurement of water levels in the pumping and observation wells following the cessation of pumping. Recovery test data collected following constant rate tests were used to estimate hydraulic conductivity (K) and transmissivity (T) and to assess aquifer performance.

3.1.4 Pumping Test Design

Actual test duration was determined in the field based on real-time reviews of the well response to pumping. The wells were tested individually and allowed to recover prior to the start of subsequent tests to avoid difficulties in data interpretation due to potential well interference. The testing of well M3 was an exception due to the slow recovery characteristics of the well.

3.1.5 Measurement of Hydraulic Response

The constant rate test conducted in well M3 included water level measurements in observation wells M2, M4, and H1 to assess the potential for hydraulic communication between the wells. Observation wells were not included for any of the other pumping tests. Water levels were measured manually using an electronic water level indicator. For each measurement, date, time, and depth to water from the top of the well casing (to nearest 1/100 foot) were recorded on field forms. This data was then tabulated for evaluation. Copies of this tabulated data is included in **Appendix B**.

3.1.6 Measurement of Discharge Rate

A real time and cumulative flow meter was used to measure the discharge rate for the pumping tests performed in wells M1 and M3. Due to the high discharge rate during the pumping test at well H1, it was not possible to use a real time and cumulative flow meter since the meters were only calibrated to record flows from five to 50 gpm. Instead, the discharge rate during the pumping test at well H1 was calculated by timing how long it took to discharge five gallons.

3.1.7 Model Used

For the purposes of this report at this Project Site, we will look at the fractured rock above any regional fault zone as an *Equivalent Porous Medium Model*. All techniques used with porous media apply, including evaluating pumping test data to obtain transmissivity, specific capacity, specific yield, etc., drawing of flow nets, and determining capture zones. The *Equivalent Porous Medium Model* is valid when there is a sufficiently high fracture density, which does exist at this Project Site.

3.2 Pumping Test Results and Evaluation

This section presents the pumping test results and analysis. The results include time series water level and discharge rate data. Water level and production rate data were interpreted to develop estimates of aquifer parameters (K and T) and long-term well yield, and to assess the potential for hydraulic communicating between wells.

3.2.1 Pumping Test Schedule

The pumping test program was conducted over a period of nine months, from December 2003 through August 2004. The start and end dates and times and test durations for each test, including the recovery periods, are summarized in **Table 3-3**.

TABLE 3-3				
Testing Schedule				
Well	Test	Start Date / Time	End Date / Time	Duration (hours)
Step-Drawdown				
M3	Pumping	07/06/04 14:46	07/06/04 19:00	4.2
	Recovery	07/06/04 19:00	07/07/04 08:30	13.5
Constant Rate				
H1	Pumping	12/02/03 15:00	12/09/03 13:08	166.1
	Recovery	12/09/03 13:12	01/08/04 08:18	715.1
M3	Pumping	07/07/04 08:30	07/12/04 11:41	123.2
	Recovery	07/12/04 11:41	07/31/04 09:51	454.2
Constant Yield and Drawdown				
M1	Pumping	12/13/03 13:00	12/16/03 08:22	67.4
	Recovery	12/16/03 08:22	12/16/03 17:00	8.6
M3	Pumping	07/31/04 09:51	08/04/04 12:54	99.0

3.2.2 Pumping Tests Results

The discharge rates used for the constant rate and constant yield and drawdown tests were selected based on airlift yield at the time of drilling for wells M1 and H1. A combination of airlift yield and step-drawdown test results were used to select optimum discharge rates for well M3. A summary of airlift yields (obtained from the DWR Well Logs), test durations, discharge rates, and drawdown at the end of the tests are summarized in **Table 3-4**.

Well	Airlift Yield ¹ (gpm)	Test	Duration (days)	Discharge Rate (gpm)	Drawdown at Test End (feet)
M1	15	Constant Yield and Drawdown	2.8	Initially 37.9 gpm, reduced to 17 gpm	Stabilized at 480 feet
M3	75	Step Drawdown	0.2	Step 1: 50 gpm for 6 min Step 2: 60 gpm for 188 min Step 3: 70 gpm for 60 min	13.53
		Constant Rate	5.1	75	35.71
		Constant Yield and Drawdown	4.1	Variable, but ~ 50 to 53 gpm for last 25 hours	36.72 ²
H-1	150	Constant Rate	6.9	60	44.48

¹ Airlift yield obtained from DWR Well Logs, measured prior to well installation. Test duration was four hours.

² Well had not completely recovered from prior pumping. During the constant yield testing, there was an additional drawdown of 20.77 feet for a total drawdown of 36.72 from static water level.

gpm = gallons per minute

The results of the pumping tests are summarized in tabular format in **Appendix B** and are graphically illustrated in **Appendix C**. The plots present drawdown (in feet) versus time (in minutes) using a normal linear scale. A discussion of test results for individual wells is presented in the following sections. These results form the basis of the calculations of long-term yield presented in **Section 3.2.4**.

Well M1

The constant yield and drawdown test conducted at well M1 resulted in stabilized drawdown of approximately 480 feet for 40.9 hours at a discharge rate of approximately 17 gpm. Water levels recovered relatively rapidly following cessation of pumping. A residual drawdown of 14.8 feet remained after 532 minutes of recovery.

Well M3

During the 70 gpm constant rate test conducted at well M3, it appeared that water levels were beginning to stabilize at a drawdown of approximately 23 feet. However, at approximately 1,800 minutes, a boundary condition was encountered that increased the slope of the drawdown curve. The increase in slope is evident in the plot of drawdown versus time presented in **Appendix C**. The boundary could be attributed to a low hydraulic conductivity (K) fault or a change in lithology, or potentially to a decrease in transmissivity as the fractures that store and transmit water in the confined unit pinch out laterally or become less interconnected. This condition could limit the long-term well yield unless additional sources of recharge are encountered as the radius of influence extends outward under a prolonged pumping scenario. The long-term yield calculations presented in **Section 3.2.4** attempt to address this condition and assume that additional sources of recharge are encountered as the radius of influence extends outward.

The constant rate pumping test results indicate that there is no hydraulic connection between well M3 and wells M4 and H1. Although well M2 does display somewhat of a declining trend during the constant rate test conducted at well M3, it appears likely that this is attributable to natural background declines that are expected in the dry season. A plot of the drawdown at wells M2 and M3 is included in the M3 section of **Appendix C**.

As illustrated on the recovery test plot provided in **Appendix C**, water levels recovered after the constant rate test from over 35 feet of drawdown to approximately 17 feet (residual drawdown) after 214 hours. The recovery plot developed to determine K and T is also included in **Appendix C**. The plot includes t/t' (time since start of pumping/time since pumping stopped) along the x axis and residual drawdown on the y axis. The slow recovery and the shape of the recovery curve (straight line plots to left of the origin [$t/t' = 1$] of the diagram) indicates incomplete recovery due to the limited extent of the aquifer.

The constant yield and drawdown test revealed a high specific capacity with relatively little drawdown. However, drawdown did not stabilize at a discharge rate of 51 gpm within the testing period. The long-term yield calculations are presented in **Section 3.2.4**.

Well H1

The 60 gpm constant rate test revealed a boundary condition at approximately 2,700 minutes that increased the slope of the drawdown curve. The increase in slope is evident in the plot of drawdown versus time presented in **Appendix C**. The boundary appears to be attributed to dewatering of an upper water strike that was reported in the well completion report at 105 to 107 feet bgs. This condition could affect long-term well performance as water from the upper water strike cascades into the well and aerates the water above the pump. The long-term yield calculations are presented in **Section 3.2.4**.

3.2.3 Aquifer Parameter Estimation

Water level data obtained during the recovery tests conducted following constant rate tests (wells M3 and H1) were evaluated to estimate aquifer parameters (K and T). The analysis was conducted using computer software developed by Waterloo Hydrogeologic titled AquiferTest, Version 2.5. Data input requirements for Aquifer Test include water level data, aquifer thickness, screen interval, discharge rate, and duration of the pumping phase.

The water level response in the monitoring wells is indicative of confined groundwater conditions. Static water levels well above the depth to the first water strike (recorded on the DWR Well Logs) supports this interpretation. Therefore, the data were analyzed using the Theis and Jacob Recovery method.

The results of the aquifer parameter estimation are presented in **Table 3-5**. Graphical representations of the analyses are presented in **Appendix C**. The results indicate K values that range from 4.3 to 0.65 feet per day (feet/day), which is consistent with the range of values typically associated with fractured shale and slate.

Well	Aquifer Thickness ¹	Hydraulic Conductivity (K)		Transmissivity (T)	
		(feet/day)	(cm/sec)	(feet ² /day)	(cm ² /sec)
M3	40	4.3	1.5 x 10 ⁻³	171	1.8
H1	20	6.5 x 10 ⁻¹	2.3 x 10 ⁻⁴	13	1.4 x 10 ⁻¹

¹ Aquifer thickness estimated as the well depth minus depth to the main water strike (from DWR Well Logs).
 cm/sec = centimeters per second
 cm²/sec = centimeters squared per second

3.2.4 Long-Term Well Yield

The long-term well yield in the context of this report is the rate at which water can be sustainably extracted from a well without undesired reductions in yield. Water quality data and assessments are presented in **Section 3.3** and are not considered further in this assessment of yield.

Long-term well yield, also referred to as "safe well yield" or "perennial well yield", requires the estimation of long term well capacity based on the results of relatively short-term pumping tests. The methodology used for this project is as follows:

- Step 1: Extrapolate drawdown assuming 200 days of continuous pumping. For the constant yield and drawdown tests, the extrapolated drawdown generally approximates the drawdown at the end of the test.

Step 2: Calculate the specific capacity (gpm/ft) [discharge rate (gpm) divided by drawdown (feet)] at 200 days. The 200 days of continuous pumping represents a period where groundwater recharge is at a minimum. It assumes that this minimum recharge period will be followed by the annual recharge period in winter and spring as increased precipitation and snowmelt occurs;

Step 3: Calculate total available drawdown (feet), as the depth to top of the first water strike (or top of well screen) minus the static (non pumping) water level. This is the maximum head that could potentially contribute to well yield;

Step 4: Calculate safe available drawdown, which is the allowable drawdown in the well for pumping. Safe available yield is calculated as the total available drawdown times a safety factor to account for a position for the pump, drought and seasonal water level declines, and future drops in well efficiency during operation. The safety factor is selected based on a qualitative review of recovery data; and,

Step 5: Calculate long-term well yield (gpm) as:

$$\text{Specific capacity at 200 days (gpm/foot)} \times \text{safe available drawdown (feet)}$$

The results of these calculations are summarized in **Table 3-6**. Individual calculation sheets are presented in **Appendix D**.

Well	Step 1 Drawdown extrapolated to 200 days (feet)	Step 2 Specific capacity at 200 days (gpm/foot)	Step 3 Total available drawdown (feet)	Step 4 Safe available drawdown (feet)	Step 5 Long-term yield ¹ (gpm)
M1	480.4	0.0354	487.3	341.11	12.1
M3	50	1.0200	137.6	41.3	42.1
H1	105	0.5714	118.8	71.3	40.7

¹ Due to the difficulties of accurately predicting the behavior of low storativity fractured bedrock aquifers during long-term pumping, these yields represent the upper limits that may be sustained. Refer to the discussion in Section 4.2 for the range of recommended long-term yields.

gpm = gallons per minute.

3.3 Water Quality

Water samples were collected from each of the pumped wells. Samples collected from M1 and H1 were collected on October 29, 2003. Samples collected from M3 were collected on July 12, 2004. These samples were analyzed for CAM 17 Metals, Conventional Chemistry Parameters, and Microbiological Parameters. Copies of the certified analytical laboratory reports are included in Appendix E. Results have been tabulated in Tables 3-7 through 3-9.

Analyte	M1	M3	H1
Arsenic	<5.0	<5.0	<5.0
Lead	<5.0	<5.0	<5.0
Selenium	<5.0	<5.0	<5.0
Thallium	<10	<10	<10
Antimony	<50	<50	<50
Barium	50	<20	39
Beryllium	<5.0	<5.0	<5.0
Cadmium	<10	<10	<10
Cobalt	<20	<20	<20
Chromium	<20	<20	<20
Copper	440	<20	<20
Molybdenum	<20	<20	<20
Nickel	<20	<20	<20
Silver	<10	<10	<10
Vanadium	<20	<20	<20
Zinc	60	<20	<20
Mercury	<0.20	<0.20	<0.20

TABLE 3-8
 Results of Ground Water Samples Analyzed for General Water Quality
 All Results in Parts Per Billion (ppb)

Analyte	M1	M3	H1
Total Alkalinity	180	220	630
Bicarbonate as CaCO ₃	180	220	630
Carbonate as CaCO ₃	<5.0	<5.0	<5.0
Hydroxide as CaCO ₃	<5.0	<5.0	<5.0
Chloride	7.0	12	26
Fluoride	0.34	0.21	0.24
Nitrate as NO ₃	<2.0	<2.0	<2.0
Sulfate as SO ₄	2.2	60	230
Total Sulfides ¹	33,000	- - -	- - -
Total Sulfides ²	<50	- - -	- - -
MBAS	<0.10	<0.10	<0.10
Specific Conductance	340	480	1400
Calcium	32	60	170
Magnesium	18	32	110
Potassium	3.4	<1.0	1.5
Sodium	23	11	30
Hardness as CaCO ₃	160	280	860
pH	8.00	6.90	7.20
Total Dissolved Solids (TDS)	200	360	910

- - - = Not analyzed for
¹ Sample collected during pumping test
² Sample collected after pumping test was complete, but before water level in well had recovered.

Sample Number	Total Coliforms	E. Coli
M1	Absent	Absent
M3	Absent	Absent
H1	Absent	Absent

4.0 DISCUSSION AND RECOMMENDATIONS

4.1 Discussion

The explored Project Site geology is characterized by a generally thin layer of overburden underlain by weathered bedrock consisting of shale and slate. Groundwater at the Project Site primarily occurs under confined conditions at depth in the fractured bedrock zones. The upper portions of the bedrock appear to have low hydraulic conductivity (K), presumably due to the lack of fracturing, and therefore represent a confining layer (aquitar) for the underlying confined unit. Due to the low K and S values typically associated with unfractured shale and slate, the groundwater yield of the confined unit is likely attributed to the ability of interconnected fractures to store and transmit groundwater.

The pumping test results indicate that there is no hydraulic communication between well M3 and wells M4 and H1. Although well M2 does display somewhat of a declining trend during the constant rate test conducted at well M3, it appears likely that this is attributable to natural background declines that are expected in the dry season. The test results also provided estimates of important hydraulic parameters for the confined bedrock unit. The estimates are consistent with the ranges typically encountered in the fractured shale and slate that comprise the confined unit.

4.2 Recommended Long Term Well Yield

The long-term well yields calculated and discussed in Section 3.2.4 are based on aquifer response to a relatively short period of pumping. Drawdown is extrapolated to 200 days to allow sufficient time for recharge to stabilize drawdown and improve well performance. This approach assumes that sufficient precipitation will occur and that a significant percentage of recharge will reach the aquifer. It also assumes that the interconnected fracture network extends beyond the radius of influence created during the test, and that these fractures have sufficient storage to produce sustainable yields. However, these conditions may not be realized. Recharge may be limited by the thick sequence of relatively low K slate and shale aquitard or recharge may be slow due to distant recharge areas. The fractures that store and transmit water in the confined unit may pinch out laterally or become less interconnected, effectively reducing aquifer transmissivity and limiting well yield. Hydraulic barriers not reached during the testing period (i.e. outside the radius of influence created during the test) may exist, caused by changes in lithology or low K faults, and limit the long-term yield.

To address these remaining degrees of uncertainty inherent in the calculation of long-term well yield in fractured bedrock with low primary porosity and storativity, the calculation and use of a range of recommended long-term well yields is required. A range of recommended long-term well yields was developed based on test results and is presented in Table 4-1. The upper limit is the long-term well yields provided in Section 3.2.4. The lower limit is established as 70% of the upper limit. The recommended long term well yield presented in Table 4-1 are best estimates of future well performance. It is recommended that actual long term yield be accurately determined in the first year of production by regularly monitoring water level response to pumping. During this period and based on actual well performance, the need for additional wells can be assessed to meet the required water demands.

Well	Lower Limit (gpm)	Upper Limit (gpm)	Recommended Long-Term Well Yields (gpm)
M1	8.5	12.1	10
M3	29.5	42.1	36
H1	28.5	40.7	35
Total Recommended Yield	68.9	98.4	81

gpm = gallons per minute

--- = Low capacity well (less than five gpm sustainable yield). Use not recommended.

5.0 STATEMENT OF LIABILITY

This *Pumping Tests and Sustainability Analysis for Wells H1, M1, and M3, and Evaluation of Water Quality* (Report) was prepared by Applied Engineering and Geology, Inc. (AEG), at the request of Analytical Environmental Services (Client), using the degree of care and skill ordinarily exercised, under similar circumstances, by reputable engineers, geologists, and scientists practicing in this or similar localities in California at the time this Report was prepared. No other warranty, expressed or implied, is made as to the information and professional advice included in this Report. This Report was written to document testing activities related to estimating the long-term yield of water from certain wells at the Site based on a limited number of observation points and limited duration tests. Further investigation, testing, and data analysis can reduce the inherent uncertainties associated with this type of testing. This Report is based on factual information obtained from Analytical Environmental Services, and others, that has been assumed to be correct, accurate and complete. Applied Engineering and Geology, Inc. does not guarantee the correctness, accuracy, or completeness of those data.

This Report and the data within has not been prepared for use by other parties or uses other than those for which it was intended, and may not contain sufficient information for the purposes of other parties or other uses.

This Report or any part thereof may not be reproduced in any form without written permission from Applied Engineering and Geology, Inc., its Principals, or agents.

Should you have any questions regarding the content of this report, please contact Earl Stephens at 916.645.6014.

Sincerely,

APPLIED ENGINEERING AND GEOLOGY, INC.

DOULOS ENVIRONMENTAL, INC.

Earl Stephens RCE 45335
Principal Engineer



Hal Hansen RG 6697
Principal Geologist

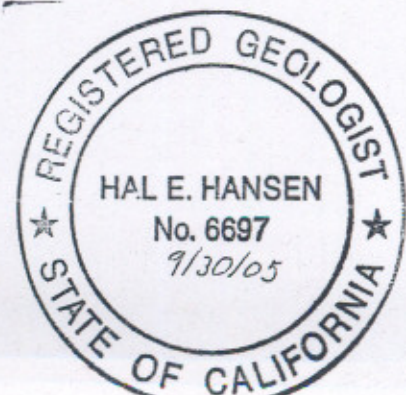

APPENDIX A

DWR Well Logs for Project Wells

TRIPPLICATE
Owner's Copy

STATE OF CALIFORNIA
WELL COMPLETION REPORT
Refer to Instruction Pamphlet

OWNER USE ONLY - DO NOT FILL IN

STATE WELL NO./STATION NO.

LATITUDE LONGITUDE

APN/TRS/OTHER

Page 1 of 1
Owner's Well No. 1
Date Work Began 8-7-06 Ended 8-10-07 No. 762275
Local Permit Agency AMADOR COUNTY ENVIRONMENTAL HEALTH DEPT.
Permit No. W02130 Permit Date 6-28-07

GEOLOGIC LOG

ORIENTATION () VERTICAL HORIZONTAL ANGLE _____ (SPECIFY)

DRILLING METHOD Air Rotary FLUID _____

DEPTH FROM SURFACE

FL	TO	FL	DESCRIPTION
0	100		Black Slate
100	540		Black Slate
540	620		Serpentine

Describe material, grain size, color, etc.

WELL OWNER Name RONALD MATULICH

Mailing Address 7400 HWY. 16
PLYMOUTH, CA. 95669

WELL LOCATION Address HWY. 49, So. End of Plymouth City Lim
City PLYMOUTH
County AMADOR

APN Book 008 Page 110 Parcel 009-501

Township _____ Range _____ Section _____

Latitude _____ NORTH Longitude _____

Actual water production depends upon hydrogeological conditions beyond the control of Contractor, and which are subject to dramatic changes in short periods of time. Therefore, Contractor does not warrant the continued production of any quantity or quality of water observed or reported at any stage of or at the conclusion of the project.

LOCATION SKETCH

WEST EAST

ACTIVITY ()

NEW WELL

MODIFICATION/REPAIR

Deepen

Other (Specify) _____

DESTROY (Describe Procedures and Method Under "GEOLOGIC LOG")

PLANNED USES ()

WATER SUPPLY

Domestic Public

Irrigation Incult

MONITORING _____

TEST WELL _____

CATHODIC PROTECTION _____

HEAT EXCHANGE _____

DIRECT PUSH _____

INJECTION _____

VAPOR EXTRACTION _____

SPARGING _____

REMEDIATION _____

OTHER (SPECIFY) _____

Illustrate or Describe Distance of Well from Roads, Buildings, Fences, Acres, etc., and attach a map. Use additional paper if necessary. PLEASE BE ACCURATE & COMPLETE.

WATER LEVEL & YIELD OF COMPLETED WELL

DEPTH TO FIRST WATER 600 (FL) BELOW SURFACE

DEPTH OF STATIC WATER LEVEL 60 (FL) & DATE MEASURED _____

ESTIMATED YIELD 15 (GPM) & TEST TYPE AIR LIFT

TEST LENGTH 4 (Hrs.) TOTAL DRAWDOWN 620 (FL)

* May not be representative of a well's long-term yield.

TOTAL DEPTH OF BORING 620 (Feet)

TOTAL DEPTH OF COMPLETED WELL 620 (Feet)

DEPTH FROM SURFACE	BORE-HOLE DIA. (Inches)	CASING (S)						DEPTH FROM SURFACE	ANNULAR MATERIAL				
		TYPE ()				MATERIAL / GRADE	INTERNAL DIAMETER (Inches)		GAUGE OR WALL THICKNESS	SLOT SIZE IF ANY (Inches)	TYPE		
FL	TO	BLANK	SCREEN	COX	DUCTIRON			FILL PIPE			FL	TO	FL
0	55'		X					0	50'	X	Treated	In	
0	620												80' at bottom.

ATTACHMENTS ()

- Geologic Log
- Well Construction Diagram
- Geophysical Logs(s)
- Soil/Water Chemical Analyses
- Other _____

ATTACH ADDITIONAL INFORMATION IF IT EXISTS.

CERTIFICATION STATEMENT

I, the undersigned, certify that this report is complete and accurate to the best of my knowledge and belief.

NAME WATER TECH WELL DRILLING
(PERSON, FIRM, OR CORPORATION) (TYPED OR PRINTED)

P. O. Box 772 PLACERVILLE, CA. 95667

ADDRESS _____ CITY _____ STATE _____ ZIP _____

Signed [Signature] DATE SIGNED 8-14-07 STATE _____ ZIP _____

WELL DRILLER/AUTHORIZED REPRESENTATIVE DATE SIGNED 8-14-07 STATE 596278 ZIP

TRIPPLICATE
Owner's Copy

STATE OF CALIFORNIA
WELL COMPLETION REPORT

Refer to Instruction Pamphlet

No. **0912531**

DWR USE ONLY — DO NOT FILL

STATE WELL NO./STATION NO.

LATITUDE

LONGITUDE

APN/TRS/OTHER

Page 1 of 1

Owner's Well No. 1

Date Work Began Jan. 13, 2004, Ended April 6, 2004

Local Permit Agency AMADOR COUNTY HEALTH DEPT.

Permit No. W02839

Permit Date Jan. 12, 2004

WELL OWNER

GEOLOGIC LOG

ORIENTATION (°) VERTICAL HORIZONTAL ANGLE (SPECIFY)

DRILLING METHOD AIR ROTARY FLUID

DEPTH FROM SURFACE

FL to FL

DESCRIPTION

Describe material, grain size, color, etc.

FL	to	FL	DESCRIPTION
0	100		BLACK SLATE
100	300		BLACK SLATE
300	620		BLACK SLATE
620	780		BLACK SLATE

First water fracture @ 300', 5 GPM.
There was an interruption in well drilling @ 620'. Drilling was resumed to 780'. Well was lined with 4" PVC liner. Well cased in 300'. Completed well is 480' deep.

Actual water production depends upon hydrogeological conditions beyond the control of Contractor, and which are subject to dramatic changes in short periods of time. Therefore, Contractor does not warrant the continued production of any quantity or quality of water observed or reported at any stage of or at the conclusion of the project.

Name RONALD MATULICH
Mailing Address P. O. BOX 217
DRYTOWN, CA 95699
CITY STATE

WELL LOCATION

Address HWY. 49
City PLYMOUTH
County AMADOR
APN Book 008 Page 140 Parcel 028
Township _____ Range _____ Section _____
Lat _____ DEG. MIN. SEC. N Long _____ DEG. MIN. SEC. E

LOCATION SKETCH

NORTH

WEST

EAST

SOUTH

Illustrate or Describe Distance of Well from Roads, Buildings, Fences, Rivers, etc. and attach a map. Use additional paper if necessary. PLEASE BE ACCURATE & COMPLETE.

ACTIVITY

NEW WELL

MODIFICATION/REPAIR

Deepen

Other

DESTROY (See Procedures and Under "GEOLOGIC")

USES (°)

WATER SUPPLY

Domestic

Irrigation

MONITOR

TEST WE

CATHODIC PROTECT

HEAT EXCHNG

DIRECT PG

INJECT

VAPOR EXTRACT

SPARGE

REMIEDIAT

OTHER (SPECIF)

WATER LEVEL & YIELD OF COMPLETED WELL

DEPTH TO FIRST WATER 300' (FL) BELOW SURFACE

DEPTH OF STATIC WATER LEVEL 200 (FL) & DATE MEASURED XXXXXXXX 4-

ESTIMATED YIELD 5 (GPM) & TEST TYPE AIR LIFT

TEST LENGTH 4 (Hrs.) TOTAL DRAWDOWN 780 (FL)

* May not be representative of a well's long-term yield.

TOTAL DEPTH OF BORING 780' (Feet)

TOTAL DEPTH OF COMPLETED WELL 480' (Feet)

DEPTH FROM SURFACE	BORE-HOLE DIA. (Inches)	CASING (S)						DEPTH FROM SURFACE	ANNULAR MATERIAL TYPE				
		TYPE (°)	MATERIAL / GRADE	INTERNAL DIAMETER (Inches)	GAUGE OR WALL THICKNESS	SLOT SIZE IF ANY (Inches)	FL		FL	CE-MENT (°)	BEN-TONITE (°)	FILL (°)	FILTER PA (TYPE/SS)
0	60'	12	X		F480 PVC	6	160	0	55'	CEMENT GROUT	PERFORATED		
0	480				PVC LINER	4	160						

- ATTACHMENTS (°)
- Geologic Log
 - Well Construction Diagram
 - Geophysical Log(s)
 - Soil/Water Chemical Analyses
 - Other
- ATTACH ADDITIONAL INFORMATION, IF IT EXISTS

CERTIFICATION STATEMENT

I, the undersigned, certify that this report is complete and accurate to the best of my knowledge and belief.

NAME WATER TECH WELL DRILLING
(PERSON, FIRM, OR CORPORATION) (TYPED OR PRINTED)

P. O. BOX 772 PLACERVILLE, CA. 95667
ADDRESS CITY STATE ZIP

Signed Fred Stewart 4-20-04 596278

TRIPPLICATE
Owner's Copy

STATE OF CALIFORNIA
WELL COMPLETION REPORT
Refer to Instruction Pamphlet

DWR USE ONLY - DO NOT FILL IN			
STATE WELL NO (STATION NO)			
LATITUDE		LONGITUDE	
APN/RS/OTHER			

Page 1 of 1
 Owner's Well No. J
 Date Work Began Jan. 14, 2004 Ended Jan. 16, 2004
 Local Permit Agency AMADOR COUNTY HEALTH DEPT.
 Permit No. W02832 Permit Date Dec. 16, 2003
 No. **804495**

GEOLOGIC LOG

ORIENTATION (±)	<input checked="" type="checkbox"/> VERTICAL	<input type="checkbox"/> HORIZONTAL	<input type="checkbox"/> ANGLE	<input type="checkbox"/> ISPECIFY
DEPTH FROM SURFACE	DRILLING METHOD	DESCRIPTION		
FL to FL	<u>AIR ROTARY</u>	<i>Describe material, grain size, color, etc.</i>		
<u>0</u> to <u>40</u>		<u>BROWN SHALE</u>		
<u>40</u> to <u>220</u>		<u>GREEN SHALE</u>		

WELL OWNER
 Name: RONALD MATULICH
 Mailing Address: 7400 HWY. 16
PLYMOUTH, CA. 95669
 CITY STATE ZIP

WELL LOCATION
 Address: HWY. 49
 City: PLYMOUTH
 County: AMADOR
 APN Book 008 Page 110 Parcel 009-000
 Township Range Section
 Latitude Longitude

LOCATION SKETCH

ACTIVITY (±)

NEW WELL

MODIFICATION/REPAIR
 Deepen
 Other (Specify)

DESTROY (Describe Procedure and Reason Under GEOLOGIC LOG)

PLANNED USES (±)

WATER SUPPLY
 Domestic Public
 Irrigation Industrial

MONITORING
 TEST WELL
 CATHODIC PROTECTION
 HEAT EXCHANGER
 DIRECT PUSH
 INJECTION
 VAPOR EXTRACTION
 SPARGING
 REMEDIATION
 OTHER (SPECIFY)

Illustrate on 11x17 inch paper the location of well from roads, buildings, fences, ditches, etc. and attach a copy. Use additional paper if necessary. PLEASE BE ACCURATE & COMPLETE.

Actual water production depends upon hydrological conditions beyond the control of Contractor, and which are subject to dramatic changes in short periods of time. Therefore, CONTRACTOR DOES NOT warrant the continued production of any quantity or quality of water observed or reported at any stage or at the conclusion of the project.

TOTAL DEPTH OF BORING 220 (Feet)
 TOTAL DEPTH OF COMPLETED WELL, 220 (Feet)

WATER LEVEL & YIELD OF COMPLETED WELL

DEPTH TO FIRST WATER 180' (Feet) BELOW SURFACE
 DEPTH OF STATIC WATER LEVEL 30 (Feet) & DATE MEASURED 1-16-04
 ESTIMATED YIELD 70 (GPM) & TEST TYPE AIR LIFT
 TEST LENGTH 4 (Feet) TOTAL DRAWDOWN 220 (Feet)
** May not be representative of a well's long-term yield.*

DEPTH FROM SURFACE	BORE-HOLE DIA. (Inches)	CASING (S)						DEPTH FROM SURFACE	ANNULAR MATERIAL TYPE				
		TYPE (K)	MATERIAL / GRADE	INTERNAL DIAMETER (Inches)	GAUGE OR WALL THICKNESS	SLOT SIZE IF ANY (Inches)	FL to FL		CE-MENT	BEN-TONITE	FILL	FILTER PACK (TYPE/SIZE)	
0 to 60	12	X	F480 PVC	6	160		0 to 60						

- ATTACHMENTS (±)**
- Geologic Log
 - Well Construction Diagram
 - Geophysical Log(s)
 - Soil/Water Chemical Analyses
 - Other
- ATTACH ADDITIONAL INFORMATION IF IT EXISTS

CERTIFICATION STATEMENT

I, the undersigned, certify that this report is complete and accurate to the best of my knowledge and belief.

NAME WATER TECH WELL DRILLING
 (PERSON, FIRM OR CORPORATION) (TYPED OR PRINTED)

ADDRESS P. O. BOX 772 CITY PLACERVILLE, CA. 95667

DATE SIGNED 2-3-04 STATE CA LICENSE NUMBER 596278

Signature: Fred Stewart
 WELL DRILLER/AUTHORIZED REPRESENTATIVE

DUPLICATE
Driller's Copy

STATE OF CALIFORNIA
WELL COMPLETION REPORT
Subject to Instruction Paragraphs

DWR USE ONLY - DO NOT FILL IN

STATE WELL REGISTRATION NO.

LATITUDE

LONGITUDE

APN/TRS/OTHER

Page: 1 of 1
 Owner's Well No. 3 No. 804439
 Date Work Began Feb. 19, 2004 Ended Feb. 20, 2004
 Local Permit Agency AMADOR COUNTY HEALTH DEPT.
 Permit No. W02851 Permit Date Feb. 11, 2004

ORIENTATION (<) VERTICAL HORIZONTAL ANGLE (DEGREE)

DRAINING METHOD AIR ROTARY FLIGHT

DESCRIPTION

Describe material, grain size, color, etc.

DEPTH FROM SURFACE	FT	TO	FT	DESCRIPTION
0	80			BROWN SHALE
80	200			BLACK SLATE
200	340			BLACK SLATE

First water fracture @ 200', 5 GPM
 Second water fracture @ 240', 10 GPM

WELL OWNER

Name RONALD G. MATULICH
 Mailing Address P. O. BOX 217
DRYTOWN, CA. 95699
 CITY STATE ZIP

WELL LOCATION

Address 16711 CAL MINE RD.
 City PLYMOUTH
 County AMADOR
 APN Book 08 Page 140 Parcel 014
 Township Range Section
 Latitude: _____ NORTH Longitude: _____

ACTUAL WATER PRODUCTION UNDER UNUSUAL HYDROLOGICAL CONDITIONS BEYOND THE CONTROL OF CONTRACTOR, AND WHICH ARE SUBJECT TO DRAMATIC CHANGES IN SHORT PERIODS OF TIME. THEREFORE, CONTRACTOR DOES NOT WARRANT THE CONTINUED PRODUCTION OF ANY QUANTITY OR QUALITY OF WATER OBSERVED OR REPORTED AT ANY STAGE OF OR AT THE COMPLETION OF THE PROJECT.

LOCATION SKETCH NORTH

COPY

ACTIVITY (<)

NEW WELL

MODIFICATION/REPAIR

DESTROY EXISTING

PLANNED USES (<)

WATER SUPPLY Public

HEATING Industrial

MINING

TEST WELL

CATHODIC PROTECTION

HEAT EXCHANGE

DIRECT PUMP

INJECTION

VAPOR EXTRACTION

SPARGING

REMEDIATION

OTHER (SPECIFY)

WATER LEVEL & YIELD OF COMPLETED WELL

DEPTH TO FIRST WATER 200' (FT) BELOW SURFACE

DEPTH OF STATIC WATER LEVEL 45' (FT) & DATE MEASURED 2-20-04

ESTIMATED YIELD 15 (GPM) & TEST TYPE AIR LIFT

TEST LENGTH 4 (FT) TOTAL DRAYCROWN _____ (FT)

* May not be representative of a well's long-term yield.

DEPTH FROM SURFACE	BORE-HOLE DIA. (inches)	CASING (IN)				MATERIAL / GRADE	INTERNAL DIAMETER (inches)	GAUGE OR WALL THICKNESS	SLOT SIZE IF ANY (inches)	ANNULAR MATERIAL				
		TYPE (IN)	SCREEN	DUCTOR	PULL PIPE					DEPTH FROM SURFACE	CEMENT (in)	BENTONITE (in)	FILL (in)	FILTER PACK (TYPE/SIZE)
0 - 60	12	X				F80 PVC	6	160		0 - 60'				CONCRETE GROUT PUMPED
60 - 340						PVC LINER	4	160	PERFORATED AT BOTTOM.	60'				SEAL.

ATTACHMENTS (<)

Geologic Log

Well Construction Diagram

Geophysical Log(s)

Soil/Water Chemical Analyses

Other _____

ATTACH ADDITIONAL INFORMATION IF IT EXISTS

CERTIFICATION STATEMENT

I, the undersigned, certify that this report is complete and accurate to the best of my knowledge and belief.

NAME WATER TECH WELL DRILLING
 (PERSON, FIRM OR CORPORATION, LIMITED OR PARTNER)

P. O. BOX 772 PLACERVILLE, CA. 95667
 ADDRESS CITY STATE ZIP

Signed Fred Stewart DATE SIGNED 3-22-04 EST. LICENSE NUMBER 596278
 WELL DRILLER/AUTHORIZED REPRESENTATIVE

ORIGINAL
File with DWR

STATE OF CALIFORNIA
THE RESOURCES AGENCY
DEPARTMENT OF WATER RESOURCES
WATER WELL DRILLERS REPORT

Do not fill in
No. 052067

of Intent No. _____
Local Permit No. or Date _____

State Well No. _____
Other Well No. _____

(1) OWNER: Name Roll Hunter
Address P.O. Box 21
City Jackson, CA Zip 95662

(2) LOCATION OF WELL (See instructions):
County Colusa Owner's Well Number # 1
Well address if different from above Box 49 in Plymouth
Township 7N Range 10E Section 11
Distance from cities, roads, railroads, fences, etc. _____

(12) WELL LOG: Total depth 223 ft. Depth of completed well 223 ft.

from ft.	to ft.	Formation (Describe by color, character, size or material)
0	10	Wire tailings
10	40	Overburden
40	50	Shale
50	75	Broken slate
75	105	Hard slate
105	107	Broken slate & quartz (water bearing)
107	200	Hard slate & quartz
200	205	broken slate & quartz (water bearing)
205	223	hard slate

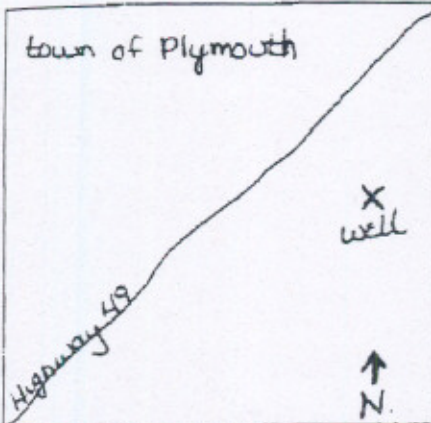

(3) TYPE OF WORK:
New Well Deepening
Reconstruction
Reconditioning
Horizontal Well
Destruction (Describe destruction materials and procedures in Item 12)

(4) PROPOSED USE:
Domestic
Irrigation
Industrial
Test Well
Stock
Municipal
Other

(5) EQUIPMENT:
Roney Reverse
Cable Air
Other Bucket

(6) GRAVEL PACK:
Yes No Size _____
Quantity of bore _____
Packed from _____ ft.

(7) CASING INSTALLED:

From ft.	To ft.	Dis. in.	Cops or Wall
0	50	6.0	12

(8) PERFORATIONS:

From ft.	To ft.	Slot size

(9) WELL SEAL:
Was surface sanitary seal provided? Yes No If yes, to depth 50 ft.
Were struts sealed against pollution? Yes No Interval _____ ft.
Method of sealing Neat Cement grout

(10) WATER LEVELS:
Depth of first water, if known 105 ft.
Standing level after well completion 72 ft.

(11) WELL TESTS:
Was well test made? Yes No If yes, by whom? Briski
Type of test: Pump Bailor Air lift
Depth to water at start of test _____ ft. At end of test _____ ft.
rate 150 gal/min after 4 hours Water temperature _____
Chemical analysis made? Yes No If yes, by whom? _____
Was electric log made? Yes No If yes, attach copy to this report

Work started 11-2 1977 Completed 11-3 1977

WELL DRILLER'S STATEMENT:
This well was drilled under my jurisdiction and this report is true to the best of my knowledge and belief.
SIGNED Greg A. Briski (Well Driller)
NAME Briski Well Drilling Company (Person, firm, or corporation) (Typed or printed)
Address P.O. Box 727
City San Andreas, CA Zip 95249
License No. 272647 Date of this report 9-20-78

APPENDIX B

Pumping Test Data

Ione Pumping Test Data

Pumped Well is M1

Drawdown in M1

Date	Time	Cumulative Time (min)	Flow Rate (gpm)	DTW (ft)	Drawdown (ft)
12/13	1300	0	0.0	52.7	0
12/13	1304	4	37.9	66.9	14.2
12/13	1305	5	37.1	94	41.3
12/13	1306	6	36.1	115.9	63.2
12/13	1307	7	35.5	136.1	83.4
12/13	1308	8	35.0	151	98.3
12/13	1310	10	33.5	188.1	135.4
12/13	1315	15	30.9	268.8	216.1
12/13	1320	20	29.2	317	264.3
12/13	1325	25	26.7	366.5	313.8
12/13	1330	30	25.2	405.2	352.5
12/13	1335	35	23.9	434.2	381.5
12/13	1340	40	22.8	460.8	408.1
12/13	1345	45	22.3	474.7	422
12/13	1350	50	21.5	491.4	438.7
12/13	1355	55	21.1	500.74	448.04
12/13	1400	60	20.7	509.8	457.1
12/13	1405	65	20.5	514.71	462.01
12/13	1407	67	16.6	513.35	460.65
12/13	1410	70	19.8	514.49	461.79
12/13	1415	75	19.0	513.85	461.15
12/13	1420	80	18.9	513.93	461.23
12/13	1430	90	18.8	513.87	461.17
12/13	1458	118	18.7	514.19	461.49
12/13	1500	120	19.0	515.3	462.6
12/13	1530	150	18.5	516.4	463.7
12/13	1535	155	18.4	516.42	463.72
12/13	1545	165	18.4	516.69	463.99
12/13	1555	175	18.5	517.96	465.26
12/13	1605	180	18.2	517.49	464.79
12/13	1610	185	18.2	517.08	464.38
12/13	1615	190	18.3	517.24	464.54
12/13	1623	198	18.3	517.4	464.7
12/13	1630	205	18.3	517.62	464.92
12/13	1640	215	18.2	517.93	465.23
12/13	1650	225	18.3	518.78	466.08
12/13	1700	235	18.1	519.2	466.5
12/13	1705	240	18.1	519.32	466.62
12/13	1713	248	18.1	519.2	466.5
12/13	1720	255	18.1	519.19	466.49
12/14	1442	1586	17.1	531.75	479.05
12/15	820	2595	17.1	536.04	483.34
12/15	847	2622	17.1	536.06	483.36
12/15	854	2629	16.9	536.02	483.32
12/15	925	2660	16.9	533.29	480.59
12/15	930	2665	16.9	533.33	480.63
12/15	932	2667	16.9	533.05	480.35
12/15	935	2670	16.9	532.9	480.2
12/15	937	2672	17.0	533.86	481.16
12/15	941	2676	17.0	533.1	480.4
12/15	945	2680	17.0	533.12	480.42
12/15	948	2683	17.0	533.13	480.43

12/15	950	2685	17.0	533.01	480.31
12/15	951	2686	17.0	532.64	479.94
12/15	952	2687	17.0	532.68	479.98
12/15	954	2689	17.0	532.7	480
12/15	956	2691	17.0	532.9	480.2
12/15	957	2692	17.0	532.65	479.95
12/15	959	2694	17.0	532.88	480.18
12/15	1000	2695	17.0	532.78	480.08
12/15	1001	2696	17.0	532.9	480.2
12/15	1002	2697	17.0	532.78	480.08
12/15	1006	2701	17.0	532.82	480.12
12/15	1007	2702	17.0	532.7	480
12/15	1008	2703	17.0	552.6	499.9
12/15	1009	2704	17.0	532.6	479.9
12/15	1010	2705	16.9	532.79	480.09
12/15	1012	2707	17.0	532.64	479.94
12/15	1013	2708	17.0	532.65	479.95
12/15	1015	2710	17.0	532.6	479.9
12/15	1024	2719	17.0	532.89	480.19
12/15	1026	2721	16.9	532.5	479.8
12/15	1028	2723	17.0	532.4	479.7
12/15	1030	2725	17.0	532.42	479.72
12/15	1036	2731	17.0	532.34	479.64
12/15	1038	2733	17.0	532.29	479.59
12/15	1042	2737	17.0	532.13	479.43
12/15	1045	2740	17.0	532.2	479.5
12/15	1049	2744	17.0	532.2	479.5
12/15	1052	2747	17.0	532.09	479.39
12/15	1054	2749	17.0	532.08	479.38
12/15	1059	2754	17.0	532	479.3
12/15	1101	2756	17.0	531.9	479.2
12/15	1109	2764	17.0	531.95	479.25
12/15	1112	2767	17.0	531.96	479.26
12/15	1117	2772	17.0	532.2	479.5
12/15	1119	2774	17.0	532.25	479.55
12/15	1138	2793	17.0	532.36	479.66
12/15	1143	2798	17.0	532.69	479.99
12/15	1159	2814	17.0	532.51	479.81
12/15	1206	2821	17.0	532.31	479.61
12/15	1212	2827	17.0	532.6	479.9
12/15	1224	2839	17.0	532.42	479.72
12/15	1228	2843	17.0	532.57	479.87
12/15	1234	2849	17.0	532.5	479.8
12/15	1240	2855	17.0	532.32	479.62
12/15	1246	2861	17.0	532.1	479.4
12/15	1252	2867	17.0	532.16	479.46
12/15	1258	2873	17.0	532.15	479.45
12/15	1320	2895	17.0	532.17	479.47
12/16	822	4037	0.0	533.06	480.36

Ione Pumping Test Data

Pumped Well is M1

Recovery in M1

Date	Time	Cumulative Time (min)	DTW (ft)	Drawdown (ft)
12/16	822	0.0	533.06	480.4
12/16	832	10.0	533.09	480.4
12/16	832	10.3	530.3	477.6
12/16	832	10.7	528	475.3
12/16	833	12.0	527	474.3
12/16	833	12.3	526	473.3
12/16	833	12.5	525	472.3
12/16	833	12.6	522.8	470.1
12/16	833	12.6	522.2	469.5
12/16	833	12.7	521	468.3
12/16	833	12.8	520	467.3
12/16	833	12.8	518.5	465.8
12/16	833	12.9	517.5	464.8
12/16	833	12.9	516	463.3
12/16	834	14.0	515	462.3
12/16	834	14.1	513.5	460.8
12/16	834	14.2	512.5	459.8
12/16	834	14.3	511.5	458.8
12/16	834	14.4	510.5	457.8
12/16	834	14.5	509.5	456.8
12/16	834	14.6	508	455.3
12/16	834	14.7	507.5	454.8
12/16	834	14.8	506.5	453.8
12/16	834	14.8	505.5	452.8
12/16	834	14.9	504	451.3
12/16	834	14.9	503	450.3
12/16	835	16.0	502	449.3
12/16	835	16.1	500.5	447.8
12/16	835	16.2	499.5	446.8
12/16	835	16.2	499	446.3
12/16	835	16.3	498	445.3
12/16	835	16.4	496.5	443.8
12/16	835	16.5	495.5	442.8
12/16	835	16.6	494.5	441.8
12/16	835	16.7	493.5	440.8
12/16	835	16.7	492.5	439.8
12/16	835	16.8	491.5	438.8
12/16	835	16.9	490.5	437.8
12/16	835	16.9	490	437.3
12/16	836	18.0	488.5	435.8
12/16	836	18.1	487.5	434.8
12/16	836	18.2	486.5	433.8
12/16	836	18.2	485.5	432.8
12/16	836	18.3	484.5	431.8
12/16	836	18.4	483.5	430.8
12/16	836	18.5	482.4	429.7
12/16	836	18.6	481.6	428.9
12/16	836	18.7	480.7	428.0
12/16	836	18.7	479.5	426.8
12/16	836	18.9	477.7	425.0
12/16	837	20.0	476.6	423.9
12/16	837	20.1	475.5	422.8

12/16	837	20.2	474.2	421.5
12/16	837	20.2	473	420.3
12/16	837	20.4	472	419.3
12/16	837	20.5	470.7	418.0
12/16	837	20.6	469.6	416.9
12/16	837	20.7	468.3	415.6
12/16	837	20.7	467.1	414.4
12/16	837	20.8	466.1	413.4
12/16	837	20.9	465	412.3
12/16	838	22.0	463.3	410.6
12/16	838	22.2	461.5	408.8
12/16	838	22.3	458.5	405.8
12/16	838	22.5	457.3	404.6
12/16	838	22.7	455.8	403.1
12/16	838	22.8	454.2	401.5
12/16	838	22.9	452.5	399.8
12/16	839	24.0	450.9	398.2
12/16	839	24.2	448.9	396.2
12/16	839	24.4	447.4	394.7
12/16	839	24.5	445.6	392.9
12/16	839	24.6	443.9	391.2
12/16	839	24.7	443	390.3
12/16	839	24.8	441.6	388.9
12/16	839	24.9	440.1	387.4
12/16	840	26.0	439	386.3
12/16	840	26.1	438.4	385.7
12/16	840	26.2	437.2	384.5
12/16	840	26.2	436.1	383.4
12/16	840	26.3	435.1	382.4
12/16	840	26.4	434.1	381.4
12/16	840	26.5	433.1	380.4
12/16	840	26.6	432.2	379.5
12/16	840	26.7	431.1	378.4
12/16	840	26.8	430.1	377.4
12/16	840	26.9	429.1	376.4
12/16	841	28.0	428.3	375.6
12/16	841	28.1	426.6	373.9
12/16	841	28.2	424.8	372.1
12/16	841	28.7	423.3	370.6
12/16	842	29.0	421.6	368.9
12/16	842	29.7	419.5	366.8
12/16	842	29.9	417.4	364.7
12/16	843	31.0	415.5	362.8
12/16	843	31.2	413.7	361.0
12/16	843	31.4	412.8	360.1
12/16	843	31.5	411.5	358.8
12/16	843	31.6	410.1	357.4
12/16	843	31.7	408.6	355.9
12/16	844	33.0	405	352.3
12/16	844	33.2	403.7	351.0
12/16	844	33.3	402	349.3
12/16	844	33.5	400.5	347.8
12/16	844	33.6	398.3	345.6
12/16	844	33.7	396.5	343.8
12/16	845	35.0	394.4	341.7
12/16	845	35.2	392.5	339.8
12/16	845	35.3	391.2	338.5
12/16	845	35.5	389	336.3
12/16	845	35.7	386.9	334.2

12/16	846	37.0	384.3	331.6
12/16	846	37.4	382.5	329.8
12/16	846	37.7	376.7	324.0
12/16	847	39.0	372.6	319.9
12/16	848	40.0	363.7	311.0
12/16	849.5	41.5	350.3	297.6
12/16	850	42.2	342.5	289.8
12/16	851	43.2	332.9	280.2
12/16	851	43.8	327	274.3
12/16	852	44.8	318	265.3
12/16	853	45.9	308.5	255.8
12/16	854	46.7	301.2	248.5
12/16	855	47.8	292.4	239.7
12/16	856	48.8	285.2	232.5
12/16	857	49.9	277	224.3
12/16	858	50.8	270.1	217.4
12/16	859	51.9	262.2	209.5
12/16	900	52.9	254.6	201.9
12/16	901	53.9	248.5	195.8
12/16	903	55.1	240.4	187.7
12/16	904	56.1	234.2	181.5
12/16	905	57.1	228.1	175.4
12/16	906	58.1	222.5	169.8
12/16	907	59.1	217.6	164.9
12/16	908	60.1	213	160.3
12/16	909	61.0	208.2	155.5
12/16	910	62.1	202.7	150.0
12/16	911	63.1	197.6	144.9
12/16	912	64.2	192.8	140.1
12/16	913	65.2	187.9	135.2
12/16	914	66.5	183	130.3
12/16	915	67.3	179	126.3
12/16	916	68.5	175.6	122.9
12/16	917	69.5	172.7	120.0
12/16	918	70.6	169.7	117.0
12/16	919	71.7	166.1	113.4
12/16	920	72.5	163.8	111.1
12/16	921	73.5	160.8	108.1
12/16	922	74.6	157.9	105.2
12/16	923	75.5	155.2	102.5
12/16	924	76.6	152.6	99.9
12/16	925	77.5	150.7	98.0
12/16	926	78.7	148.3	95.6
12/16	927	79.5	147	94.3
12/16	928	80.6	145	92.3
12/16	929	81.7	143.3	90.6
12/16	930	82.5	141.9	89.2
12/16	931	83.5	140.2	87.5
12/16	932	84.5	139	86.3
12/16	933	85.5	137.8	85.1
12/16	934	86.5	136.8	84.1
12/16	935	87.4	135.9	83.2
12/16	936	88.4	134.4	81.7
12/16	937	89.5	133.2	80.5
12/16	938	90.5	132.2	79.5
12/16	939	91.6	131.1	78.4
12/16	940	92.9	130	77.3
12/16	941	93.7	129.4	76.7
12/16	942	94.8	128.8	76.1

12/16	943	95.6	128	75.3
12/16	944	96.7	127.3	74.6
12/16	945	97.5	126.8	74.1
12/16	946	98.4	126.3	73.6
12/16	947	99.6	125.6	72.9
12/16	948	100.6	125.1	72.4
12/16	949	101.3	124.7	72.0
12/16	950	102.5	124.1	71.4
12/16	951	103.6	123.6	70.9
12/16	952	104.9	123.2	70.5
12/16	955	107.0	122.15	69.5
12/16	1000	112.0	120.5	67.8
12/16	1005	117.0	119.1	66.4
12/16	1010	122.0	117.78	65.1
12/16	1015	127.0	116.66	64.0
12/16	1016	128.0	115.59	62.9
12/16	1026	138.0	114.02	61.3
12/16	1030	142.0	112.81	60.1
12/16	1038	150.0	111.34	58.6
12/16	1042	154.0	110.36	57.7
12/16	1118	190.0	103.48	50.8
12/16	1133	205.0	100.68	48.0
12/16	1145	217.0	98.88	46.2
12/16	1403	355.0	81	28.3
12/16	1553	465.0	71.81	19.1
12/16	1700	532.0	67.5	14.8

Ione Pumping Test Data

Pumped Well is M3

Drawdown in M3

Date	Time	Cumulative Time (min)	Flow Rate (gpm)	DTW (ft)	GW ELE (ft)	Drawdown (ft)
07/07/04	8:30:00 AM	0	0.0	42.37	933.63	0
	9:00:00 AM	0	75.0	42.31	933.69	3.79
	9:01:00 AM	1	75.3	43.62	932.38	5.1
	9:02:00 AM	2	75.2	43.84	932.16	5.32
	9:04:00 AM	4	75.2	44.27	931.73	5.75
	9:08:00 AM	8	75.2	44.92	931.08	6.4
	9:15:00 AM	15	75.0	45.72	930.28	7.2
	9:30:00 AM	30	74.9	47.03	928.97	8.51
	10:00:00 AM	60	74.7	48.89	927.11	10.37
	11:00:00 AM	120	74.9	51.82	924.18	13.3
	12:00:00 PM	180	74.5	53.31	922.69	14.79
	2:00:00 PM	300	74.7	55.63	920.37	17.11
	4:00:00 PM	420	74.8	57.00	919.00	18.48
	5:00:00 PM	480	75.3	57.51	918.49	18.99
	7:00:00 PM	600	75.0	58.31	917.69	19.79
	9:00:00 PM	720	74.3	58.92	917.08	20.4
07/08/04	9:00:00 AM	1440	73.7	60.81	915.19	22.29
	11:00:00 AM	1560	75.3	61.14	914.86	22.62
	1:00:00 PM	1680	75.2	61.41	914.59	22.89
	3:00:00 PM	1800	75.2	61.63	914.37	23.11
07/09/04	9:00:00 AM	2160	74.7	63.58	912.42	25.06
	9:00:00 PM	2880	74.3	65.02	910.98	26.5
07/10/04	9:00:00 AM	3600	73.6	66.57	909.43	28.05
07/11/04	9:00:00 AM	5040	73.3	70.33	905.67	31.81
07/12/04	9:00:00 AM	6480	73.1	73.89	902.11	35.37
	11:40:00 AM	6640	74.0	74.23	901.77	35.71

IONE PUMPING TEST

Pumped Well is M3

Recovery in M3

Date	Time (min)	Cumulative Time (min)	Flow Rate (gpm)	DTW (ft)	GW ELE (ft)	Drawdown (ft)
07/12/04	11:40:00 AM	0	74	74.23	901.77	35.71
	11:41:00 AM	1	0	73.36	902.64	34.84
	11:42:00 AM	2	0	73.17	902.83	34.65
	11:43:00 AM	3	0	73.13	902.87	34.61
	11:44:00 AM	4	0	73.07	902.93	34.55
	11:45:00 AM	5	0	72.98	903.02	34.46
	11:46:00 AM	6	0	72.90	903.10	34.38
	11:48:00 AM	8	0	72.78	903.22	34.26
	11:50:00 AM	10	0	72.67	903.33	34.15
	11:52:00 AM	12	0	72.57	903.43	34.05
	11:55:00 AM	15	0	72.42	903.58	33.90
	12:00:00 PM	20	0	72.17	903.83	33.65
	12:10:00 PM	30	0	71.86	904.14	33.34
	12:20:00 PM	40	0	71.57	904.43	33.05
	12:30:00 PM	50	0	71.31	904.69	32.79
	12:40:00 PM	60	0	71.11	904.89	32.59
	12:55:00 PM	75	0	70.83	905.17	32.31
	01:10:00 PM	90	0	70.60	905.40	32.08
	01:30:00 PM	110	0	70.33	905.67	31.81
	01:40:00 PM	120	0	70.21	905.79	31.69
	01:50:00 PM	130	0	70.15	905.85	31.63
	02:40:00 PM	180	0	69.67	906.33	31.15
	03:40:00 PM	240	0	69.17	906.83	30.65
	04:40:00 PM	300	0	68.75	907.25	30.23
	05:40:00 PM	360	0	68.37	907.63	29.85
	06:40:00 PM	420	0	68.08	907.92	29.56
07/13/04	09:00:00 AM	1280	0	65.27	910.73	26.75
	11:00:00 AM	1400	0	65.02	910.98	26.50
07/14/04	09:30:00 AM	2750	0	62.67	913.33	24.15
07/15/04	10:48:00 AM	4268	0	60.87	915.13	22.35
07/16/04	04:53:00 PM	6073	0	59.29	916.71	20.77
07/19/04	09:00:00 AM	9920	0	57.15	918.85	18.63
07/21/04	10:01 AM	12861	0	55.96	920.04	17.44
07/23/04	01:00 PM	15920	0	54.90	921.10	16.38

Ione Pumping Test Data

Pumped Well is M3

Stepped Drawdown in M3

Date	Time (min)	Cumulative Time (min)	Flow Rate (gpm)	DTW (ft)	GW ELE (ft)	Drawdown (ft)
07/06/04	10:03 AM		0	38.18	937.82	0
	11:32 AM		0	38.20	937.80	0.02
	11:46 AM		0	38.20	937.80	0.02
	02:46 PM	0	50.8	39.75	936.25	1.57
	02:48 PM	2	49.8	39.85	936.15	1.67
	02:50 PM	4	49.8	40.08	935.92	1.9
	02:52 PM	6	60.6	40.62	935.38	2.44
	02:54 PM	8	60.0	40.82	935.18	2.64
	02:56 PM	10	59.9	41.03	934.97	2.85
	02:58 PM	12	60.0	41.22	934.78	3.04
	03:00 PM	14	60.2	41.40	934.60	3.22
	03:05 PM	19	59.0	41.86	934.14	3.68
	03:10 PM	24	60.1	42.26	933.74	4.08
	03:15 PM	29	60.0	42.61	933.39	4.43
	03:20 PM	34	60.0	42.97	933.03	4.79
	03:30 PM	44	59.9	43.58	932.42	5.4
	03:40 PM	54	59.8	44.14	931.86	5.96
	03:50 PM	64	60.1	44.67	931.33	6.49
	04:00 PM	74	60.1	45.19	930.81	7.01
	04:17 PM	91	60.0	45.93	930.07	7.75
	04:30 PM	104	60.0	46.47	929.53	8.29
	04:45 PM	119	60.1	47.03	928.97	8.85
	05:00 PM	134	60.2	47.54	928.46	9.36
	05:37 PM	171	60.0	48.62	927.38	10.44
	05:45 PM	179	60.0	48.96	927.04	10.78
	06:00 PM	194	70.1	49.83	926.17	11.65
	06:15 PM	209	70.1	50.39	925.61	12.21
	06:30 PM	224	70.0	50.86	925.14	12.68
	06:45 PM	239	70.0	51.29	924.71	13.11
	07:00 PM	254	70.0	51.71	924.29	13.53
	07:05 PM	259	0	50.11	925.89	11.93
	07:10 PM	264	0	49.67	926.33	11.49
	07:15 PM	269	0	49.33	926.67	11.15
	07:20 PM	274	0	49.11	926.89	10.93
	07:25 PM	279	0	48.88	927.12	10.7
	07:30 PM	284	0	48.66	927.34	10.48
	07:35 PM	289	0	48.46	927.54	10.28
	07:40 PM	294	0	48.25	927.75	10.07
	07:45 PM	299	0	48.14	927.86	9.96
	07:50 PM	304	0	47.99	928.01	9.81
	07:55 PM	309	0	47.83	928.17	9.65
	08:00 PM	314	0	47.70	928.30	9.52
07/07/04	08:30 AM	1064	0	42.37	933.63	4.19

Ione Pumping Test Data

Pumped Well is M3

Observation Well H1

Date	Time (min)	Cumulative Time (min)	Flow Rate (gpm)	DTW (ft)	GW ELE
07/06/04	11:02 AM	0	0	76.43	996.57
	05:21 PM	379	0	76.29	996.71
	08:33 PM	571	0	76.25	996.75
07/07/04	07:53 AM	1251	0	76.82	996.18
	10:29 AM	1407	0	76.42	996.58
	12:38 PM	1536	0	76.36	996.64
	02:40 PM	1658	0	76.32	996.68
	04:40 PM	1778	0	76.27	996.73
	07:41 PM	1959	0	76.23	996.77
07/08/04	09:44 AM	2802	0	76.52	996.48
	11:40 AM	2918	0	76.44	996.56
	01:38 PM	3036	0	76.39	996.61
07/09/04	09:41 AM	4239	0	76.73	996.27
07/10/04	09:55 AM	4253	0	76.89	996.11
07/11/04	11:20 AM	4338	0	76.64	996.36
07/12/04	09:12 AM	5650	0	76.56	996.44
	05:11 PM	6129	0	76.43	996.57
07/13/04	09:59 AM	7137	0	76.85	996.15
	11:34 AM	7232	0	76.76	996.24
07/14/04	10:29 AM	8607	0	76.93	996.07
07/15/04	12:44 PM	10182	0	76.82	996.18
07/16/04	05:24 PM	11902	0	76.80	996.20
07/19/04	10:56 AM	15834	0	77.33	995.67

Ione Pumping Test Data

Pumped Well is M3

Observation Well M2

Date	Time (min)	Cumulative Time (min)	Flow Rate (gpm)	DTW (ft)	GW ELE (ft)
07/06/04	10:48 AM	0	0	74.45	854.55
	04:09 PM	321	0	74.72	854.28
	05:10 PM	382	0	74.74	854.26
	08:17 PM	569	0	74.53	854.47
07/07/04	08:11 AM	1283	0	74.52	854.48
	10:16 AM	1408	0	74.50	854.50
	12:22 PM	1534	0	74.54	854.46
	02:23 PM	1655	0	74.62	854.38
	04:20 PM	1772	0	74.68	854.32
	05:21 PM	1833	0	74.68	854.32
	07:24 PM	1956	0	74.66	854.34
	07:30 PM	1962	0	74.52	854.48
07/08/04	09:29 AM	2801	0	74.59	854.41
	11:24 AM	2916	0	74.58	854.42
	01:24 PM	3036	0	74.58	854.42
	01:28 PM	3040	0	74.64	854.36
07/09/04	09:27 AM	4239	0	74.78	854.22
	09:33 PM	4965	0	74.67	854.33
07/10/04	09:40 AM	5692	0	74.89	854.11
07/11/04	11:02 AM	5774	0	74.94	854.06
07/12/04	09:26 AM	7118	0	75.02	853.98
	03:18 PM	7470	0	74.74	854.26
	03:55 PM	7507	0	74.72	854.28
	04:55 PM	7567	0	74.66	854.34
	05:58 PM	7630	0	74.60	854.40
	06:56 PM	7688	0	74.64	854.36
07/13/04	09:26 AM	8558	0	75.06	853.94
	11:20 AM	8672	0	75.11	853.89
07/14/04	10:03 AM	10035	0	75.15	853.85
07/15/04	11:24 AM	11556	0	75.26	853.74
07/16/04	05:11 PM	13343	0	74.99	854.01
07/19/04	10:14 AM	17246	0	75.11	853.89
07/21/04	09:48 AM	20100	0	75.10	853.90

Ione Pumping Test Data

Pumped Well is M3

Observation Well M4

Date	Time (min)	Cumulative Time (min)	Flow Rate (gpm)	DTW (ft)	GW ELE (ft)
07/06/04	09:59 AM	0	0	43.23	951.77
	11:35 AM	0	0	43.26	951.74
	03:32 PM	237	0	43.42	951.58
	03:52 PM	257	0	43.45	951.55
	04:55 PM	320	0	43.58	951.42
	05:48 PM	373	0	43.69	951.31
	06:32 PM	417	0	43.81	951.19
	07:02 PM	447	0	43.89	951.11
	07:32 PM	477	0	43.95	951.05
	08:02 PM	507	0	44.01	950.99
07/07/04	08:26 AM	1251	0	44.72	950.28
	09:18 AM	1303	0	44.75	950.25
	10:03 AM	1348	0	44.83	950.17
	12:06 PM	1471	0	45.13	949.87
	02:07 PM	1592	0	45.50	949.50
	04:08 PM	1713	0	45.86	949.14
	05:10 PM	1775	0	46.04	948.96
	07:07 PM	1892	0	46.37	948.63
	09:14 PM	2019	0	46.72	948.28
07/08/04	09:14 AM	2739	0	48.74	946.26
	11:09 AM	2854	0	48.98	946.02
	01:08 PM	2973	0	49.23	945.77
	03:10 PM	3095	0	49.48	945.52
07/09/04	09:11 AM	4176	0	51.34	943.66
	09:17 PM	4902	0	52.24	942.76
07/10/04	09:22 AM	5627	0	53.29	941.71
07/11/04	10:10 AM	5675	0	55.43	939.57
07/12/04	09:41 AM	7086	0	57.60	937.40
	11:35 AM	7200	0	57.75	937.25
	11:58 AM	7223	0	57.77	937.23
	12:24 PM	7249	0	57.78	937.22
	12:43 PM	7268	0	57.78	937.22
	12:58 PM	7283	0	57.78	937.22
	01:35 PM	7320	0	57.80	937.20
	02:06 PM	7351	0	57.80	937.20
	03:44 PM	7449	0	57.80	937.20
	04:44 PM	7509	0	57.81	937.19
	05:46 PM	7571	0	57.82	937.18
	06:45 PM	7630	0	57.86	937.14
07/13/04	09:11 AM	8496	0	58.23	936.77
	11:09 AM	8614	0	58.25	936.75
07/14/04	09:44 AM	9969	0	58.25	936.75
07/15/04	11:01 AM	11486	0	58.11	936.89
07/16/04	04:58 PM	13283	0	57.74	937.26
07/19/04	10:29 AM	17214	0	57.63	937.37
07/21/04	10:05 AM	20070	0	57.63	937.37

One Pumping Test Data
 Pumped Well is H1
 Drawdown in H1

Date	Time	Cumulative Time (min)	Flow Rate (gpm)	DTW (ft)	Drawdown (ft)
12/02	1500	0	60	81.17	0
12/02	1504	4	60	83.26	2.09
12/02	1505	5	60	83.36	2.19
12/02	1506	6	60	83.5	2.33
12/02	1507	7	60	83.41	2.24
12/02	1509	9	60	83.47	2.3
12/02	1510	10	60	83.56	2.39
12/02	1513	13	60	83.56	2.39
12/02	1514	14	60	83.61	2.44
12/02	1515	15	60	83.65	2.48
12/02	1516	16	60	83.71	2.54
12/02	1517	17	60	83.74	2.57
12/02	1518	18	60	83.81	2.64
12/02	1519	19	60	83.83	2.66
12/02	1520	20	60	83.85	2.68
12/02	1521	21	60	83.86	2.69
12/02	1522	22	60	83.87	2.7
12/02	1525	25	60	83.95	2.78
12/02	1530	30	60	84.15	2.98
12/02	1535	35	60	84.18	3.01
12/02	1540	40	60	84.32	3.15
12/02	1545	45	60	84.4	3.23
12/02	1550	50	60	84.57	3.4
12/02	1555	55	60	84.68	3.51
12/02	1600	60	60	84.81	3.64
12/02	1605	65	60	84.91	3.74
12/02	1610	70	60	85.01	3.84
12/02	1615	75	60	85.14	3.97
12/02	1620	80	60	85.25	4.08
12/02	1625	85	60	85.36	4.19
12/02	1638	98	60	85.57	4.4
12/03	829	1049	60	95.99	14.82
12/03	839	1059	60	96.05	14.88
12/03	930	1150	60	96.51	15.34
12/03	932	1152	60	96.52	15.35
12/03	934	1154	60	96.52	15.35
12/03	936	1156	60	96.59	15.42
12/03	938	1158	60	96.57	15.4
12/03	940	1160	60	96.61	15.44
12/03	950	1170	60	96.72	15.55
12/03	1000	1180	60	96.75	15.58
12/03	1010	1190	60	96.86	15.69
12/03	1020	1200	60	96.91	15.74
12/03	1030	1210	60	96.92	15.75
12/03	1040	1220	60	97.08	15.91
12/03	1050	1230	60	97.06	15.89
12/03	1100	1240	60	97.11	15.94
12/03	1729	1629	60	99.78	18.61
12/03	1734	1634	60	99.85	18.68
12/04	930	2590	60	98.3	17.13
12/04	1106	2686	60	97.84	16.67

12/04	1111	2691	60	99.89	18.72
12/04	1116	2696	60	100	18.83
12/04	1121	2701	60	100.08	18.91
12/04	1126	2706	60	100.38	19.21
12/04	1136	2716	60	100.41	19.24
12/04	1148	2728	60	100.57	19.4
12/05	805	3945	60	108.87	27.7
12/05	810	3950	60	108.87	27.7
12/05	815	3955	60	108.92	27.75
12/05	1915	4615	60	111.52	30.35
12/06	1135	5595	60	114.02	32.85
12/07	1525	7265	60	120.1	38.93
12/08	824	8284	60	122.84	41.67
12/08	830	8290	60	122.73	41.56
12/08	1115	8455	60	123.28	42.11
12/08	1122	8462	60	123.32	42.15
12/08	1128	8468	60	121.24	40.07
12/08	1128.5	8468.5	60	121.42	40.25
12/08	1129	8469	60	121.39	40.22
12/08	1129.5	8469.5	60	121.32	40.15
12/08	1130	8470	60	121.3	40.13
12/08	1131	8471	60	121.28	40.11
12/08	1132	8472	60	121.26	40.09
12/08	1133.25	8473.25	60	121.25	40.08
12/08	1133.5	8473.5	60	121.22	40.05
12/08	1133.75	8473.75	60	121.21	40.04
12/08	1134	8474	60	121.2	40.03
12/08	1135	8475	60	121.2	40.03
12/08	1136	8476	60	121.18	40.01
12/08	1137	8477	60	121.16	39.99
12/08	1140	8480	60	121.14	39.97
12/08	1142	8482	60	121.11	39.94
12/08	1145	8485	60	121.09	39.92
12/08	1148	8488	60	121.08	39.91
12/08	1149	8489	60	121.07	39.9
12/08	1150	8490	60	121.06	39.89
12/08	1151	8491	60	121.05	39.88
12/08	1152	8492	60	121.04	39.87
12/08	1153	8493	60	121.03	39.86
12/08	1156	8496	60	121.02	39.85
12/08	1157	8497	60	121.01	39.84
12/08	1158	8498	60	121	39.83
12/08	1203	8503	60	120.99	39.82
12/08	1206	8506	60	120.96	39.79
12/08	1207.5	8507.5	60	120.92	39.75
12/08	1209	8509	60	122.55	41.38
12/08	1210	8510	60	122.72	41.55
12/08	1243	8543	60	123.15	41.98
12/08	1255	8555	60	123.22	42.05
12/08	1320	8580	60	123.07	41.9
12/08	1454	8674	60	123.28	42.11
12/08	1504	8684	60	123.38	42.21
12/08	1517	8697	60	123.4	42.23
12/08	1520	8700	60	123.4	42.23
12/08	1524	8704	60	123.4	42.23
12/08	1528	8708	60	123.4	42.23
12/08	1551	8731	60	123.49	42.32

Appendix C

Amador Water Agency - Consumer Confidence Report 2003

Amador Water Agency

Annual Consumer Confidence Report

For the Reporting Period January 1, 2003 to December 31, 2003

We are pleased to present this year's Annual Consumer Confidence Report. This report is designed to inform you about the quality of the water we deliver to you. Our constant goal is to provide you with a safe and dependable supply of drinking water. We want you to understand the efforts we make to continually improve the water treatment process and protect our water resources. We are committed to ensuring the quality of your water.

Water Sources

The North Fork of the Mokelumne River, located in the Sierra Nevada Mountains, is the primary water source for the Central Amador Water Project (CAWP) system, the Amador Water System (AWS), and the PG & E Tiger Creek Powerhouse system. Water supplied from rainfall and snowmelt is stored in Tiger Creek Afterbay and is pumped to the Buckhorn Water Treatment Plant. There it is treated and ready for use by the customers of Pine Grove, Pine Acres, Sunset Heights, Fairway Pines, Jackson Pines, Pioneer, Gayla Manor, Ranch House Estates, Toma Lane, Sierra Highlands, Silver Lake Pines, Ridgeway Pines, Rabb Park, and Mace Meadows. Water from the Mokelumne River is also stored in Lake Tabeaud and conveyed by canal to the Tanner Water Treatment Plant where it is treated for use by the customers of Jackson, Sutter Creek, Amador City, and Drytown. The Lone Pipeline transports raw water from the Tanner Reservoir to the Lone Water Treatment Plant where it is treated for use by the customers of Lone. Our LaMel Heights customers get their water from a single well located in the LaMel Heights Subdivision and our Lake Camanche residents get their water from three wells located in the Lake Camanche area.

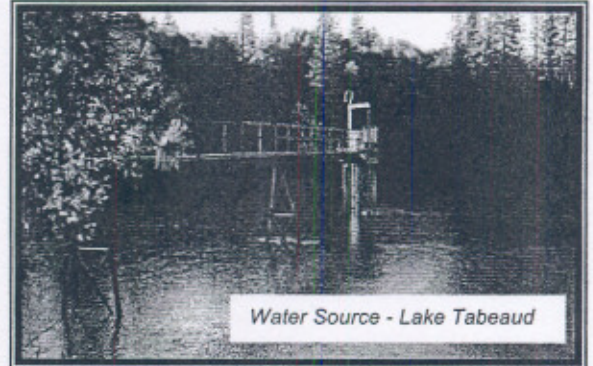

Water Source - Lake Tabeaud

Espanol - (Spanish): Este informe contiene informacion muy importante sobre su agua beber. Traduzcalo o hable con alguien que lo entienda bien.

Water Quality Assurance Testing and Monitoring

The Amador Water Agency routinely monitors for contaminants in your drinking water in accordance with Federal and State laws. Unless otherwise indicated, the results contained in this report are for the monitoring period of January 1, 2003 to December 31, 2003. This report contains results from laboratory testing, excluding contaminants that were not detected, or that were detected at a level below the State's DLR (Detection Level for purposes of Reporting). However, if the DLR is exceeded for one system, the results for that contaminant will be shown for all systems. Any questions regarding the information contained in this report can be directed to **209-223-3018**. All drinking water, including bottled drinking water, may be reasonably expected to contain small amounts of some contaminants. It is important to remember that the presence of some contaminants does not necessarily pose a health risk. More information about contaminants and potential health effects can be obtained by calling the EPA's Safe Drinking Water Hotline at 1-800-426-4791, or log on to www.epa.gov/safewater.



Test Results

The sources of drinking water (both tap water and bottled water) include rivers, lakes, streams, ponds, reservoirs, springs, and wells. As water travels over the surface of the land or through the ground, it dissolves naturally-occurring minerals and, in some cases, radioactive material, and can pick up substances resulting from the presence of animals or from human activity. Contaminants that may be present in source water include: Microbiological contaminants, such as viruses and bacteria that may come from septic systems, agricultural operations (livestock), and wildlife; Inorganic contaminants, such as salts and metals, either naturally-occurring or as a result of industrial and domestic wastewater discharges, oil and gas production, mining, farming, and storm water runoff; Pesticides and herbicides, which may come from storm-water runoff, agricultural activities and residential uses; Organic chemical contaminants, including synthetic and volatile organic chemicals, which are byproducts of petroleum and industrial processes, and may come from storm-water runoff, septic systems, and gas stations; and Radioactive contaminants, which are naturally-occurring or a result of oil and gas production and mining activities.

The State requires certain test samples to be taken of the "raw" source water; either from the well source or as it enters the treatment plant prior to disinfection or treatment. Other test samples are taken of the treated water; either as it leaves the treatment plant or at designated points in the distribution system. Testing and monitoring requirements are determined by a system's size, treatment processes, number of people served, and whether or not the area is vulnerable to certain activities that would warrant more or less frequent testing. Not all systems are required to test at the same time, or for the same contaminants. The Amador Water Agency tests for over 100 contaminants and has received "waivers" for many. The Department of Health Services has reduced or waived the testing requirements for most of the Volatile Organic Chemicals (VOC's), Synthetic Organic Chemicals (SOC's) and Unregulated Chemicals. The Amador Water Agency wholesales its treated water to other cities and districts. Some of the individual systems, districts, and cities have provided their testing information for inclusion in this report.

Service Area (District)	Microbiological Contaminants				Lead and Copper			
	Total Coliform Bacteria*	Fecal Coliform and E.coli**	# of Sites Sampled	Year Sampled	Lead Results		Copper Results	
	Violation of the MCL (see footnotes)	Violation of the MCL (see footnotes)			90% level in ppb	# of sites > 15 ppb	90% level in ppb	# of sites > 1300 ppb
AWS (Ione)	none to report	none to report	20	2001	<3.00	1	370	0
AWS (Sutter Creek, Amador City)	none to report	none to report	10	2001	4.50	0	420	0
City of Jackson	none to report	none to report	20	2002	13.00	0	530	0
First Mace Meadow Water District (Unit 1)	none to report	none to report	10	2003	<3.00	0	450	0
First Mace Meadow Water District (Unit 2)	none to report	none to report	5	2003	3.10	0	650	0
ID #1 (Pioneer, Fairway Pines)	none to report	none to report	10	2001	<3.00	0	310	0
ID #2 (Ranch House, Pine Park East, Gayla Manor, Jackson Pines)	none to report	none to report	5	2001	3.60	0	270	0
ID #3 (LaMel)	none to report	none to report	5	2001	3.35	0	980	0
ID #4 (Pine Acres)	none to report	none to report	10	2001	2.99	0	420	0
ID #5 (Silver Lake Pines, Sierra Highlands, Tiger Creek Estates)	none to report	none to report	20	2003	7.50	1	410	0
ID #6 (Mace Meadows Unit 1)	none to report	none to report	5	2002	7.05	0	435	0
ID #7 (Lake Camanche)	none to report	none to report	20	2001	3.50	0	324	0
PG&E	none to report	none to report	5	2002	10.60	0	305	0
Pine Grove CSD	none to report	none to report	20	2003	11.00	0	350	0
Rabb Park CSD	none to report	none to report	5	2003	<3.00	0	250	0
Ridgeway Pines MWC	none to report	none to report	10	2003	17.00	2	440	0
Sunset Heights CSD (see notes)	none to report	none to report	5	2002	5.00	0	200	0

Notes: Bad coliform test results in June for Sunset Heights CSD were invalidated by Ca. Dept. of Health Services. The test station was faulty and has been replaced. No violations or citations were received.

* **Total Coliform Bacteria** - Naturally present in the environment. Water systems are required to meet a strict standard for coliform bacteria. Coliform bacteria are usually harmless, but their presence in water can be an indication of disease-causing bacteria. When coliform bacteria are found, special follow-up tests are done to determine if harmful bacteria are present in the water supply. If the standard is exceeded, the water supplier must notify the public by newspaper, television or radio. MCL for systems that collect fewer than 40 samples per month is the presence of coliform bacteria in two or more samples.

** **Fecal Coliform and E.coli** - Human and animal waste. MCL - a routine sample and repeat sample that are total coliform positive, and one is also fecal coliform or E. coli positive.

Health Issues

In California, drinking water standards known as "Maximum Contaminant Levels" or "MCLs" are set in two categories, primary and secondary. Primary Standards are set to protect the public from substances in water that may be immediately harmful or affect their health if consumed for long periods of time (70+Years). Test results indicating levels above these standards require immediate action by the water supplier. Secondary Standards relate to aesthetic qualities such as taste, mineral content, odor, and clarity. These standards specify limits for substances that may influence consumer acceptance of water.

Some people may be more vulnerable to contaminants in drinking water than the general population. Immuno-compromised persons, such as persons with cancer that are undergoing chemotherapy, persons who have undergone organ transplants, people with HIV/AIDS or other immune system disorders, some elderly, and infants can be particularly at risk from infections. These people should seek advice from their health care providers about drinking water. EPA/CDC guidelines on appropriate means to lessen the risk of infection by cryptosporidium and other microbiological contaminants are available from the **Safe Drinking Water Hotline (800)426-4791**.

System Violations

Our water quality monitoring met or exceeded State and Federal Primary Drinking Water Standards. However, The Amador Water System exceeded the MCL for "color" and "iron", non-health related secondary standards. Secondary Standards relate to aesthetic qualities such as taste, mineral content, odor and clarity.

The Tanner Water Treatment Facility received Citation No. 03-10-03C-009 for failure to properly comply with the Surface Water Treatment regulations related to the reliability requirements for the disinfection process and for failure to alert the Department of Health Services to a structural failure of the inlet facility designed to assure adequate disinfection contact time.

- The hypalon tube that conveys water from the west end of the Tanner Clearwell to the east end ruptured. We began prechlorination processes along with developing a new, expanded calculation model that allowed us to meet our disinfection requirements (contact time) until a curtain could be installed to correct the situation. A public notice was issued to customers and all bacteriological testing came back as absent for coliform bacteria. Within thirty days the permanent curtain was installed.

The Action Level (AL) for Lead was exceeded at Ridgeway Pines. Infants and children who drink water containing lead in excess of the action level may experience delays in their physical or mental development. Children may show slight deficits in attention span and learning abilities. Adults who drink this water over many years may develop kidney problems or high blood pressure.

Inorganic Analyses

Contaminant	Units	MCL (AL)	DLR	PHG (MCLG)	Violation Y/N	Systems								Likely Source of Contamination		
						AWS		CAWP		LaMel		ID#7 Results				
						Results	Yr	Results	Yr	Results	Yr	Well 6	Well 9		Well 12A	Yr
Aluminum	ppb	1000	50	600	N	130	2003	75	2003	47	2002	68	68	57	2002	Erosion of natural deposits
Arsenic	ppb	50	2	N/A	N	<2	2003	<2	2002	<2	2002	2.8	2.2	4.9	2002	Erosion of natural deposits; runoff from orchards; glass and electronics production wastes
Nitrate (NO3)	ppm	45	2	N/A	N	<2.2	2003	0.49	2003	1.3	2003	10.2	8.9	5.76	2002	Runoff and leaching from fertilizer use; leaching from septic tanks and sewage; erosion of natural deposits

General Mineral & Physical ("+" indicates Secondary Standards)

Alkalinity	ppm	N/A	N/A	N/A	N/A	18	2003	18	2003	21	2002	73	53	79	2002	n/a
Aluminum +	ppb	200	N/A	N/A	N	130	2003	75	2003	47	2002	68	68	57	2002	Erosion of natural deposits; residue from some surface water treatment processes
Calcium	ppm	N/A	N/A	N/A	N/A	4.9	2003	4.1	2003	3.2	2002	17	11	13	2002	n/a
Carbonate	ppm	N/A	N/A	N/A	N/A	<5	2003	<5	2003	<5	2002	<5	<5	<5	2002	n/a
Color	Units	15	N/A	N/A	Y(AWS)	22	2003	6	2003	<3	2002	<3	<3	<3	2002	Naturally-occurring organic materials
Hardness	ppm (gpg)	N/A	N/A	N/A	N/A	20 (1.2)	2003	36 (2.1)	2003	20 (1.2)	2002	73 (4.3)	55 (3.2)	63 (3.7)	2002	Usually naturally-occurring; t
Iron +	ppb	300	100	N/A	Y(AWS)	730	2003	60	2003	<30	2002	<30	<30	<30	2002	Internal corrosion of household plumbing systems. Erosion of natural deposits; leaching from wood preservatives.
Hydroxide	ppm	N/A	N/A	N/A	N/A	<5	2003	<5	2003	<5	2002	<5	<5	<5	2002	n/a
Magnesium	ppm	N/A	N/A	N/A	N/A	1.9	2003	6.3	2003	2.9	2002	7.4	6.7	7.4	2002	n/a
Manganese +	ppb	50	20	N/A	N	40	2003	30	2003	<20	2002	<20	<20	<20	2002	Leaching from natural deposits.
pH +	Units	N/A	N/A	N/A	N/A	7.6	2003	7	2003	5.6	2002	7.1	7.1	7.6	2002	n/a
Sodium	ppm	N/A	N/A	N/A	N/A	2.7	2003	2	2003	3.65	2002	10.1	10.1	16.2	2002	Generally naturally-occurring salt present in the water.
Sulfate +	ppm	500	0.5	N/A	N/A	1.3	2003	1.1	2003	<5	2002	4.6	2.6	6.3	2002	Runoff from natural deposits; industrial waste
Zinc	ppb	5000	50	N/A	N	<20	2003	40	2003	<20	2002	60	50	60	2002	Runoff/leaching from natural deposits; industrial waste

Unregulated Chemicals (Monitoring of these chemicals helps regulatory agencies determine where certain chemicals occur and whether they need to be regulated)

Chromium VI	ppb	(N/A)	1	N/A	N	<1	2002	<1	2002	<1	2002	1.4	1.4	<1	2002	n/a
Vanadium	ppb	(50)	3	N/A	N	<3	2002	<3	2002	<3	2002	13.0	17.0	21.0	2003	n/a

Turbidity (Surface-Water Treatment Facilities Only)

Contaminant	Violation Y/N	Units	MCL	AWS				CAWP		PG & E at Tiger Creek		Likely Source of Contamination
				Tanner WTP		Ione WTP		Buckhorn WTP		Memcor Plant		
				Maximum Turbidity Recorded	% of Samples <0.5	Maximum Turbidity Recorded	% of Samples <0.5	Maximum Turbidity Recorded	% of Samples <0.5	Maximum Turbidity Recorded	% of Samples <0.5	
Turbidity	N	NTU	95%	.380	100%	.120	100%	.212	100%	.030	100%	Soil runoff

Water Source Assessment Information

An assessment of the Sutter Creek water system drinking water source (Amador Canal from Tanner Reservoir to Lake Tabeaud) was completed in May 2001. The source is considered most vulnerable to the following activities: Large animal grazing, pesticide/fertilizer storage, transfer areas in the watershed, and recreational areas adjacent to the surface water source (Lake Tabeaud).

An assessment of the lone drinking water source (lone Reservoir) was completed in February 2002. The source is considered most vulnerable to the following activities: Grazing (>5 large animals or equivalent/acre), railroads, and storm drain discharge.

Copies of the completed assessments are available at the Amador Water Agency, located at 12800 Ridge Rd, Sutter Creek.

Definition of Terms

Cal/EPA – California Environmental Protection Agency – California's environmental authority. This Cabinet level agency houses several departmental agencies committed to protecting California's air, land, and water resources.

EPA – Environmental Protection Agency - A United States governmental agency created to protect human health and safeguard the natural environment.

Grains per Gallon (gpg) – Used to determine the hardness of water based on the concentration of grains per gallon of calcium and/or magnesium. A typical aspirin equals about five grains of material. If the aspirin were dissolved in a gallon of water it would add five grains of "aspirin" to the gallon of water.

Maximum Contaminant Level Goal – The "goal" (MCLG) is the level of a contaminant in drinking water below which there is no known or expected risk to health. MCLGs allow for a margin of safety.

Million Fibers per Liter (MFL) - Million fibers per liter is a measure of the presence of asbestos fibers that are longer than 10 micrometers.

Nephelometric Turbidity Unit (NTU) - Nephelometric turbidity unit is a measure of the clarity of water. Turbidity in excess of 5 NTU is just noticeable to the average person.

Non-Detects (ND) - Laboratory analysis indicates that the contaminant is not present.

Not Required (NR) - Testing for this contaminant is not required.

Parts per trillion (ppt) or Picograms per liter - One part per trillion corresponds to one minute in 2,000,000 years, or a single penny in \$10,000,000,000.

Parts per billion (ppb) or Micrograms per liter - One part per billion corresponds to one minute in 2,000 years, or a single penny in \$10,000,000.

Parts per million (ppm) or Milligrams per liter (mg/l) - One part per million corresponds to one minute in two years, or a single penny in \$10,000.

Picocuries per liter (pCi/l) - Picocuries per liter is a measure of the radioactivity in water.

Presence/Absence (PA) – When testing to find the presence or absence of an element, mineral or contaminant, the test results will be positive (presence) or negative (absence), no quantities determined.

Primary Drinking Water Standard (PDWS) - MCLs, along with monitoring, reporting and water treatment requirements for contaminants that affect health.

Public Health Goal (PHG) – The level of a contaminant in drinking water below which there is no known or expected risk to health. PHGs are set by the California Environmental Protection Agency.

Regulatory Action Level - The concentration of a contaminant, which, if exceeded, triggers treatment or other requirements, which a water system must follow.

Secondary Drinking Water Standards (SDWS) – MCLs for contaminants that relate to aesthetic qualities such as taste, odor, mineral content and appearance.

Treatment Technique (TT) - Treatment technique is a required process intended to reduce the level of a contaminant in drinking water.

Turbidity (NTU) – Turbidity is a measure of the cloudiness of the water. We monitor it because it is a good indicator of water quality. High turbidity can hinder the effectiveness of disinfectants.

Waivers (W) – Testing for particular contaminants has been waived by the Department of Health Services for a period of time.

Water Purveyors' Contact Information

Amador Water Agency 12800 Ridge Road Sutter Creek CA 95685 Customer Service:(209)223-3018 Emergency: (209)223-3018	City of Jackson 33 Broadway Jackson CA 95642 Customer Service:(209)223-1646 Emergency: (209)223-0219	First Mace Meadows Water Assoc. PO Box 85 Pioneer CA 95666 Customer Service:(209)295-3132 Emergency: (209)295-3132
Pine Grove CSD PO Box 367 Pine Grove CA 95665 Customer Service: (209)296-7188 Emergency: (209)296-7188	Rabb Park CSD PO Box 1105 Pioneer CA 95666 Customer Service: (209)295-7430 Emergency: (209)295-4724	Sunset Heights CSD 17910 Sharon Court Pine Grove CA 95665 Customer Service: (209)296-2528 Emergency: (209)296-4124, 296-2528

Amador Water Agency – Board of Directors

Heinz Hamann, District I - Jackson area

John Swift, District II – Lake Camanche & lone area

Mike Johnson, District III – Pioneer area

Dan Brown, District IV – Sutter Creek & Pine Grove area

Terence Moore, District V – Plymouth, Fiddletown & Sunset Heights area

The Amador Water Agency's Board of Directors meetings are scheduled for 9:00 a.m. every 2nd and 4th Thursday of the month at the Agency office located at 12800 Ridge Road, Sutter Creek, California.

THANK YOU!

Thank you for allowing us to continue providing your family, employees, and customers with clean, high quality water this year. We at the Amador Water Agency work around-the-clock to provide top-quality water to every tap. We ask that everyone help protect our water resources, which are the heart of our community, our way of life, and our children's future.

12/08	1633	8773	60	123.5	42.33
12/08	1704	8804	60	123.55	42.38
12/08	1810	8870	60	123.68	42.51
12/09	930	9790	60	123.2	42.03
12/09	1015	9835	60	123.25	42.08
12/09	1020	9840	60	124.6	43.43
12/09	1029	9849	60	125.05	43.88
12/09	1050	9870	60	125.28	44.11
12/09	1108	9888	60	125.32	44.15
12/09	1117	9897	60	125.36	44.19
12/09	1130	9910	60	125.35	44.18
12/09	1200	9940	60	125.5	44.33
12/09	1236	9976	60	125.58	44.41
12/09	1256	9996	60	125.63	44.46
12/09	1308	10008	60	125.65	44.48

Ione Pumping Test Data
Pumped Well is H1
Recovery in H1

Date	Time	Cumulative Time (min)	Flow Rate (gpm)	DTW (ft)	Drawdown (ft)
12/09	1313	0.0	0	123.6	42.43
12/09	1313	0.2	0	123.83	42.66
12/09	1313	0.3	0	123.95	42.78
12/09	1313	0.5	0	124.01	42.84
12/09	1313	0.7	0	124.1	42.93
12/09	1314	0.9	0	124.08	42.91
12/09	1314	1.8	0	124.08	42.91
12/09	1315	2.3	0	123.95	42.78
12/09	1315	2.6	0	123.95	42.78
12/09	1316	2.8	0	123.95	42.78
12/09	1316	3.2	0	123.92	42.75
12/09	1316	3.6	0	123.92	42.75
12/09	1317	4.1	0	123.89	42.72
12/09	1317	4.5	0	123.87	42.7
12/09	1319	6.3	0	123.85	42.68
12/09	1319	6.8	0	123.84	42.67
12/09	1320	7.3	0	123.84	42.67
12/09	1322	8.8	0	123.82	42.65
12/09	1325	12.6	0	123.77	42.6
12/09	1331	18	0	123.76	42.59
12/09	1339	26	0	123.71	42.54
12/09	1352	39	0	123.61	42.44
12/09	1359	46	0	123.6	42.43
12/09	1404	51	0	123.6	42.43
12/09	1434	81	0	123.48	42.31
12/09	1504	111	0	123.31	42.14
12/09	1609	176	0	123.15	41.98
12/09	1722	249	0	122.9	41.73
12/10	720	1087	0	120.85	39.68
12/10	729	1096	0	120.96	39.79
12/10	1304	1431	0	120.34	39.17
12/10	1501	1548	0	120.22	39.05
12/11	906	2633	0	118.38	37.21
12/11	917	2642	0	118.38	37.21
12/12	756	4001	0	116.54	35.37
12/13	958	5563	0	114.5	33.33
12/14	1516	7321	0	112.44	31.27
12/15	839	8396	0	111.38	30.21
12/19	1312	14429	0	110.94	29.77
12/24	804	21321	0	104.71	23.54
12/29	1145	28742	0	96.54	15.37
01/08	818	42935	0	87.19	6.02

APPENDIX C

Pumping Test Graphical Results

Well M1
Constant Yield and Drawdown Test - 12/13/03
Ione Casino Site, Plymouth, California

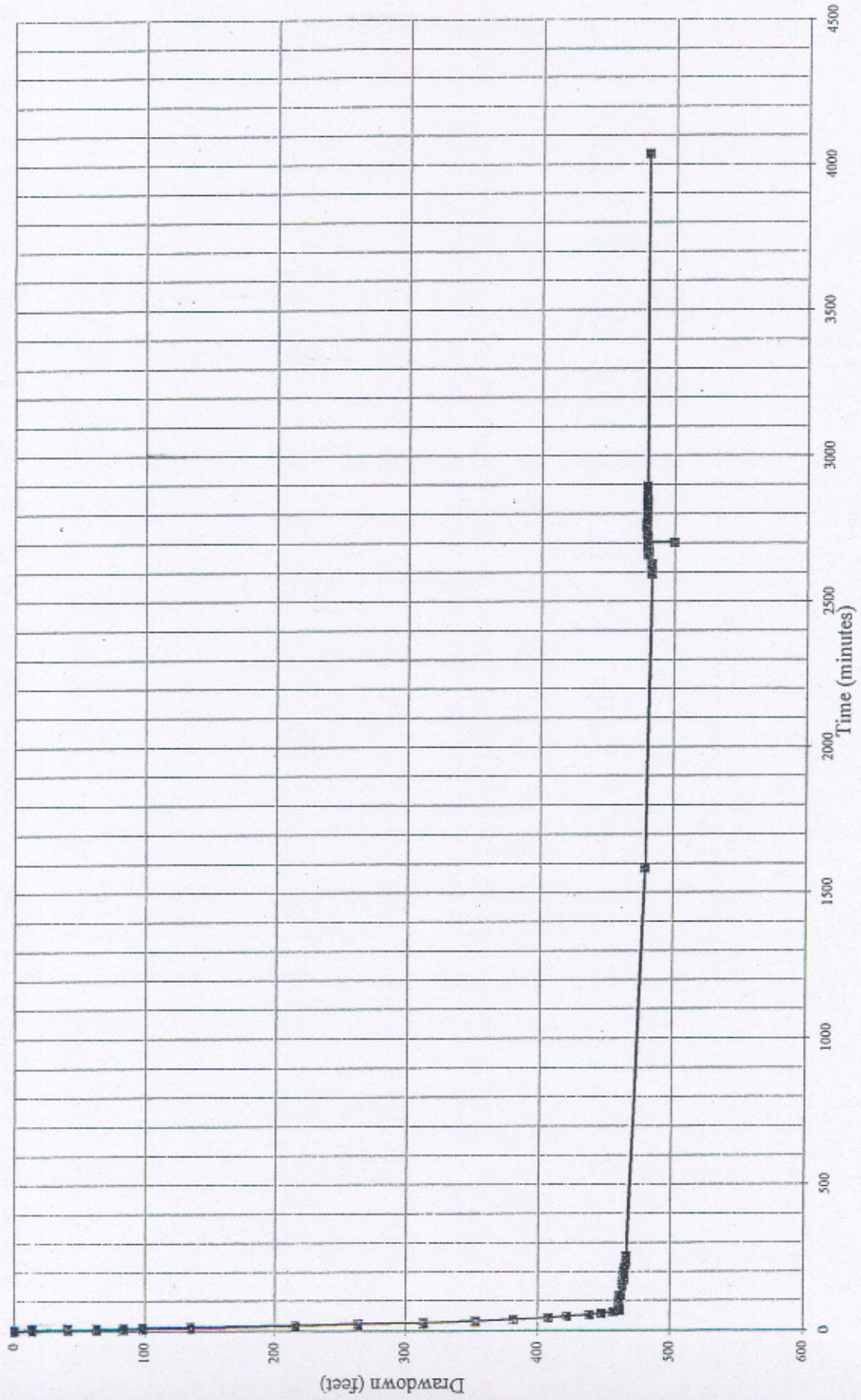

Well M1.
Constant Yield and Drawdown Test - Recovery Phase - 12/16/03
Ione Casino Site, Plymouth, California

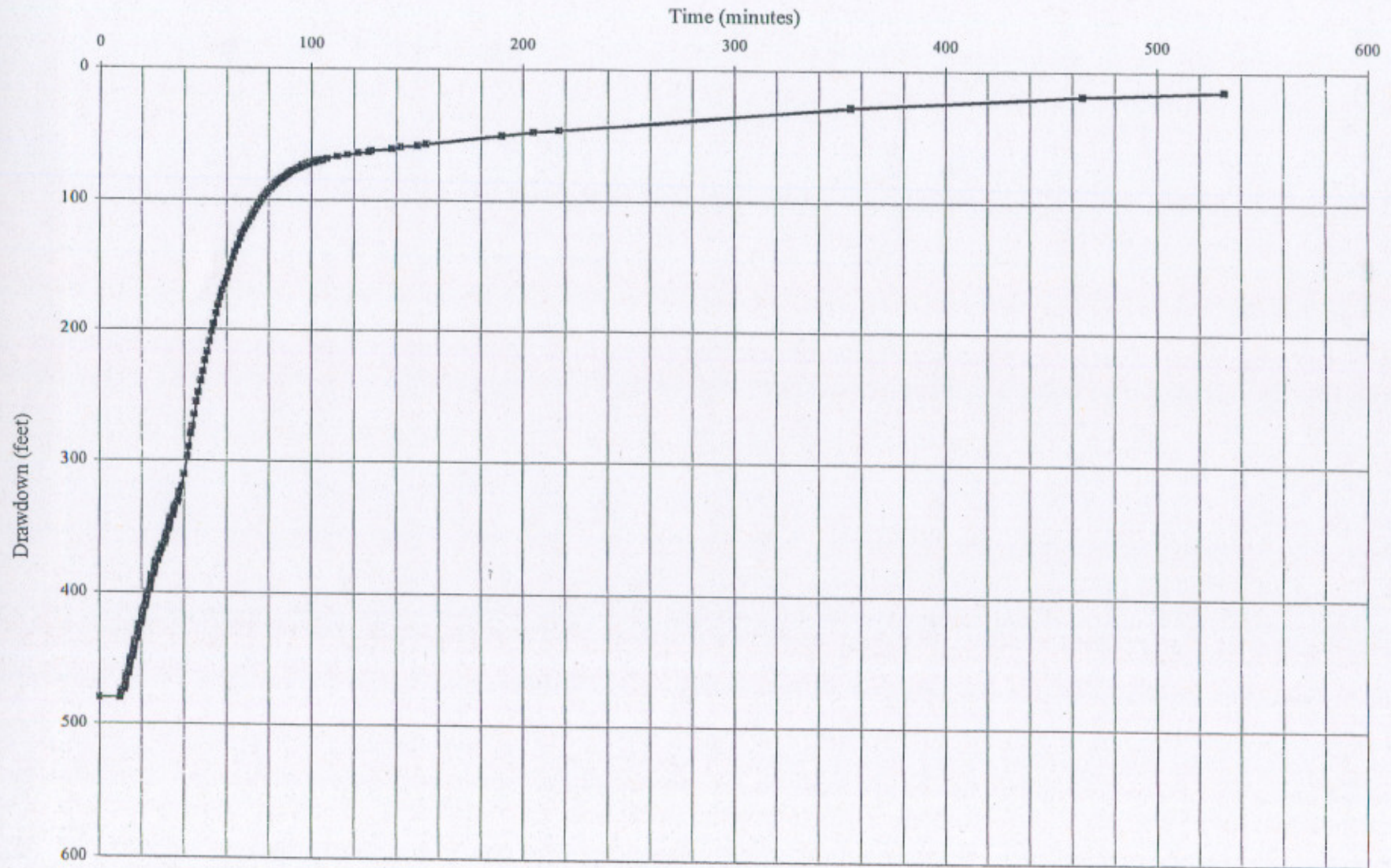

AEG, Inc.
578 E Street
Lincoln, California
95648

Pumping test analysis
Recovery method after
THEIS & JACOB
Confined aquifer

Date: 8-01-04

Page 1

Project: Ione Casino Site

Evaluated by: WLK

Pumping Test No.

Test conducted on: 7-12-2004

Well M3

Discharge 73.94 U.S.gal/min

Pumping test duration: 6640.00 min

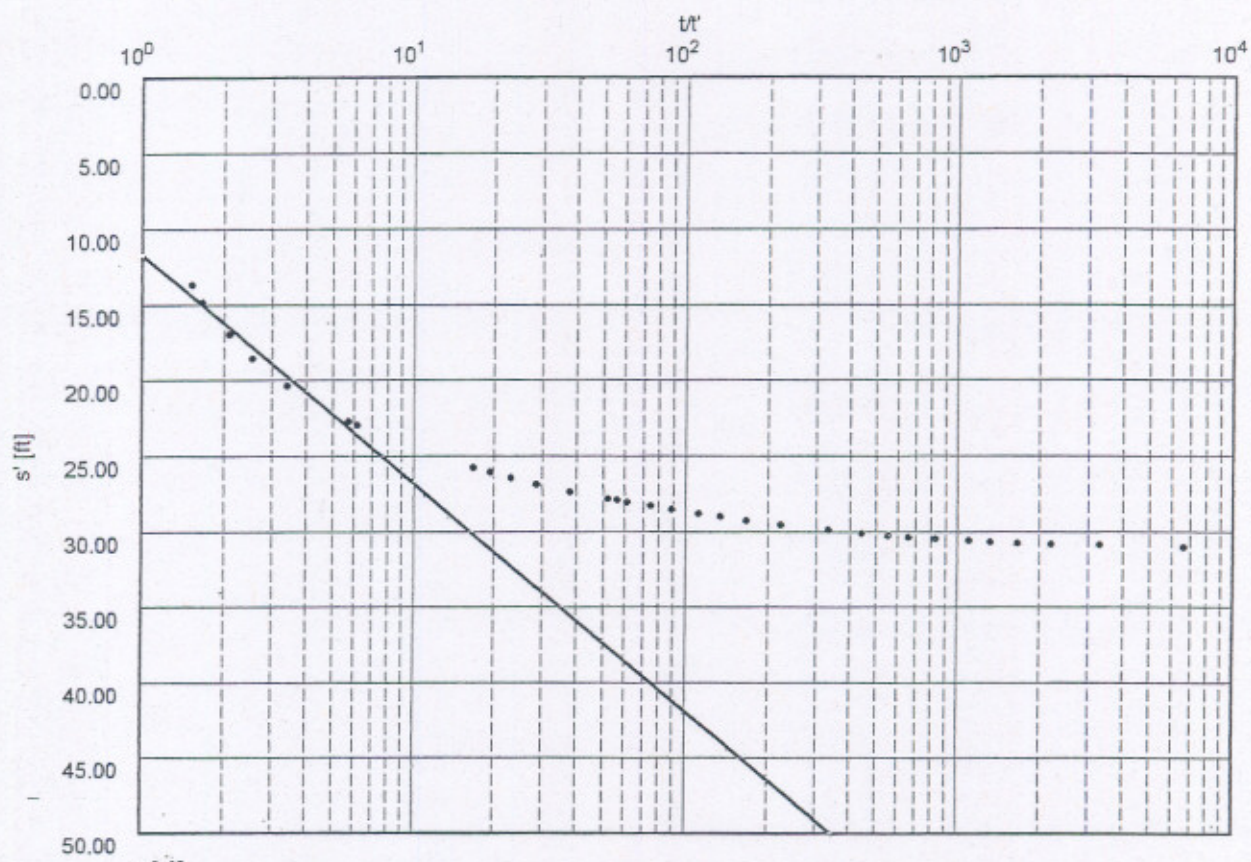

• M3

Transmissivity [ft²/min]: 1.19×10^{-1}

Hydraulic conductivity [ft/min]: 2.99×10^{-3}

Aquifer thickness [ft]: 40.00

Well M3
Step Drawdown Test - Drawdown and Recovery - 07/06/04
Ione Casino Site, Plymouth, California

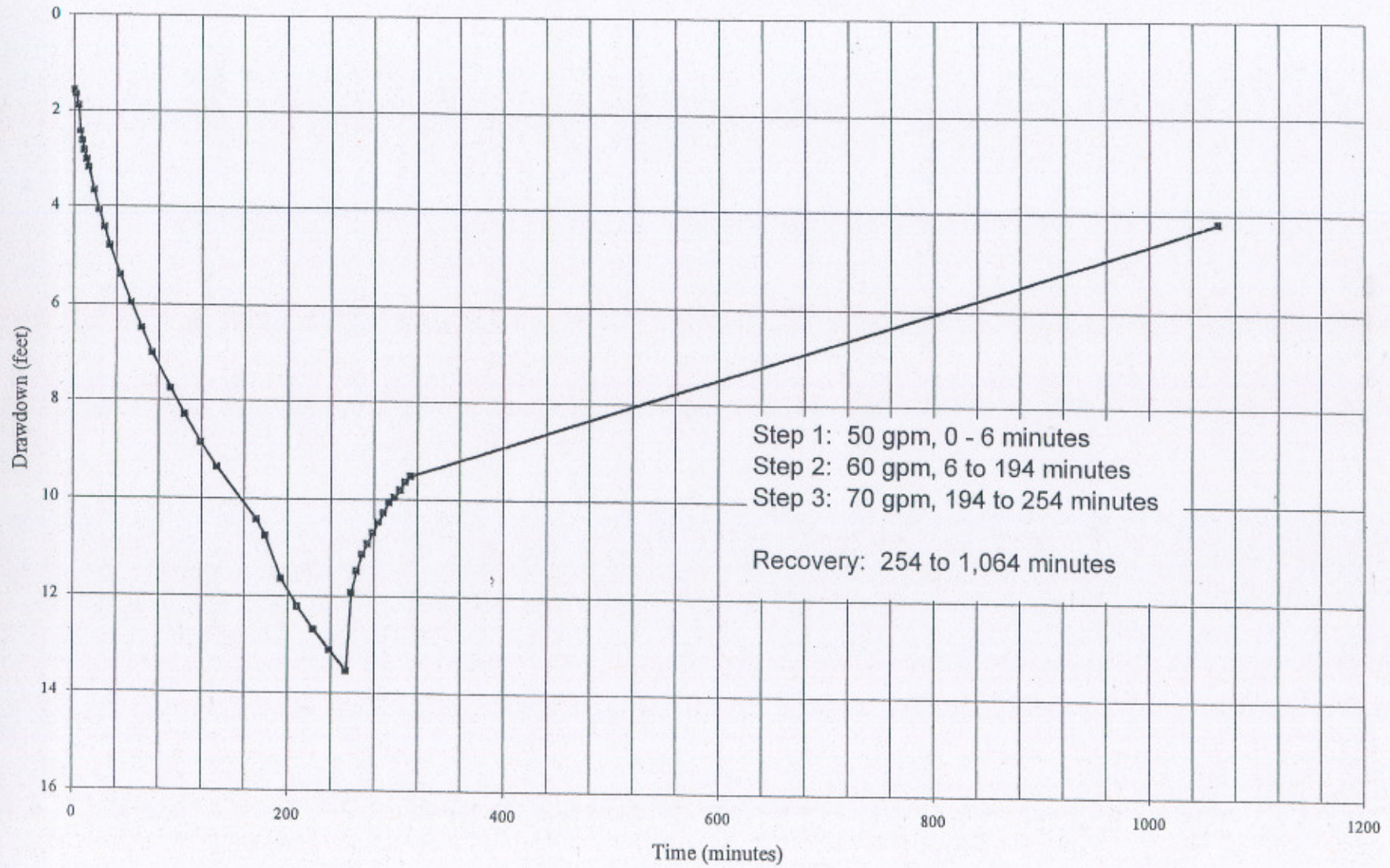

Well M3
Constant Rate Test - 07/07/04
Ione Casino Site, Plymouth, California

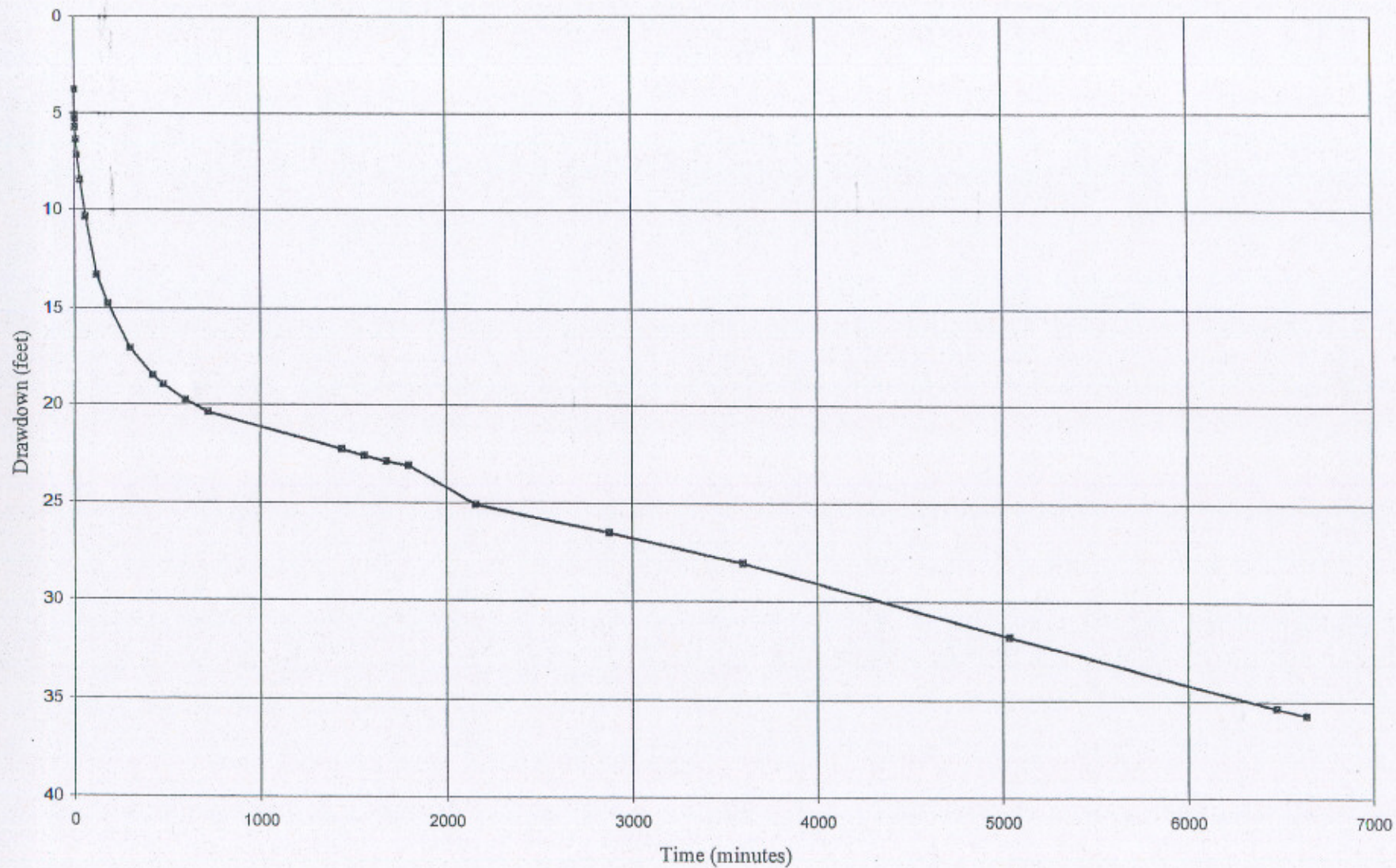

8/1/2004

Well M3
Constant Rate Test - Recovery Phase - 07/21/04
Ione Casino Site, Plymouth, California

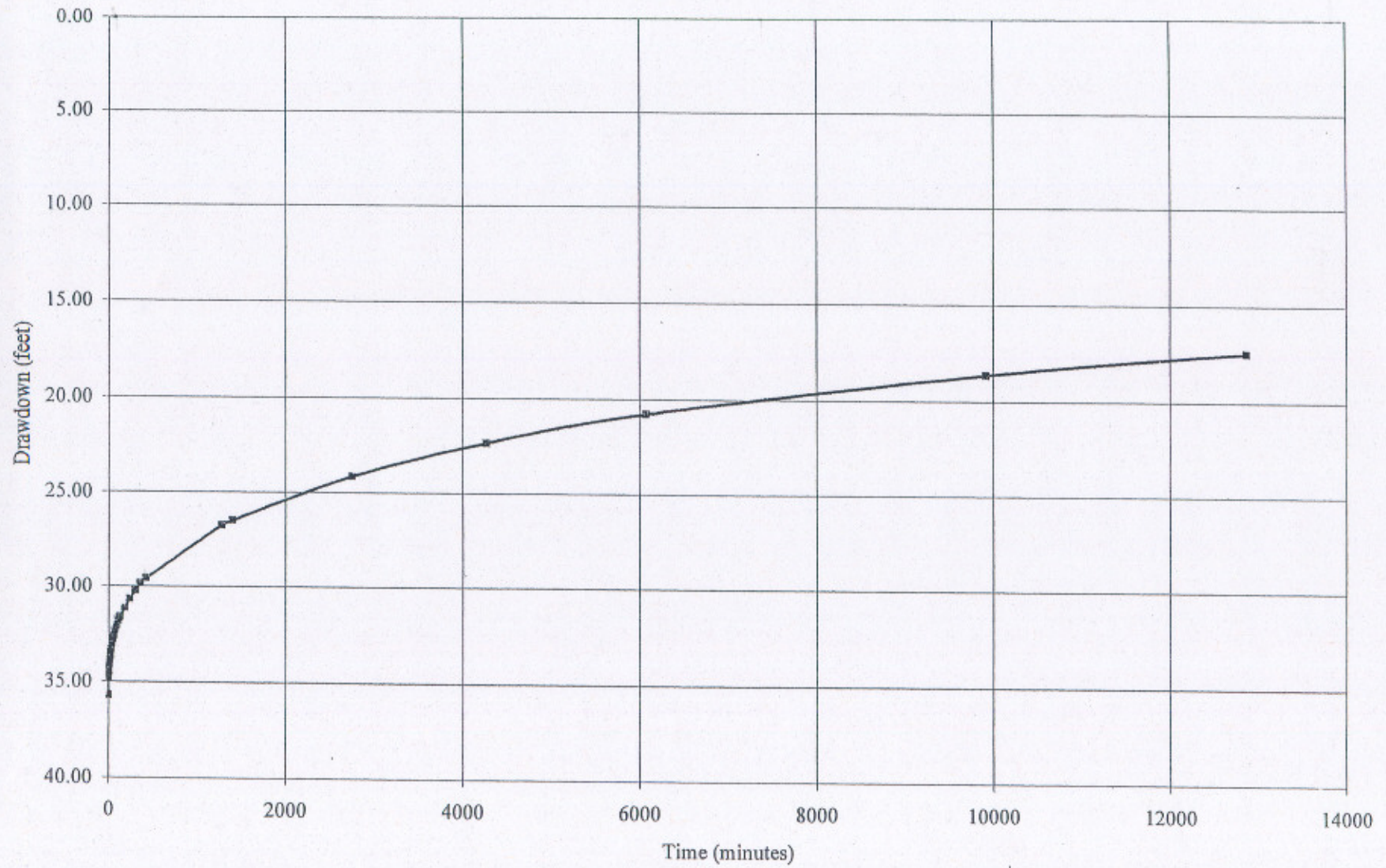

Well M3
Constant Rate Test - Drawdown at M-3 (pumped) and M-2 (obs)
Ione Casino Site, Plymouth, California



AEG, Inc.
 578 E Street
 Lincoln, California
 95648

Pumping test analysis
 Recovery method after
 THEIS & JACOB
 Confined aquifer

Date: 08-01-04 Page 1

Project: Lone Casino Site

Evaluated by: WLK

Pumping Test No.

Test conducted on: 12-09-03

Well H1

Discharge 60.00 U.S.gal/min

Pumping test duration: 10008.00 min

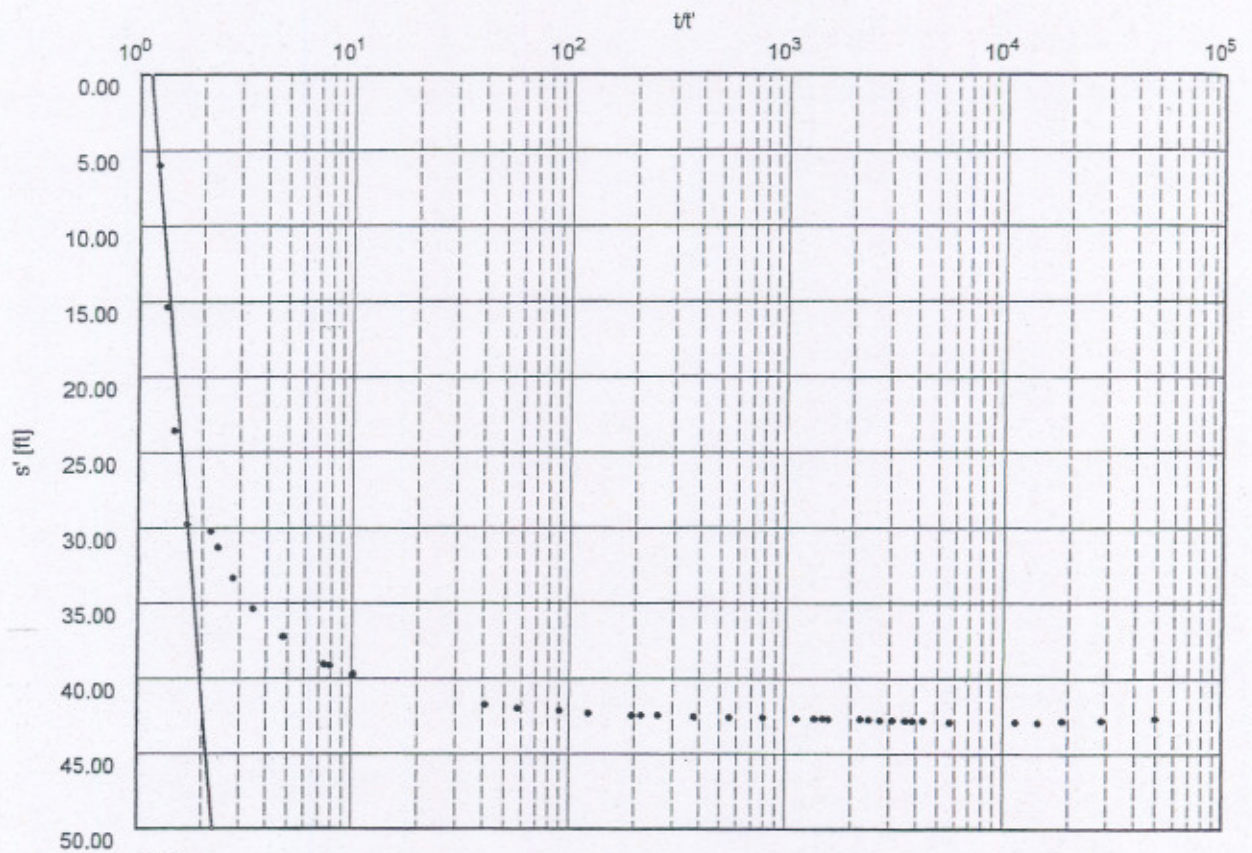

• H1

Transmissivity [ft²/min]: 9.03×10^{-3}

Hydraulic conductivity [ft/min]: 4.51×10^{-4}

Aquifer thickness [ft]: 20.00

Well H1
Constant Rate Test - 12/02/03
Ione Casino Site, Plymouth, California

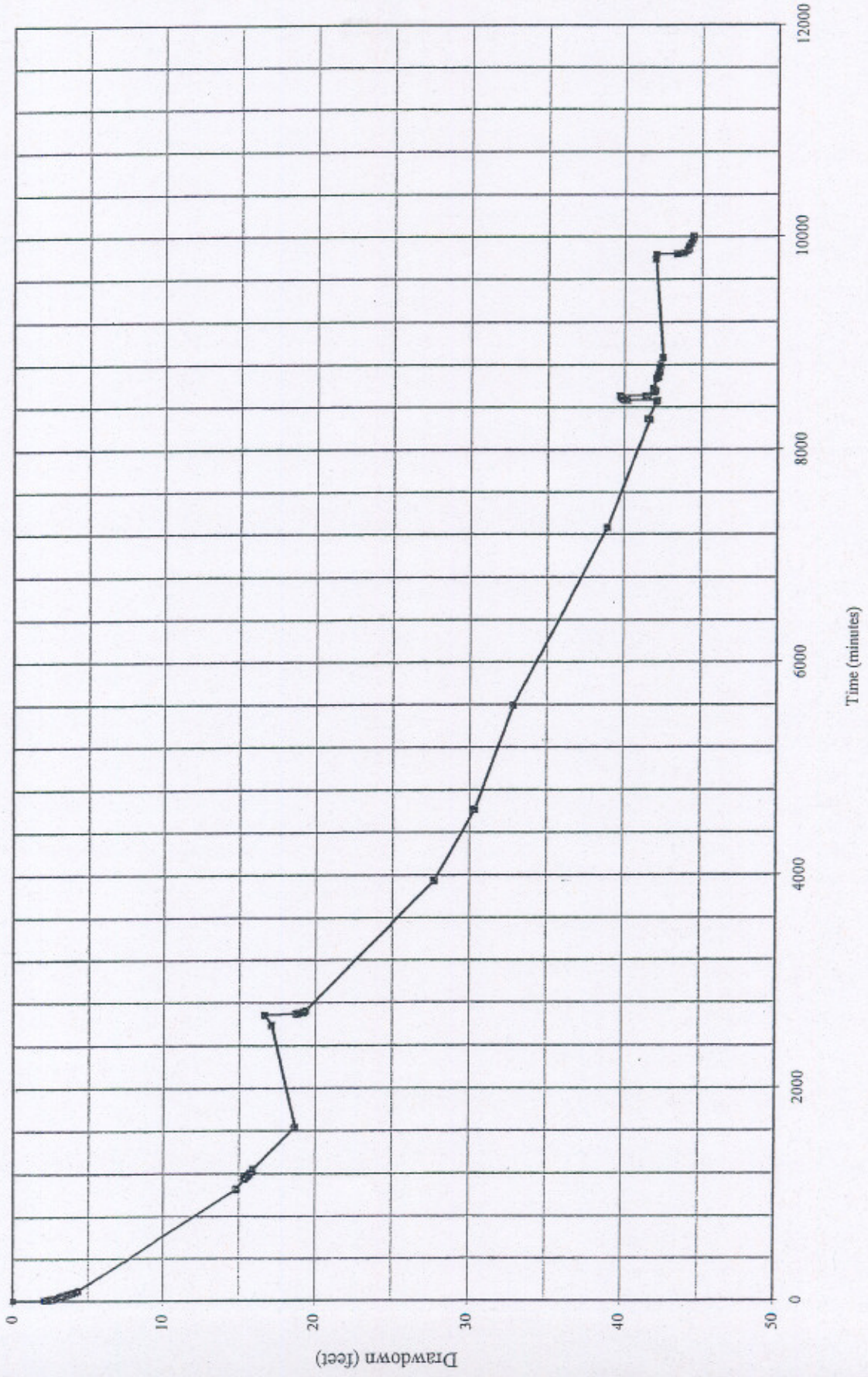

Well H1
Constant Rate Test - Recovery Phase - 12/09/03
Ione Casino Site, Plymouth, California

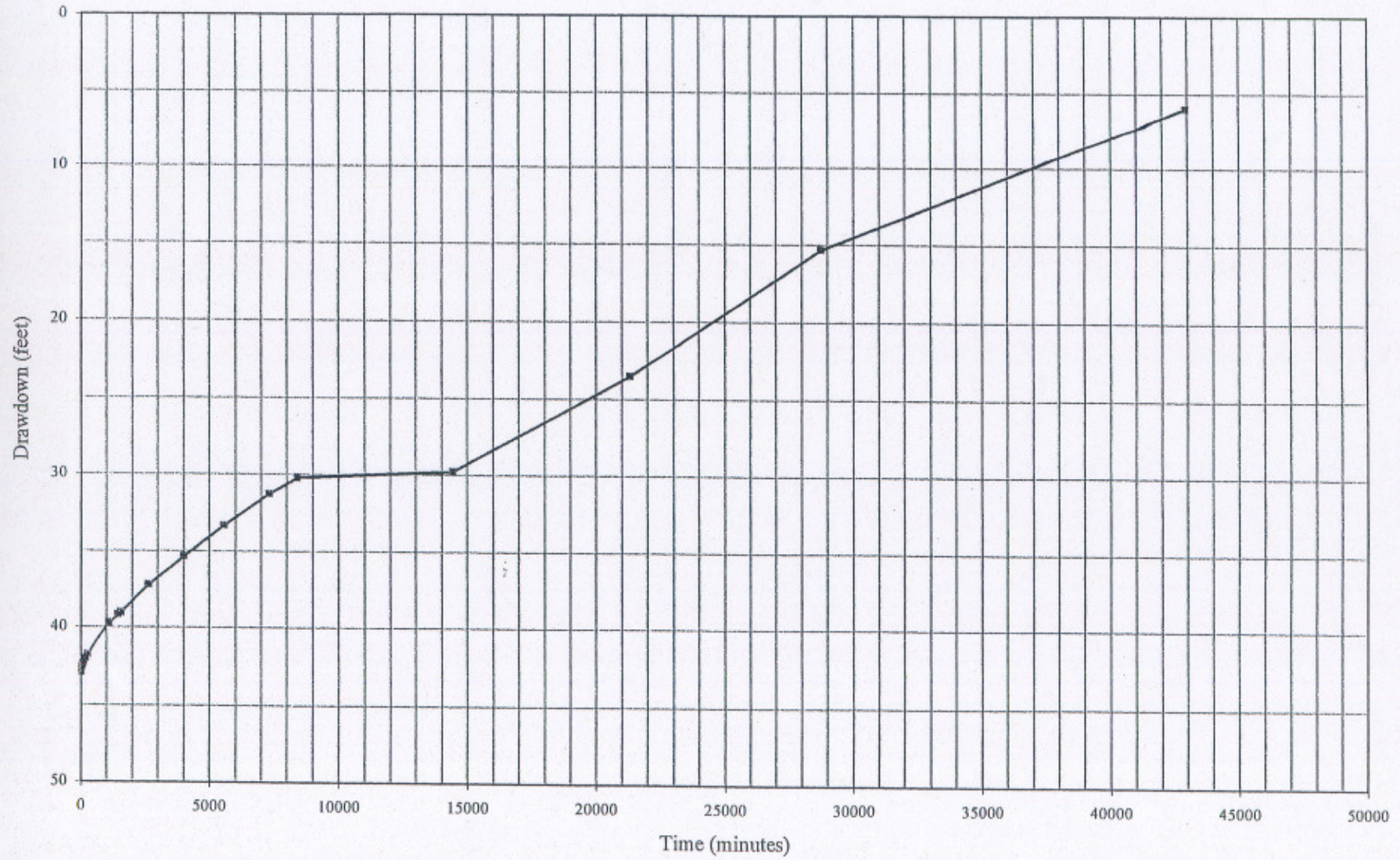

APPENDIX D

Calculation of Long-Term Well Yield

Calculation of Long-Term Well Yield Well M1

Test Methodology:

Pumped dynamic level to top of perforated PVC, reduced flow rate until dynamic level stabilized, and continued pumping.

Test Results:

Static water level at test start (fbtoc):	52.7
Test duration (hours):	67.3
Test flow rate (gpm):	17.0
Duration of stable water levels (hours):	40.9
Maximum drawdown at end of test (feet):	480.4

Analysis

Extrapolated drawdown to 200 days (feet):	480.4
Specific capacity at 200 days (gpm/ft):	0.0354
Top of perforated PVC (fbgs):	540
Total available drawdown (feet):	487.3
Safety Factor Multiplier	0.7
Safe available drawdown (feet):	341.11

Long-term well yield (gpm) = specific capacity at 200 days * safe available drawdown

Long-term well yield (gpm): 12.1

Comments:

Flow rate was reduced to 17 gpm to achieve a stable dynamic level. Specific capacity at test end is equivalent to specific capacity at 200 days.

Drawdown extrapolated to 200 days

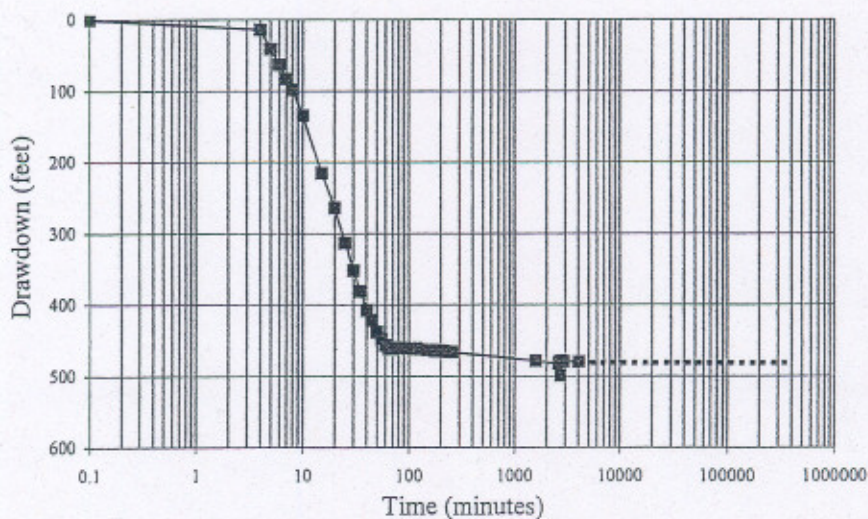

Calculation of Long-Term Well Yield Well M3

Test Methodology:

Pumped dynamic level to top of perforated PVC, reduced flow rate in an attempt to stabilize the dynamic level.

Test Results:

Static water level at test start (fbtoc):	42.4
Test duration (hours):	99.1
Test flow rate (gpm):	51.0
Duration of stable water levels (hours):	Did not stabilize
Maximum drawdown at end of test (feet):	20.8

Analysis

Extrapolated drawdown to 200 days (feet):	50.0
Specific capacity at 200 days (gpm/ft):	1.0200
Top of perforated PVC (fbgs):	180
Total available drawdown (feet):	137.6
Safety Factor Multiplier	0.30
Safe available drawdown (feet):	41.289

Long-term well yield (gpm) = specific capacity at 200 days * safe available drawdown

Long-term well yield (gpm): 42.1

Comments:

Very poor recovery during the constant rate test suggests that the fractures that store and transmit water are being dewatered during pumping; therefore a safety factor of 70% was used to calculate safe available drawdown.

Drawdown extrapolated to 200 days

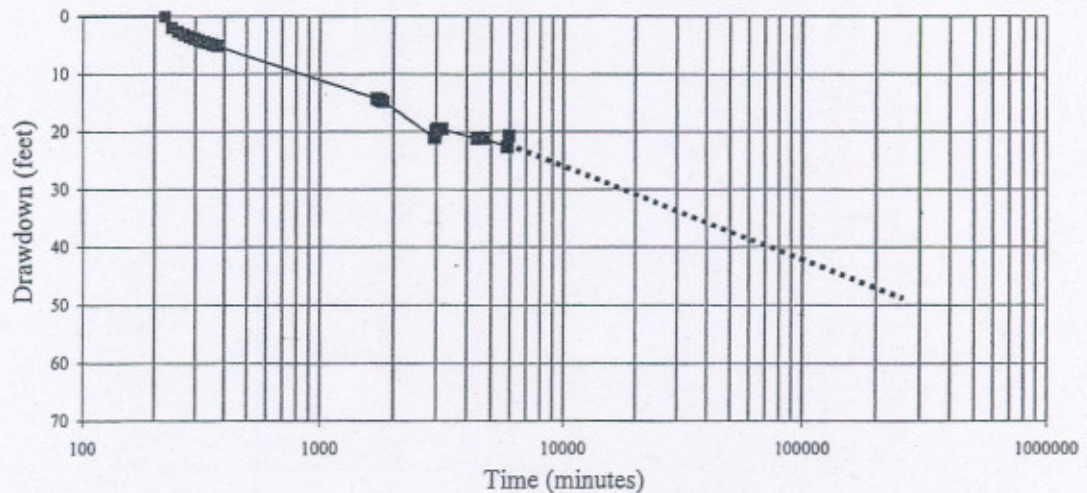

Calculation of Long-Term Well Yield Well H1

Test Methodology:

Constant rate test

Test Results:

Static water level at test start (fbtoc):	81.2
Test duration (hours):	166.8
Test flow rate (gpm):	60.0
Duration of stable water levels (hours):	Did not stabilize
Max drawdown end of test (feet):	44.5

Analysis

Extrapolated drawdown to 200 days	105.0
Specific capacity at 200 days (gpm/ft):	0.5714
Top of main water strike (fbgs):	200
Total available drawdown (feet):	118.8
Safety factor multiplier:	0.6
Safe available drawdown (feet):	71.298

Long-term well yield (gpm) = specific capacity at 200 days * safe available drawdown

Long-term well yield (gpm): 40.7

Comments:

Safety factor increased due to poor recovery characteristics, concern about cascade from upper water strike at 105 to 107' bgs.

Boundary condition apparent at ~ 3000 minutes, at a drawdown of ~ 20 feet.

SWL at test start = ~ 81 feet, so boundary occurs at 101 feet.

Very close to water strike at 105 feet reported by drillers,
so appears boundary is due to dewatering of upper water strike.

Drawdown extrapolated to 200 days

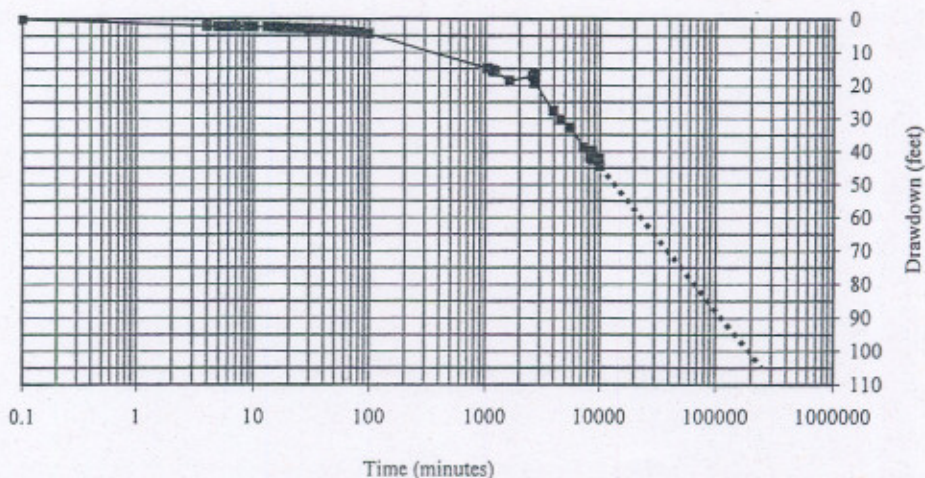

APPENDIX E

Analytical Laboratory Report



**ANALYTICAL
ENVIRONMENTAL
SERVICES**

2021 N Street, Suite 200
Sacramento, CA 95814
<http://www.analyticalcorp.com>
(916) 447-3479 • Fax (916) 447-1665

Fax

To: Earl Stephens

From: Paul Hann, Associate

Fax No: 916-645-6098

Date:

Pages: 7 Including Cover

Urgent For Review Please Comment Please Reply For Your Information

Earl,

Here's the water quality data for the Mautlich M3 sample we took a couple of weeks ago.

Paul Hann

CALIFORNIA LABORATORY SERVICES

3249 Fitzgerald Road Rancho Cordova, CA 95742

July 23, 2004

CLS Work Order #: CNG0325
COC #: 58730

Paul Hann
AES
2021 N Street Ste. 200
Sacramento, CA 95814

Project Name: Ione Water Sampling

Enclosed are the results of analyses for samples received by the laboratory on 07/12/04 13:15. Samples were analyzed pursuant to client request utilizing EPA or other ELAP approved methodologies. I certify that the results are in compliance both technically and for completeness.

Analytical results are attached to this letter. Please call if we can provide additional assistance.

Sincerely,

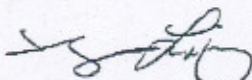

James Liang, Ph.D.
Laboratory Director

CA DOHS ELAP Accreditation/Registration number 1233.

CALIFORNIA LABORATORY SERVICES

07/23/04 16:02

AES
2021 N Street Ste. 200
Sacramento, CA 95814

Project: Ione Water Sampling
Project Number: 203525
Project Manager: Paul Hann

CLS Work Order #: CNG0325
COC #: 58730

CAM 17 Metals

Analyte	Result	Reporting Limit	Units	Dilution	Batch	Prepared	Analyzed	Method	Notes
Matulich M3 (CNG0325-01) Water Sampled: 07/12/04 11:30 Received: 07/12/04 13:15									
Arsenic	ND	5.0	µg/L	1	CN05448	07/13/04	07/13/04	EPA 200.8	
Lead	ND	5.0	"	"	"	"	"	"	
Selenium	ND	5.0	"	"	"	"	"	"	
Thallium	ND	10	"	"	"	"	"	"	
Antimony	ND	50	"	"	CN05450	07/13/04	07/13/04	EPA 200.7	
Barium	ND	20	"	"	"	"	"	"	
Beryllium	ND	5.0	"	"	"	"	"	"	
Cadmium	ND	10	"	"	"	"	"	"	
Cobalt	ND	20	"	"	"	"	"	"	
Chromium	ND	20	"	"	"	"	"	"	
Copper	ND	20	"	"	"	"	"	"	
Molybdenum	ND	20	"	"	"	"	"	"	
Nickel	ND	20	"	"	"	"	"	"	
Silver	ND	10	"	"	"	"	"	"	
Vanadium	ND	20	"	"	"	"	"	"	
Zinc	ND	20	"	"	"	"	"	"	
Mercury	ND	0.20	"	"	CN05454	07/13/04	07/14/04	EPA 245.1	

CA DOHS ELAP Accreditation/Registration Number 1233

3249 Fitzgerald Road Rancho Cordova, CA 95742

www.californialab.com 916-638-7301

Fax: 916-638-4510

CALIFORNIA LABORATORY SERVICES

07/23/04 16:02

AES
2021 N Street Ste. 200
Sacramento, CA 95814

Project: Ione Water Sampling
Project Number: 203525
Project Manager: Paul Hann

CLS Work Order #: CNG0325
COC #: 58730

Conventional Chemistry Parameters by APHA/EPA Methods

Analyte	Result	Reporting Limit	Units	Dilution	Batch	Prepared	Analyzed	Method	Notes
Matulich M3 (CNG0325-01) Water Sampled: 07/12/04 11:30 Received: 07/12/04 13:15									
Total Alkalinity	220	5.0	mg/L	1	CN05543	07/15/04	07/15/04	EPA 310.1	
Bicarbonate as CaCO ₃	220	5.0	"	"	"	"	"	"	
Carbonate as CaCO ₃	ND	5.0	"	"	"	"	"	"	
Hydroxide as CaCO ₃	ND	5.0	"	"	"	"	"	"	
Chloride	12	0.50	"	"	CN05446	07/13/04	07/13/04	EPA 300.0	
Fluoride	0.21	0.10	"	"	"	"	"	"	
Nitrate as NO ₃	ND	2.0	"	"	"	"	"	"	
Sulfate as SO ₄	60	2.5	"	5	"	"	07/13/04	"	
Specific Conductance (EC)	480	1.0	µmhos/cm	1	CN05545	07/15/04	07/15/04	EPA 120.1	
Methylene Blue Active Substances	ND	0.10	mg/L	"	CN05471	07/13/04	07/13/04	EPA 425.1	
Calcium	60	1.0	"	"	CN05376	07/15/04	07/16/04	200.7/2340B	
Magnesium	32	1.0	"	"	"	"	"	"	
Potassium	ND	1.0	"	"	"	"	"	"	
Sodium	11	1.0	"	"	"	"	"	"	
Hardness as CaCO ₃	280	1.0	"	"	"	"	"	"	
pH	6.90		pH Units	"	CN05437	07/12/04	07/12/04	EPA 150.1	
Total Dissolved Solids	360	10	mg/L	"	CN05499	07/14/04	07/14/04	EPA 160.1	

CA DOHS ELAP Accreditation/Registration Number 1233

3249 Fitzgerald Road Rancho Cordova, CA 95742 www.californialab.com 916-638-7301 Fax: 916-638-4510

CALIFORNIA LABORATORY SERVICES

07/23/04 16:02

AES 2021 N Street Ste. 200 Sacramento, CA 95814	Project: Ionic Water Sampling Project Number: 203525 Project Manager: Paul Hann	CLS Work Order #: CNG0325 COC #: 58730
---	---	---

Microbiological Parameters by APHA Standard Methods

Analyte	Result	Reporting Limit	Units	Dilution	Batch	Prepared	Analyzed	Method	Notes
Matulich M3 (CNG0325-01) Water Sampled: 07/12/04 11:30 Received: 07/12/04 13:15									
Total Coliforms	Absent		N/A	1	CN05465	07/12/04	07/13/04	SM 9223	
E. Coli	Absent		"	"	"	"	"	"	

CA DOHS ELAP Accreditation/Registration Number 1233

CALIFORNIA LABORATORY SERVICES

07/23/04 16:02

AES
2021 N Street Ste. 200
Sacramento, CA 95814

Project: Ione Water Sampling
Project Number: 203525
Project Manager: Paul Hann

CLS Work Order #: CNG0325
COC #: 58730

Notes and Definitions

BT-02 Absent

QM-08 The spike recovery was outside acceptance limits for the LCS or LCSD. The batch was accepted based on acceptable MS/MSD recoveries & RPD's.

DET Analyte DETECTED

ND Analyte NOT DETECTED at or above the reporting limit

NR Not Reported

dry Sample results reported on a dry weight basis

RPD Relative Percent Difference

CALIFORNIA LABORATORY SERVICES

3249 Fitzgerald Road Rancho Cordova, CA 95742

November 12, 2003

CLS Work Order #: CMJ1093
COC #: 35548

Joel Kiff
KIFF Analytical
2795 Second St. Suite 300; Suite D
Davis, CA 95616

Project Name: Ione

Enclosed are the results of analyses for samples received by the laboratory on 10/29/03 18:40. Samples were analyzed pursuant to client request utilizing EPA or other ELAP approved methodologies. I certify that the results are in compliance both technically and for completeness.

Analytical results are attached to this letter. Please call if we can provide additional assistance.

Sincerely,

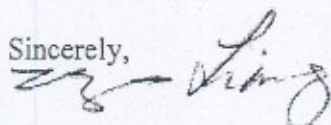

James Liang, Ph.D.
Laboratory Director

CA DOHS ELAP Accreditation/Registration number 1233

CALIFORNIA LABORATORY SERVICES

11/12/03 15:35

KIFF Analytical
2795 Second St. Suite 300; Suite D
Davis, CA 95616

Project: Ione
Project Number: [none]
Project Manager: Joel Kiff

CLS Work Order #: CMJ1093
COC #: 35548

CAM 17 Metals

Analyte	Result	Reporting Limit	Units	Dilution	Batch	Prepared	Analyzed	Method	Note
Matulich (CMJ1093-01) Water Sampled: 10/29/03 14:05 Received: 10/29/03 18:40									
Arsenic	ND	5.0	µg/L	1	CJ33117	10/31/03	11/10/03	EPA 6020	
Lead	ND	5.0	"	"	"	"	"	"	
Selenium	ND	5.0	"	"	"	"	"	"	
Thallium	ND	10	"	"	"	"	"	"	
Antimony	ND	50	"	"	CJ33119	10/31/03	11/01/03	EPA 6010B	
Barium	50	20	"	"	"	"	"	"	
Beryllium	ND	5.0	"	"	"	"	"	"	
Cadmium	ND	10	"	"	"	"	"	"	
Cobalt	ND	20	"	"	"	"	"	"	
Chromium	ND	20	"	"	"	"	"	"	
Copper	440	20	"	"	"	"	"	"	
Molybdenum	ND	20	"	"	"	"	"	"	
Nickel	ND	20	"	"	"	"	"	"	
Silver	ND	10	"	"	"	"	"	"	
Vanadium	ND	20	"	"	"	"	"	"	
Zinc	60	20	"	"	"	"	"	"	
Mercury	ND	0.20	"	"	CK30323	11/03/03	11/04/03	EPA 7470	
Cistern (CMJ1093-02) Water Sampled: 10/29/03 15:10 Received: 10/29/03 18:40									
Arsenic	ND	5.0	µg/L	1	CJ33117	10/31/03	11/10/03	EPA 6020	
Lead	ND	5.0	"	"	"	"	"	"	
Selenium	ND	5.0	"	"	"	"	"	"	
Thallium	ND	10	"	"	"	"	"	"	
Antimony	ND	50	"	"	CJ33119	10/31/03	11/01/03	EPA 6010B	
Barium	ND	20	"	"	"	"	"	"	
Beryllium	ND	5.0	"	"	"	"	"	"	
Cadmium	ND	10	"	"	"	"	"	"	
Cobalt	ND	20	"	"	"	"	"	"	
Chromium	ND	20	"	"	"	"	"	"	
Copper	ND	20	"	"	"	"	"	"	
Molybdenum	ND	20	"	"	"	"	"	"	
Nickel	ND	20	"	"	"	"	"	"	
Silver	ND	10	"	"	"	"	"	"	
Vanadium	ND	20	"	"	"	"	"	"	
Zinc	ND	20	"	"	"	"	"	"	

CA DOHS ELAP Accreditation/Registration Number 1233

CALIFORNIA LABORATORY SERVICES

11/12/03 15:35

KIFF Analytical
2795 Second St. Suite 300; Suite D
Davis, CA 95616

Project: lone
Project Number: [none]
Project Manager: Joel Kiff

CLS Work Order #: CMJ1093
COC #: 35548

CAM 17 Metals

Analyte	Result	Reporting Limit	Units	Dilution	Batch	Prepared	Analyzed	Method	Notes
Cistern (CMJ1093-02) Water Sampled: 10/29/03 15:10 Received: 10/29/03 18:40									
Mercury (H2)	ND	0.20	µg/L	1	CK30323	11/03/03	11/04/03	EPA 7470	
Bawter (Yellow Pump) (CMJ1093-03) Water Sampled: 10/29/03 16:15 Received: 10/29/03 18:40									
Arsenic	ND	5.0	µg/L	1	CJ33117	10/31/03	11/10/03	EPA 6020	
Lead	ND	5.0	"	"	"	"	"	"	
Selenium	ND	5.0	"	"	"	"	"	"	
Thallium	ND	10	"	"	"	"	"	"	
Antimony	ND	50	"	"	CJ33119	10/31/03	11/01/03	EPA 6010B	
Barium	120	20	"	"	"	"	"	"	
Beryllium	ND	5.0	"	"	"	"	"	"	
Cadmium	ND	10	"	"	"	"	"	"	
Cobalt	ND	20	"	"	"	"	"	"	
Chromium	ND	20	"	"	"	"	"	"	
Copper	27	20	"	"	"	"	"	"	
Molybdenum	ND	20	"	"	"	"	"	"	
Nickel	ND	20	"	"	"	"	"	"	
Silver	ND	10	"	"	"	"	"	"	
Vanadium	ND	20	"	"	"	"	"	"	
Zinc	ND	20	"	"	"	"	"	"	
Mercury (H1)	ND	0.20	"	"	CK30323	11/03/03	11/04/03	EPA 7470	
Bawter (Red Pump House) (CMJ1093-04) Water Sampled: 10/29/03 16:35 Received: 10/29/03 18:40									
Arsenic	ND	5.0	µg/L	1	CJ33117	10/31/03	11/10/03	EPA 6020	
Lead	ND	5.0	"	"	"	"	"	"	
Selenium	ND	5.0	"	"	"	"	"	"	
Thallium	ND	10	"	"	"	"	"	"	
Antimony	ND	50	"	"	CJ33119	10/31/03	11/01/03	EPA 6010B	
Barium	39	20	"	"	"	"	"	"	
Beryllium	ND	5.0	"	"	"	"	"	"	
Cadmium	ND	10	"	"	"	"	"	"	
Cobalt	ND	20	"	"	"	"	"	"	
Chromium	ND	20	"	"	"	"	"	"	
Copper	ND	20	"	"	"	"	"	"	
Molybdenum	ND	20	"	"	"	"	"	"	
Nickel	ND	20	"	"	"	"	"	"	

CA DOHS ELAP Accreditation/Registration Number 1233

CALIFORNIA LABORATORY SERVICES

11/12/03 15:35

KIFF Analytical
2795 Second St. Suite 300; Suite D
Davis, CA 95616

Project: Ione
Project Number: [none]
Project Manager: Joel Kiff

CLS Work Order #: CMJ1093
COC #: 35548

CAM 17 Metals

Analyte	Result	Reporting Limit	Units	Dilution	Batch	Prepared	Analyzed	Method	Notes
Haueter (Red Pump House) (CMJ1093-04) Water Sampled: 10/29/03 16:35 Received: 10/29/03 18:40									
Silver	ND	10	µg/L	1	CJ33119	10/31/03	11/01/03	EPA 6010B	
Vanadium	ND	20	"	"	"	"	"	"	
Zinc	ND	20	"	"	"	"	"	"	
Mercury	ND	0.20	"	"	CK30323	11/03/03	11/04/03	EPA 7470	

CA DOHS ELAP Accreditation/Registration Number 1233

CALIFORNIA LABORATORY SERVICES

11/12/03 15:35

KIFF Analytical
2795 Second St. Suite 300; Suite D
Davis, CA 95616

Project: Ione
Project Number: [none]
Project Manager: Joel Kiff

CLS Work Order #: CMJ1093
COC #: 35548

Conventional Chemistry Parameters by APHA/EPA Methods

Analyte	Result	Reporting		Dilution	Batch	Prepared	Analyzed	Method	Notes
		Limit	Units						
Matulich (CMJ1093-01) Water Sampled: 10/29/03 14:05 Received: 10/29/03 18:40									
Total Alkalinity	180	5.0	mg/L	1	CJ33040	10/30/03	10/30/03	EPA 310.1	
Bicarbonate as CaCO3	180	5.0	"	"	"	"	"	"	
Carbonate as CaCO3	ND	5.0	"	"	"	"	"	"	
Hydroxide as CaCO3	ND	5.0	"	"	"	"	"	"	
Chloride	7.0	0.50	"	"	CJ33026	10/30/03	10/30/03	EPA 300.0	
Fluoride	0.34	0.10	"	"	"	"	"	"	
Nitrate as NO3	ND	2.0	"	"	"	"	"	"	
Sulfate as SO4	2.2	0.50	"	"	"	"	"	"	
Specific Conductance (EC)	340	1.0	µmhos/cm	"	CJ33038	10/30/03	10/30/03	EPA 120.1	
Methylene Blue Active Substances	ND	0.10	mg/L	"	CJ33020	10/30/03	10/30/03	EPA 425.1	
Calcium	32	1.0	"	"	CK30404	11/04/03	11/04/03	200.7/2340B	
Magnesium	18	1.0	"	"	"	"	"	"	
Potassium	3.4	1.0	"	"	"	"	"	"	
Sodium	23	1.0	"	"	"	"	"	"	
Hardness as CaCO3	160	1.0	"	"	"	"	"	"	
pH	8.00		pH Units	"	CJ33015	10/30/03	10/30/03	EPA 150.1	
Total Dissolved Solids	200	10	mg/L	"	CK30326	11/03/03	11/03/03	EPA 160.1	
Cistern (CMJ1093-02) Water Sampled: 10/29/03 15:10 Received: 10/29/03 18:40									
Total Alkalinity	180	5.0	mg/L	1	CJ33040	10/30/03	10/30/03	EPA 310.1	
Bicarbonate as CaCO3	180	5.0	"	"	"	"	"	"	
Carbonate as CaCO3	ND	5.0	"	"	"	"	"	"	
Hydroxide as CaCO3	ND	5.0	"	"	"	"	"	"	
Chloride	8.9	0.50	"	"	CJ33026	10/30/03	10/30/03	EPA 300.0	
Fluoride	0.36	0.10	"	"	"	"	"	"	
Nitrate as NO3	ND	2.0	"	"	"	"	"	"	
Sulfate as SO4	29	0.50	"	"	"	"	"	"	
Specific Conductance (EC)	390	1.0	µmhos/cm	"	CJ33038	10/30/03	10/30/03	EPA 120.1	
Methylene Blue Active Substances	ND	0.10	mg/L	"	CJ33020	10/30/03	10/30/03	EPA 425.1	
Calcium	44	1.0	"	"	CK30404	11/04/03	11/04/03	200.7/2340B	
Magnesium	23	1.0	"	"	"	"	"	"	
Potassium	ND	1.0	"	"	"	"	"	"	
Sodium	15	1.0	"	"	"	"	"	"	
Hardness as CaCO3	210	1.0	"	"	"	"	"	"	
pH	7.40		pH Units	"	CJ33015	10/30/03	10/30/03	EPA 150.1	

CA DOHS ELAP Accreditation/Registration Number 1233

CALIFORNIA LABORATORY SERVICES

11/12/03 15:35

KIFF Analytical
2795 Second St. Suite 300; Suite D
Davis, CA 95616

Project: Ione
Project Number: [none]
Project Manager: Joel Kiff

CLS Work Order #: CMJ1093
COC #: 35548

Conventional Chemistry Parameters by APHA/EPA Methods

Analyte	Result	Reporting Limit	Units	Dilution	Batch	Prepared	Analyzed	Method	Notes
Cistern (CMJ1093-02) Water Sampled: 10/29/03 15:10 Received: 10/29/03 18:40									
Total Dissolved Solids	240	10	mg/L	1	CK30326	11/03/03	11/03/03	EPA 160.1	
Haueter (Yellow Pump) (CMJ1093-03) Water Sampled: 10/29/03 16:15 Received: 10/29/03 18:40									
Total Alkalinity	340	5.0	mg/L	1	CJ33040	10/30/03	10/30/03	EPA 310.1	
Bicarbonate as CaCO3	340	5.0	"	"	"	"	"	"	
Carbonate as CaCO3	ND	5.0	"	"	"	"	"	"	
Hydroxide as CaCO3	ND	5.0	"	"	"	"	"	"	
Chloride	25	0.50	"	"	CJ33026	10/30/03	10/30/03	EPA 300.0	
Fluoride	0.17	0.10	"	"	"	"	"	"	
Nitrate as NO3	ND	2.0	"	"	"	"	"	"	
Sulfate as SO4	250	10	"	20	"	"	"	"	
Specific Conductance (EC)	1000	1.0	µmhos/cm	1	CJ33038	10/30/03	10/30/03	EPA 120.1	
Methylene Blue Active Substances	ND	0.10	mg/L	"	CJ33020	10/30/03	10/30/03	EPA 425.1	
Calcium	160	1.0	"	"	CK30404	11/04/03	11/04/03	200.7/2340B	
Magnesium	53	1.0	"	"	"	"	"	"	
Potassium	2.6	1.0	"	"	"	"	"	"	
Sodium	26	1.0	"	"	"	"	"	"	
Hardness as CaCO3	610	1.0	"	"	"	"	"	"	
pH	7.12		pH Units	"	CJ33015	10/30/03	10/30/03	EPA 150.1	
Total Dissolved Solids	760	10	mg/L	"	CK30326	11/03/03	11/03/03	EPA 160.1	
Haueter (Red Pump House) (CMJ1093-04) Water Sampled: 10/29/03 16:35 Received: 10/29/03 18:40									
Total Alkalinity	630	5.0	mg/L	1	CJ33040	10/30/03	10/30/03	EPA 310.1	
Bicarbonate as CaCO3	630	5.0	"	"	"	"	"	"	
Carbonate as CaCO3	ND	5.0	"	"	"	"	"	"	
Hydroxide as CaCO3	ND	5.0	"	"	"	"	"	"	
Chloride	26	0.50	"	"	CJ33026	10/30/03	10/30/03	EPA 300.0	
Fluoride	0.24	0.10	"	"	"	"	"	"	
Nitrate as NO3	ND	2.0	"	"	"	"	"	"	
Sulfate as SO4	230	10	"	20	"	"	"	"	
Specific Conductance (EC)	1400	1.0	µmhos/cm	1	CJ33038	10/30/03	10/30/03	EPA 120.1	
Methylene Blue Active Substances	ND	0.10	mg/L	"	CJ33020	10/30/03	10/30/03	EPA 425.1	
Calcium	170	1.0	"	"	CK30404	11/04/03	11/04/03	200.7/2340B	
Magnesium	110	1.0	"	"	"	"	11/04/03	"	
Potassium	1.5	1.0	"	"	"	"	"	"	

CA DOHS ELAP Accreditation/Registration Number 1233

CALIFORNIA LABORATORY SERVICES

11/12/03 15:35

KIFF Analytical
2795 Second St. Suite 300; Suite D
Davis, CA 95616

Project: Ione
Project Number: [none]
Project Manager: Joel Kiff

CLS Work Order #: CMJ1093
COC #: 35548

Conventional Chemistry Parameters by APHA/EPA Methods

Analyte	Result	Reporting Limit	Units	Dilution	Batch	Prepared	Analyzed	Method	Notes
Bauer (Red Pump House) (CMJ1093-04) Water Sampled: 10/29/03 16:35 Received: 10/29/03 18:40									
Sodium	30	1.0	mg/L	1	CK30404	11/04/03	11/04/03	200.7/2340B	
Hardness as CaCO ₃	860	1.0	"	"	"	"	"	"	
pH	7.20		pH Units	"	CJ33015	10/30/03	10/30/03	EPA 150.1	
Total Dissolved Solids	910	10	mg/L	"	CK30326	11/03/03	11/03/03	EPA 160.1	

CA DOHS ELAP Accreditation/Registration Number 1233

CALIFORNIA LABORATORY SERVICES

11/12/03 15:35

KIFF Analytical
2795 Second St. Suite 300; Suite D
Davis, CA 95616

Project: Ione
Project Number: [none]
Project Manager: Joel Kiff

CLS Work Order #: CMJ1093
COC #: 35548

Microbiological Parameters by APHA Standard Methods

Analyte	Result	Reporting Limit	Units	Dilution	Batch	Prepared	Analyzed	Method	Notes
Matulich (CMJ1093-01) Water Sampled: 10/29/03 14:05 Received: 10/29/03 18:40									
Total Coliforms	Absent		N/A	1	CJ33103	10/30/03	10/31/03	SM 9223	
E. Coli	Absent		"	"	"	"	"	"	
Cistern (CMJ1093-02) Water Sampled: 10/29/03 15:10 Received: 10/29/03 18:40									
Total Coliforms	Present		N/A	1	CJ33103	10/30/03	10/31/03	SM 9223	
E. Coli	Present		"	"	"	"	"	"	
Haueter (Yellow Pump) (CMJ1093-03) Water Sampled: 10/29/03 16:15 Received: 10/29/03 18:40									
Total Coliforms	Present		N/A	1	CJ33103	10/30/03	10/31/03	SM 9223	
E. Coli	Absent		"	"	"	"	"	"	
Haueter (Red Pump House) (CMJ1093-04) Water Sampled: 10/29/03 16:35 Received: 10/29/03 18:40									
Total Coliforms	Absent		N/A	1	CJ33103	10/30/03	10/31/03	SM 9223	
E. Coli	Absent		"	"	"	"	"	"	

CA DOHS ELAP Accreditation/Registration Number 1233

CALIFORNIA LABORATORY SERVICES

11/12/03 15:35

KIFF Analytical
2795 Second St. Suite 300; Suite D
Davis, CA 95616

Project: Ione
Project Number: [none]
Project Manager: Joel Kiff

CLS Work Order #: CMJ1093
COC #: 35548

Notes and Definitions

BT-01 Present

BT-02 Absent

QM-07 The spike recovery was outside acceptance limits for the MS and/or MSD. The batch was accepted based on acceptable LCS/LCSD recovery.

QM-08 The spike recovery was outside acceptance limits for the LCS or LCSD. The batch was accepted based on acceptable MS/MSD recoveries & RPD's.

QM-4X The spike recovery was outside of QC acceptance limits for the MS and/or MSD due to analyte concentration at 4 times or greater the spike concentration. The QC batch was accepted based on LCS and/or LCSD recoveries within the acceptance limits.

DET Analyte DETECTED

ND Analyte NOT DETECTED at or above the reporting limit

NR Not Reported

dry Sample results reported on a dry weight basis

RPD Relative Percent Difference

Forms/coc 121001.019

Calscience
Environmental
Laboratories, Inc.

December 24, 2003

Joel Kiff
Kiff Analytical
2795 2nd Street, Suite 300
Davis, CA 95616-6593

Subject: **Calscience Work Order No.:** 03-12-1153
Client Reference: lone

Dear Client:

Enclosed is an analytical report for the above-referenced project. The samples included in this report were received 12/18/03 and analyzed in accordance with the attached chain-of-custody.

Unless otherwise noted, all analytical testing was accomplished in accordance with the guidelines established in our Quality Assurance Program Manual, applicable standard operating procedures, and other related documentation. The original report of any subcontracted analysis is provided herein, and follows the standard Calscience data package. The results in this analytical report are limited to the samples tested and any reproduction thereof must be made in its entirety.

If you have any questions regarding this report, please do not hesitate to contact the undersigned.

Sincerely,

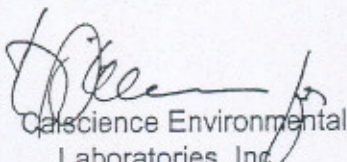
Calscience Environmental
Laboratories, Inc.
Stephen Nowak
Project Manager

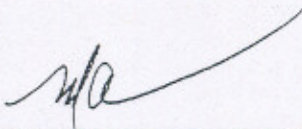

Michael J. Crisostomo
Quality Assurance Manager

Kiff Analytical
 2795 2nd Street, Suite 300
 Davis, CA 95616-6593

Date Received: 12/18/03
 Work Order No: 03-12-1153
 Preparation: N/A
 Method: EPA 376.2

Project: Ione

Page 1 of 1

Client Sample Number	Lab Sample Number	Date Collected	Matrix	Date Prepared	Date Analyzed	QC Batch ID
Matulich end	03-12-1153-1	12/16/03	Aqueous	N/A	12/22/03	31222SB2

Parameter	Result	RL	DF	Qual	Units
Sulfide, Total	ND	0.050	1		mg/L

Client Sample Number	Lab Sample Number	Date Collected	Matrix	Date Prepared	Date Analyzed	QC Batch ID
Method Blank	099-05-089-1505	N/A	Aqueous	N/A	12/22/03	31222SB2

Parameter	Result	RL	DF	Qual	Units
Sulfide, Total	ND	0.050	1		mg/L

RL - Reporting Limit DF - Dilution Factor Qual - Qualifiers

7440 Lincoln Way, Garden Grove, CA 92841-1427 • TEL: (714) 895-5494 • FAX: (714) 894-7501

Quality Control - Duplicate

Kiff Analytical
 2795 2nd Street, Suite 300
 Davis, CA 95616-6593

Date Received: 12/18/03
 Work Order No: 03-12-1153
 Preparation: N/A
 Method: EPA 376.2

Project: lone

Quality Control Sample ID	Matrix	Instrument	Date Prepared:	Date Analyzed:	Duplicate Batch Number
Matulich end	Aqueous	N/A	N/A	12/22/03	31222SD2

Parameter	Sample Conc	DUP Conc	RPD	RPD Cl	Qualifiers
Sulfide, Total	ND	ND	NA	0-25	

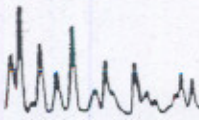

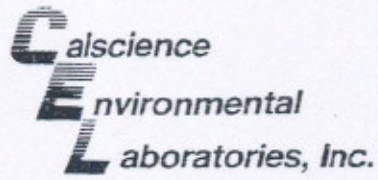

Glossary of Terms and Qualifiers

Work Order Number: 03-12-1153

<u>Qualifier</u>	<u>Definition</u>
ND	Not detected at indicated reporting limit.

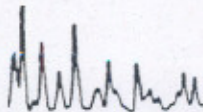

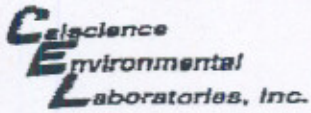

WORK ORDER #: 03 - 12 - 1153

Cooler 1 of 1

SAMPLE RECEIPT FORM

CLIENT: KIFF

DATE: 12-18-03

TEMPERATURE - SAMPLES RECEIVED BY:

CALSCIENCE COURIER:

- Chilled, cooler with temperature blank provided.
- Chilled, cooler without temperature blank.
- Chilled and placed in cooler with wet ice.
- Ambient and placed in cooler with wet ice.
- Ambient temperature.
- °C Temperature blank.

LABORATORY (Other than CalScience Courier):

- 4 °C Temperature blank.
- °C IR thermometer.
- Ambient temperature.

Initial: WB

CUSTODY SEAL INTACT:

Sample(s): _____ Cooler: No (Not Intact): _____ Not Applicable (N/A): _____

Initial: WB

SAMPLE CONDITION:

	Yes	No	N/A
Chain-Of-Custody document(s) received with samples.....	<input checked="" type="checkbox"/>	<input type="checkbox"/>	<input type="checkbox"/>
Sample container label(s) consistent with custody papers.....	<input checked="" type="checkbox"/>	<input type="checkbox"/>	<input type="checkbox"/>
Sample container(s) intact and good condition.....	<input checked="" type="checkbox"/>	<input type="checkbox"/>	<input type="checkbox"/>
Correct containers for analyses requested.....	<input checked="" type="checkbox"/>	<input type="checkbox"/>	<input type="checkbox"/>
Proper preservation noted on sample label(s).....	<input checked="" type="checkbox"/>	<input type="checkbox"/>	<input type="checkbox"/>
VOA vial(s) free of headspace.....	<input type="checkbox"/>	<input type="checkbox"/>	<input checked="" type="checkbox"/>
Tedlar bag(s) free of condensation.....	<input type="checkbox"/>	<input type="checkbox"/>	<input checked="" type="checkbox"/>

Initial: WB

COMMENTS:

Calscience
Environmental
Laboratories, Inc.

December 16, 2003

Joel Kiff
Kiff Analytical
2795 2nd Street, Suite 300
Davis, CA 95616-6593

Subject: **Calscience Work Order No.:** 03-12-0596
Client Reference: lone

Dear Client:

Enclosed is an analytical report for the above-referenced project. The samples included in this report were received 12/10/2003 and analyzed in accordance with the attached chain-of-custody.

Unless otherwise noted, all analytical testing was accomplished in accordance with the guidelines established in our Quality Assurance Program Manual, applicable standard operating procedures, and other related documentation. The original report of any subcontracted analysis is provided herein, and follows the standard Calscience data package. The results in this analytical report are limited to the samples tested and any reproduction thereof must be made in its entirety.

If you have any questions regarding this report, please do not hesitate to contact the undersigned.

Sincerely,

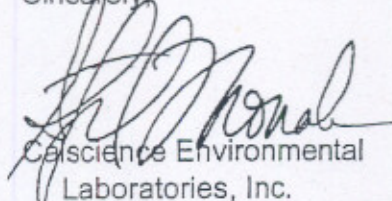
Calscience Environmental
Laboratories, Inc.
Stephen Nowak
Project Manager

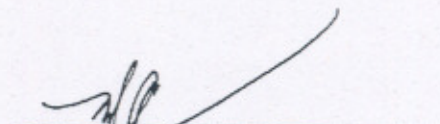

Michael J. Crisostomo
Quality Assurance Manager

Analytical Report

Kiff Analytical
 2795 2nd Street, Suite 300
 Davis, CA 95616-6593

Date Received: 12/10/03
 Work Order No: 03-12-0596
 Preparation: N/A
 Method: EPA 376.2

Project: lone

Page 1 of 1

Client Sample Number	Lab Sample Number	Date Collected	Matrix	Date Prepared	Date Analyzed	QC Batch ID
Haueter Red 2	03-12-0596-1	12/08/03	Aqueous	N/A	12/12/03	31212SB1

Parameter	Result	RL	DF	Qual	Units
Sulfide, Total	33	0.50	10	D	mg/L

Method Blank	099-05-089-1,498	N/A	Aqueous	N/A	12/12/03	31212SB1
--------------	------------------	-----	---------	-----	----------	----------

Parameter	Result	RL	DF	Qual	Units
Sulfide, Total	ND	0.050	1		mg/L

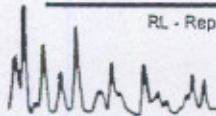

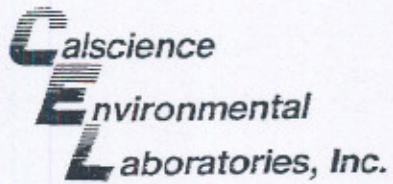

Quality Control - Duplicate

Kiff Analytical
2795 2nd Street, Suite 300
Davis, CA 95616-6593

Date Received: 12/10/03
Work Order No: 03-12-0596
Preparation: N/A
Method: EPA 376.2

Project: Ione

Quality Control Sample ID	Matrix	Instrument	Date Prepared:	Date Analyzed:	Duplicate Batch Number
03-12-0758-1	Aqueous	N/A	N/A	12/12/03	31212SD1

<u>Parameter</u>	<u>Sample Conc.</u>	<u>DUP Conc</u>	<u>RPD</u>	<u>RPD CL</u>	<u>Qualifiers</u>
Sulfide, Total	ND	ND	NA	0-25	

Work Order Number: 03-12-0596

<u>Qualifier</u>	<u>Definition</u>
D	The sample data was reported from a diluted analysis.
ND	Not detected at indicated reporting limit.

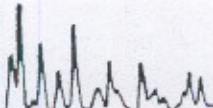

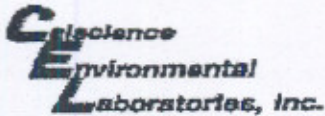

WORK ORDER #: 03 - 12 - 0596

Cooler 1 of 1

SAMPLE RECEIPT FORM

CLIENT: Kiff Analytical

DATE: 12-10-03

TEMPERATURE - SAMPLES RECEIVED BY:

CALSCIENCE COURIER:

- Chilled, cooler with temperature blank provided.
Chilled, cooler without temperature blank.
Chilled and placed in cooler with wet ice.
Ambient and placed in cooler with wet ice.
Ambient temperature.
C Temperature blank.

LABORATORY (Other than Calscience Courier):

- 7 C Temperature blank.
C IR thermometer.
Ambient temperature.

Initial: ms

CUSTODY SEAL INTACT:

Sample(s): Cooler: [checked] No (Not Intact): Not Applicable (N/A):

Initial: ms

SAMPLE CONDITION:

Table with 4 columns: Item, Yes, No, N/A. Rows include Chain-Of-Custody document(s), Sample container label(s), Sample container(s) intact, Correct containers for analyses, Proper preservation, VOA vial(s) free of headspace, and Tedlar bag(s) free of condensation.

Initial: ms

COMMENTS:

Multiple horizontal lines for handwritten comments.



2795 Second Street, Suite 300
 Davis, CA 95616
 Lab: 530.297.4800
 Fax: 530.297.4808

Cal Science Environmental
 7440 Lincoln Way
 Garden Grove, CA 92841
 714-895-5494

0596

Lab No. _____ Page 1 of 1

Project Contact (Hardcopy or PDF to): **Joel Kiff** Geotracker COELT EDD REPORT? YES NO **Chain-of-Custody Record and Analysis Request**

Company/Address: **Kiff Analytical, LLC** Sampling Company Log Code: _____

Phone No.: _____ FAX No.: _____ Global ID: _____

Project Number: _____ P.O. No.: **36170** EDF Deliverable to (Email Address): _____

Project Name: **lone** E-mail address: **inbox@kiffanalytical.com**

Project Address: _____ Sampling _____ Container _____ Preservative _____ Matrix _____

Sample Designation	Sampling		Container				Preservative					Matrix			SULFIDE	December 16, 2003	For Lab Use Only
	Date	Time	Glass Jar	Poly	Amber	Sleeve	ZnAC2	NaOH	ICE	NONE	H2SO4	WATER	SOIL				
Haueter Red 2	12/8/03	1115		1			1	1	X				X		X		

Relinquished by: Osama Albalawi / Kiff Analytical	Date: 12/9/03	Time: 1630	Received by: _____	Remarks: _____
Relinquished by: _____	Date: _____	Time: _____	Received by: _____	
Relinquished by: _____	Date: 12/11/03	Time: 9:48	Received by: Valerie Staley	
Bill to: _____				

Appendix D

Results of Soil Profile and Mantle Tests, AEG, March 2, 2004

**RESULTS OF SOIL MANTLE
AND
PERCOLATION TESTS**

PROPERTY:

IONE RANCHERIA
PLYMOUTH, AMADOR COUNTY, CALIFORNIA

PREPARED FOR:

JOE BROADHEAD
ANALYTICAL ENVIRONMENTAL SERVICES
2021 N STREET, SUITE 200
SACRAMENTO, CALIFORNIA 95814

PREPARED BY:

APPLIED ENGINEERING AND GEOLOGY, INC.
POST OFFICE BOX 247 • 578 E STREET
LINCOLN, CALIFORNIA 95648
OFFICE 916.645.6014 • FAX 916.645.6098 • EMAIL aeg@psyber.com

MARCH 2, 2004

TABLE OF CONTENTS

1.0	INTRODUCTION	1
2.0	GENERAL SITE INFORMATION	1
3.0	MANTLE AND PERCOLATION TESTS	4
3.1	Mantle Tests	4
3.2	Percolation Tests	8
3.3	Trench Percolation Tests	11
3.4	Backfilling of Trenches	12
3.5	Spring Investigation	12
4.0	DISCUSSION, CONCLUSIONS, AND RECOMMENDATIONS	12
4.1	Discussion	12
4.2	Conclusions	15
4.3	Recommendations	17
5.0	STATEMENT OF LIABILITY	17

LIST OF TABLES

3-1	Condensed Trench Logs and Measured Percolation Rates	5
3-2	Percolation Test Results	10

LIST OF FIGURES

1	Site Vicinity Map	2
2	Generalized Site Map	3
3	Location of Springs	13
4	Subsurface Disposal	16
A1-A15	Profiles of Test Pits TP1-TP35	Appendix A

LIST OF APPENDICES

Appendix A	Profiles and Cross Sections of Test Pits
Appendix B	Percolation Hole Data
Appendix C	Trench Percolation Test Results
Appendix D	Spring Locations and Descriptions

1.0 INTRODUCTION

At the request of Analytical Environmental Services (AES), Applied Engineering and Geology, Inc. (AEG) has prepared this *Results of Soil Mantle and Percolation Tests* (Report) to document investigative activities for defining near surface geologic and hydrologic conditions present at the Ione Rancheria (Project). The activities performed at the Project included:

- 45 Soil Mantle Tests;
- 19 Percolation Tests;
- Four Trench Percolation Tests;
- GPS Survey of all Trench and Well Locations; and,
- Filling in of Trenches.

2.0 GENERAL SITE INFORMATION

The Project is located on the east side of Highway 49 at the southern edge of the City of Plymouth, Amador County, California (see **Figure 1**). A general layout of the Project and the locations of trenches and percolation holes are shown on **Figure 2**.

The Project is on the western side of the New Melones Fault Zone and is approximately 2.5 miles east of the Bear Mountain Fault Zone. The onsite geologic materials consist of Upper Jurassic marine sedimentary and metasedimentary rocks of the Mariposa Formation with greenstone along the western edge. These sedimentary and metasedimentary rocks are primarily weathered shale and slate with minor thin beds of sandstone. The soil layer is thin over most of the Site, ranging from less than three inches to a maximum of approximately two feet, with the exception of one or two locations where it is thicker.

No ground water was encountered by any of the excavation activities, but there is one spring in a drainage within the southwest quadrant and others in deep drainage courses east of the Project. A spring is also thought to supply water to the pond in the southwest corner of the Project.

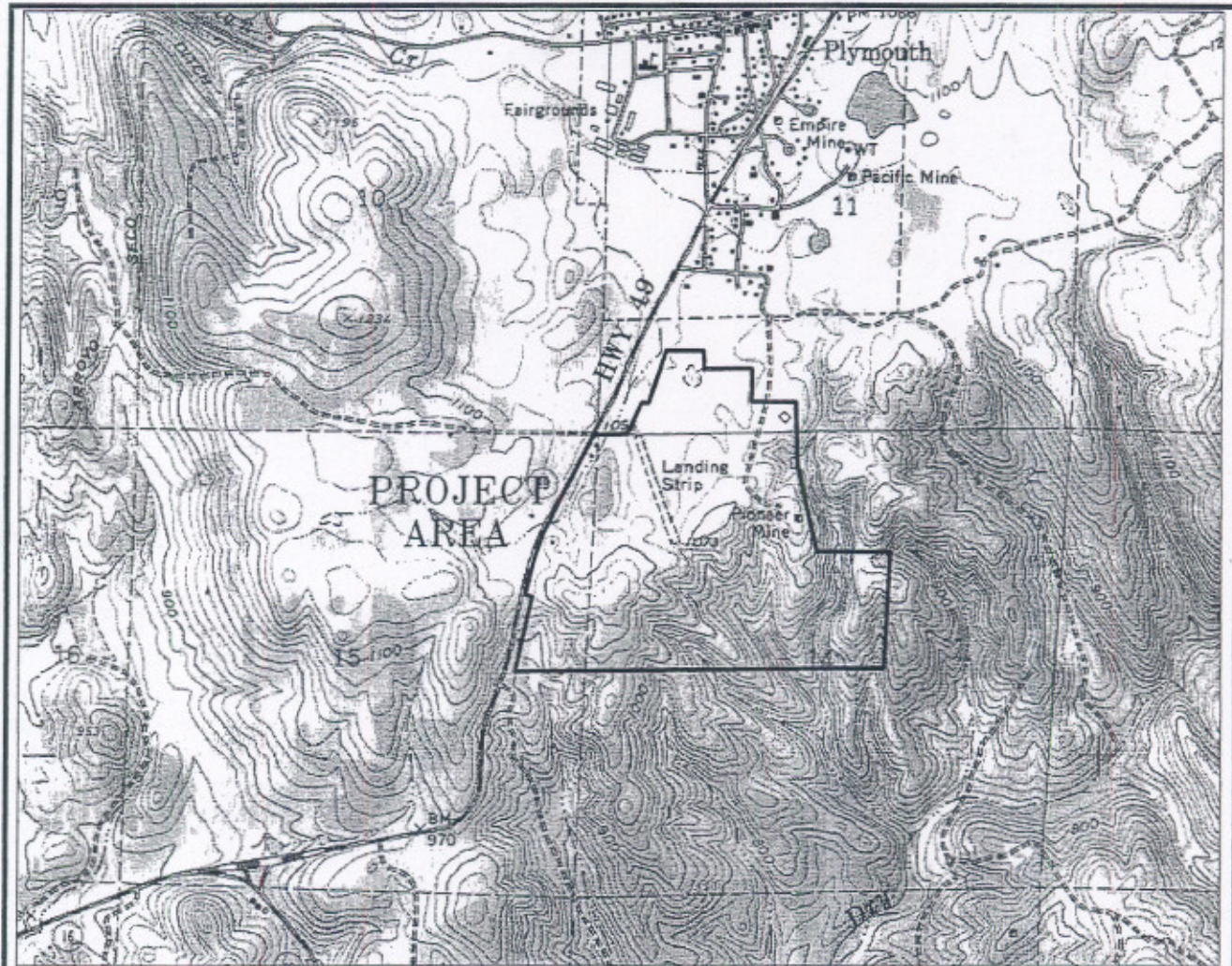

TN* / MN
15°

0 5 1 MILE
0 1000 FEET 0 500 1000 METERS

Printed from TOPO! ©2000 National Geographic Holdings (www.topo.com)

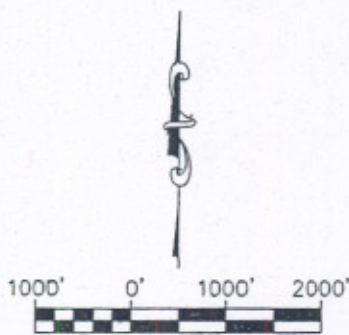

SCALE 1"=2000' +/-
JULY 6, 1999

S:\AEG DOCUMENTS\IONE\IONE FIG. 1.DWG(22)

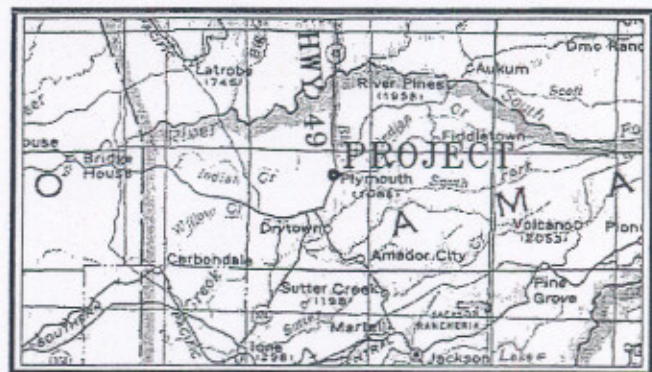

NOT TO SCALE

A PPLIED
E NGINEERING AND
G EOLOGY, INC.

P.O. BOX 247, LINCOLN, CA 95648
(916) 645-6014 (916) 645-6098 FAX

SITE VICINITY MAP
IONE RANCHERIA
PLYMOUTH, AMADOR COUNTY, CALIFORNIA

FIGURE 1

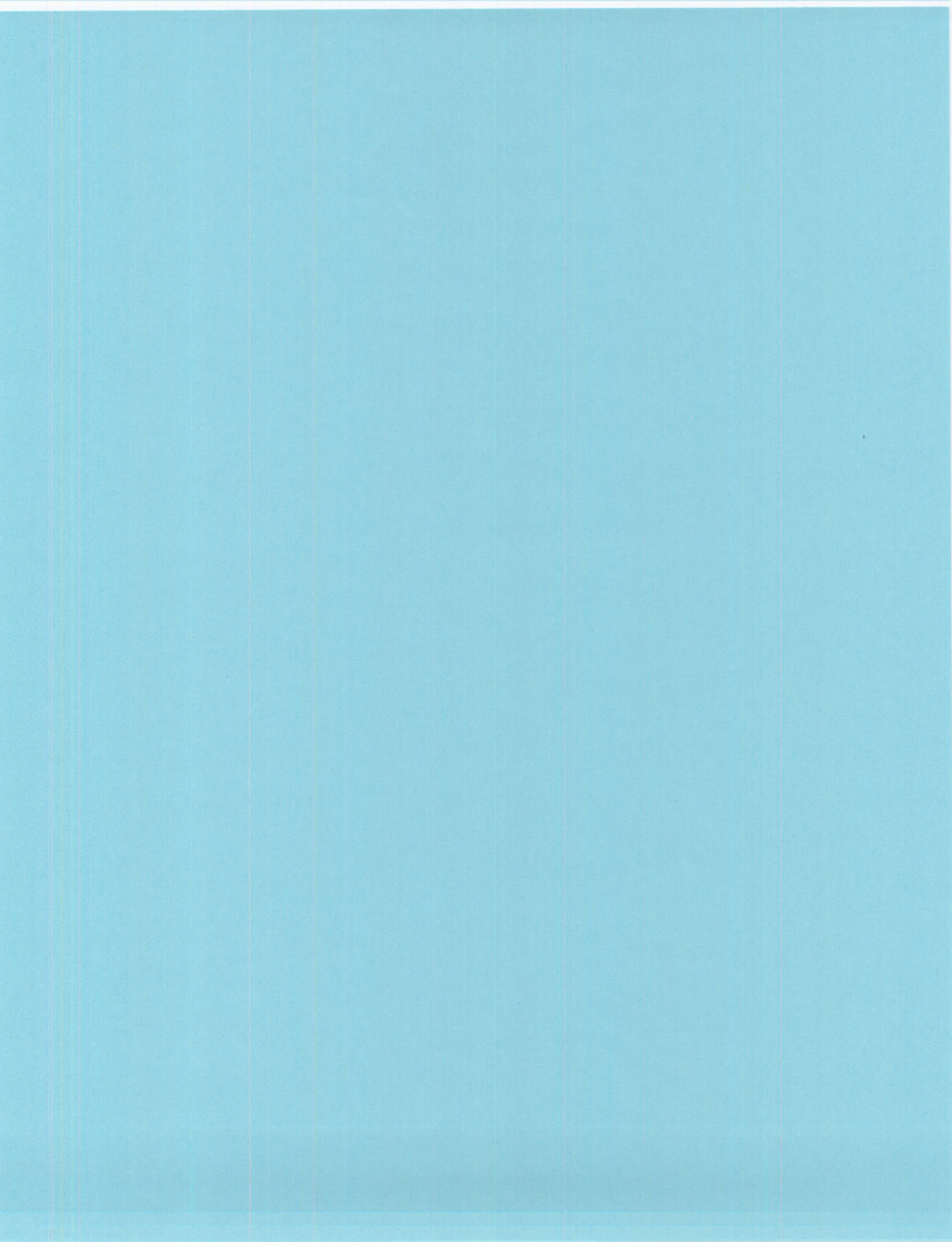

3.0 MANTLE AND PERCOLATION TESTS

Mantle and percolation tests were performed in an attempt to determine vertical and horizontal movement of water within the subsurface at the Project.

3.1 Mantle Tests

The trenches were placed at locations chosen by Mike Ducker of HydroScience Engineers (HSe) and Elgar Stephens of AEG. The 45 trench locations are shown on **Figure 2**. The trenches were dug with two different size excavators operated by Price Construction and Environmental. The deep trenches were approximately 18 feet long, with a sloping base. Shallow trenches were approximately three feet deep with a flat base. Percolation holes were dug by AEG personnel at locations within or beside each trench that would allow the percolation testing to be conducted at specified depths below ground surface (bgs). Trench descriptions are included in **Appendix A**.

A total of 45 trenches were excavated to investigate soil conditions over the areas being considered for the discharge of treated water. The first few trenches were excavated using a Takeuchi 6,000 lb excavator. It soon became evident that this machine was not capable of excavating into the rocky conditions that were encountered. A John Deere 120C was then brought onsite and used for the remaining trench excavations.

Of the 45 backhoe trenches placed at the Project, only trenches TP-1 through TP-35 were logged. Trenches TP-36 through TP-45 were found to contain only a thin layer of soil, and due to time constraints were not fully logged. The logging included a description of the material, the color of the material as determined by Munsell charts, and measurements of the dip and strike of the beds where they could be determined. Trench Logs, including descriptions of the materials, are in **Appendix A**. The dips and strikes of outcrops across the Project and in cut slopes are shown on **Figure 2**. The soil types at each of the test trenches, along with the depth at which the percolation test was conducted and the percolation rate at that depth are tabulated in **Table 3-1**.

TABLE 3-1
 Condensed Trench Logs and Measured Percolation Rates

Trench/ Percolation Hole	Condensed Material Description	Depth of Material (feet/inches)	Infiltration Rate at Indicated Depth (minutes per inch)
TP-1	Sandy CLAY loam	1' 2"	3.33 @ 11"
	Shale	7' 0"	
TP-2	Sandy CLAY loam	0' 6"	No Percolation Test Done Here
	Sandy Clay/Shale Mixture	2' 6"	
	Shale	7' 6"	
TP-3	Sandy CLAY loam	5"	No Percolation Test Done Here
	Broken Shale	1' 8"	
	Shale	2' 9"	
TP-4	Sandy CLAY loam	1' 2"	No Percolation Test Done Here
	Weathered Shale	3' 0"	
	Shale	8' 0"	
TP-5	Sandy CLAY loam	W: 1' 3" - E: 0'	No Percolation Test Done Here
	Weathered Shale	7' 6"	
TP-6	Sandy CLAY loam	0' 7"	No Percolation Test Done Here
	Weathered Shale	2' 0"	
	Shale	7' 0"	
TP-7	Sandy CLAY loam	0' 9"	No Percolation Test Done Here
	Shale	7' 0"	
TP-8	Sandy CLAY loam	1' 3"	3.03 @ 9"
	Shale	3' 0"	
TP-9	Sandy CLAY loam	2' 0"	0.83 @ 9" 2.78 @ 30"
	Fractured Shale	3' 0"	
	Shale	4' 6"	
TP-10	Sandy CLAY loam	0' 6"	No Percolation Test Done Here
	Shale	6' 0"	
TP-10A	Sandy CLAY loam	0' 3"	No Percolation Test Done Here
	Shale	3' 0"	
TP-10B	Sandy CLAY loam	0' 3"	No Percolation Test Done Here
	Weathered Shale	2' 0"	

TABLE 3-1			
Condensed Trench Logs and Measured Percolation Rates			
Trench/ Percolation Hole	Condensed Material Description	Depth of Material (feet/inches)	Infiltration Rate at Indicated Depth (minutes per inch)
TP-11	Sandy CLAY loam	0' 5"	No Percolation Test Done Here
	Weathered Shale	2' 0"	
	Shale	3' 0"	
TP-12	Sandy CLAY loam	0' 6"	No Percolation Test Done Here
	Weathered Shale	2' 0"	
	Shale	6' 0"	
TP-12A	Sandy CLAY loam	0' 3"	No Percolation Test Done Here
	Weathered Shale	3' 0"	
TP-12B	Sandy CLAY loam	0' 6"	No Percolation Test Done Here
	Weathered Shale	2' 0"	
TP-13	Sandy CLAY loam	2' 0"	No Percolation Test Done Here
	Shale	8' 6"	
TP-13A	Shale	1' 5"	No Percolation Test Done Here
	Weathered Shale	2' 6"	
TP-13B	Shale	1' 0"	No Percolation Test Done Here
	Weathered Shale	2' 0"	
TP-14	Sandy CLAY loam	0' 3"	No Percolation Test Done Here
	Weathered Shale	6' 0"	
TP-15	Sandy CLAY loam	1' 0"	No Percolation Test Done Here
	Weathered Shale	2' 6"	
	Less Weathered Shale	5' 0"	
TP-16	Sandy CLAY loam	0' 10"	16.67 @ 9" 75 @ 60"
	Weathered Shale	4' 6"	
TP-17	Sandy CLAY loam	0' 9"	0.18 @ 9" 16.67 @ 24"
	Weathered Shale	5' 0"	
TP-18	Soil	0' 3"	No Percolation Test Done Here
	Weathered Shale	6' 0"	
TP-19	Sandy CLAY loam	0' 2"	No Percolation Test Done Here
	Weathered Shale	3' 0"	

TABLE 3-1
 Condensed Trench Logs and Measured Percolation Rates

Trench/ Percolation Hole	Condensed Material Description	Depth of Material (feet/inches)	Infiltration Rate at Indicated Depth (minutes per inch)
TP-20	Soil	0' 2"	No Percolation Test Done Here
	Shale	6' 0"	
TP-21	Sandy CLAY loam	0' 9"	6.67 @ 9" moved horizontally @ 18"
	Shale	2' 0"	
TP-22	Sandy CLAY loam	0' 8"	No Percolation Test Done Here
	Shale	5' 0"	
TP-23	Sandy CLAY loam	0' 8"	No Percolation Test Done Here
	Very broken Shale	2' 0"	
	Less weathered Shale	7' 0"	
TP-24	Sandy CLAY loam	0' 6"	No Percolation Test Done Here
	Shale and Soil mixture	2' 0"	
	Shale	5' 0"	
TP-24A	Soil	0' 3"	No Percolation Test Done Here
	Shale	3' 0"	
TP-24B	Soil	0' 2"	No Percolation Test Done Here
	Shale	3' 0"	
TP-25	Sandy CLAY loam	0' 3"	No Percolation Test Done Here
	Shale	2' 4"	
TP-26	Sandy CLAY loam	3' 0"	No Percolation Test Done Here
	Shale and Soil mixture	5' 0"	
TP-27	Sandy CLAY loam	5' 0"	42.86 @ 9" & 100 @ 30"
TP-28	Sandy CLAY loam	0' 2"	No Percolation Test Done Here
	Shale	2' 8"	
TP-29	Sandy CLAY loam	0' 1.5"	No Percolation Test Done Here
	Shale	3' 2"	
TP-30	Sandy CLAY loam	0' 4"	No Percolation Test Done Here
	Sandy Clay SHALE	2' 6"	
	Shale	6' 0"	

TABLE 3-1			
Condensed Trench Logs and Measured Percolation Rates			
Trench/ Percolation Hole	Condensed Material Description	Depth of Material (feet/inches)	Infiltration Rate at Indicated Depth (minutes per inch)
PH-31S	None	0' 9"	3.00 @ 9"
PH-31D	None	1' 6"	2.33 @ 18"
TP-32	Sandy CLAY loam	0' 3"	No Percolation Test Done Here
	Weathered Shale	2' 5"	
TP-33	Sandy CLAY loam	0' 4"	2.86 @ 9"
	Weathered Shale	1' 2"	
	Shale	3' 5"	
TP-34	Sandy CLAY loam	0' 6"	6.67 @ 9"
	Shale	9' 0"	0.58 @ 18"
TP-35	Sandy CLAY loam	0' 6"	1.89 @ 9" 75 @ 18"
	CLAY loam with stone line	2' 0"	
	Weathered Feldspar	4' 0"	

3.2 Percolation Tests

All trench locations were evaluated as to the need of a percolation test. There were 45 trenches with 19 percolation test holes located within or adjacent to 11 of the trenches. It was believed that some of the trench locations exhibited soil or rock conditions that were duplicates of others, and that there was no need to place percolation holes at all of them. The very thin soil layer at many trench locations was also considered evidence that percolation testing at those locations would not provide useful data. Locations for percolation test holes were distributed over the entire area being considered for disposal of treated water. Individual percolation test holes were placed within or adjacent to the trench at a depth to test the soil layer considered most likely to be the limiting layer for downward migration of applied water. For percolation test results see **Table 3-2** and **Appendix B**.

The percolation holes have been assigned numbers that correspond to the depth and the number of the trench at which they were located. For example, in the case of Trench 16, a percolation hole on the surface near the trench has been designated TP-16S and the percolation hole within the trench has been designated TP-16D. An effort was made to dig each percolation hole to have an inside diameter of seven inches. After each test hole had been dug, approximately two inches of pea gravel were placed in the bottom, a six inch diameter sleeve constructed of 1/8-inch hardware cloth was placed in it and pea gravel was placed around the sleeve. Each was filled to a depth of approximately 12 to 14 inches with clean water on the evening of October 27, 2003 and allowed to presoak overnight.

On the morning of October 28, 2003, each hole received enough water to bring the total water level up to six inches. Water levels were checked either approximately every 30 minutes over a four hour period, or every ten minutes over a two hour period if the 30 minute intervals proved to be too long, so that the holes went dry by the time of the next measurement. However, two percolation holes had such a high infiltration rate that they went dry in less than ten minutes. Because of this, the duration of the tests at these two locations were shortened to 50 minutes (TP-9S) and to 30 minutes (TP-17S).

At those locations where the hole was repeatedly dry by the time of the next 30 minute measurement, the test was modified to start with six inches of water in the test hole and record the water level every ten minutes over the next 30 minutes. If the hole went dry in less than ten minutes, the time it took for the hole to go dry was recorded.

TABLE 3-2 Percolation Test Results					
Hole Number	Test Date	Test Depth (inches)	Duration of Test (minutes)	Drop Measured by Last Reading (minutes/inch)	Infiltration Rate (minutes per inch)
TP-1S	10/29/03	11	130	1/0.3	3.33
TP-8S	10/28/03	9	151	10/3.3	3.03
TP-9S	10/28/03	9	50	5/6.0	0.83
TP-9D	10/28/03	30	110	10/3.6	2.78
TP-16S	10/28/03	9	242	30/1.8	16.67
TP-16D	10/28/03	60	241	30/0.4	75
TP-17S	10/28/03	9	30	1.08/6.0	0.18
TP-17D	10/28/03	24	160	10/0.6	16.67
TP-21S	10/28/03	9	178	10/1.5	6.67
TP-21D	10/28/03	18	249	30/-0.3*	---
TP-27S	10/28/03	9	260	30/0.7	42.86
TP-27D	10/28/03	30	261	30/0.3	100
PH-31S	10/28/03	9	158	12/4.0	3.00
PH-31D	10/28/03	18	160	10/4.3	2.33
TP-33S	10/28/03	9	150	10/3.5	2.86
TP-34S	10/28/03	9	176	2/0.3	6.67
TP-34D	10/28/03	18	120	3.5/6.0	0.58
TP-35S	10/28/03	9	140	10/5.3	1.89
TP-35D	10/28/03	18	451	30/0.4	75

* Water added to bring the water level to six inches caused horizontal flow into fractured rock. Water level in this test hole dropped as a result of the initial horizontal flow outward, then rose as water drained back into the test hole. No infiltration rate was calculated.

The results tabulated in **Table 3-2** show the infiltration rate in minutes per inch (mpi) as determined by the last reading. As is shown in this table, three locations had an infiltration rate greater than 60 mpi; five locations had an infiltration rate between 60 mpi and 5 mpi; and ten had infiltration rates less than 5 mpi.

3.3 Trench Percolation Tests

In addition to percolation tests, four sets of trenches were excavated to determine horizontal and vertical movement of water. For these tests, two additional trenches were excavated adjacent to an existing trench that had been excavated for a mantle test. The additional trenches were excavated to depths of two and four feet near an existing trench that was approximately six feet deep. For percolation hole data see **Appendix B**. For trench percolation test results see **Appendix C**.

Trench percolation tests were conducted by adding water to the shallowest (2 foot) trench that had been pre-soaked from the previous day. Material that had caved in and collected on the bottom of the trench was cleaned out using a shovel so that the trench depth at its deepest point was two feet. This location was marked as a reference point. A bar long enough to extend across this reference point was used as the point from which to measure depth to water within the trench.

At a recorded start time, water from 55-gallon drums was poured into the test trench using 5-gallon buckets. When approximately 75% of the water had been poured out with the buckets, the drum was tipped over slowly to pour out the remaining water. With two people performing this task, the time to pour all of the water from the drums into the test trench was approximately one minute.

As much water was poured into the test trench as it could hold, or the total volume in the four 55-gallon drums, whichever came first. The trench tests were conducted adjacent to test pits TP-10, TP-12, TP-13, and TP-24. The rate the water level dropped was recorded in each trench until all of the water had infiltrated out of that trench. The two adjacent deeper trenches (4 and 6-foot) were monitored for evidence of water seepage from the shallow 2-foot trench. The rate at which the applied water infiltrated into the bottom of the 2-foot trench was calculated. These calculations indicated a rate of infiltration ranging from 3.78×10^{-3} to 3.3×10^{-4} centimeters per second (cm/sec).¹

Of the four sets of trenches, only TP-24 showed evidence of horizontal flow following the test. The 4-foot trench at the TP-24 location showed moisture at its deepest point, in an area of approximately 4 feet by 1.8 feet. All of the trenches that did not show evidence of horizontal flow are assumed to have predominantly vertical flow.

¹ 3.78×10^{-3} to 3.3×10^{-4} centimeters per second (cm/sec) = 7 to 70 gallons per day per square foot (gpd/ft²)

3.4 Backfilling of Trenches

After all of the trenches had been logged and all of the percolation and infiltration tests had been completed, all of the trenches that had been dug as part of this investigation were backfilled. This was done October 30, 2003 using the large excavator that had been used to do the digging. All trenches were filled and then compacted by driving over them with the excavator.

3.5 Spring Investigation

In early December 2003, AEG conducted a walkover inspection of the properties on and adjacent to the Project. The inspection was primarily of low areas and drainage systems where springs might be located. The initial inspection was conducted before any winter rains so the springs were easily detected. A later inspection on December 16, 2003 was after the winter rains had started, and low flow had begun to appear in several of the gullies. Spring locations are identified by number on **Figure 3**. A description of the springs is included in **Appendix D**.

On December 16, 2003, there was a flow of an estimated 8 to 10 gallons per minute (gpm) in the main north-south gully that extends along the east side of the Pioneer Mine and continues until it intersects Dry Creek. This flow was in large part being provided by leakage from the dam that Mr. Haueter constructed south of his outbuildings. Water being discharged by the pumping of the Haueter well collected behind this dam, which leaked and provided most of the flow seen in this gully. A small amount of the total flow was from Spring 3 (see **Figure 3**). This same north-south gully is shown on the USGS map sheet as being an ephemeral stream.

The gully on the south side of the long southeast trending ridge along which Trenches TP-16 through TP-22 were located is also shown as being an ephemeral stream. The head of this last gully is also the location of Spring 7 (see **Figure 3**).

On December 17, 2003, AEG visited an area on the east side of Dry Creek, crossing at a ford. Water flowing in the creek bed at that time was approximately ten inches deep and ten feet wide.

4.0 DISCUSSION, CONCLUSIONS, AND RECOMMENDATIONS

4.1 Discussion

With the exception of two locations, all trenches were dug to refusal. Soil extended to the full depth of TP-26 and TP-34 (five and nine feet, respectively). TP-26 was composed of alluvial material that had migrated downslope. TP-34 was in an area of greenstone rock adjacent to shale outcrops. The geologic structure near TP-34 is unclear, but it appears to be an unconformity of steeply dipping shale on the east side of massive greenstone.

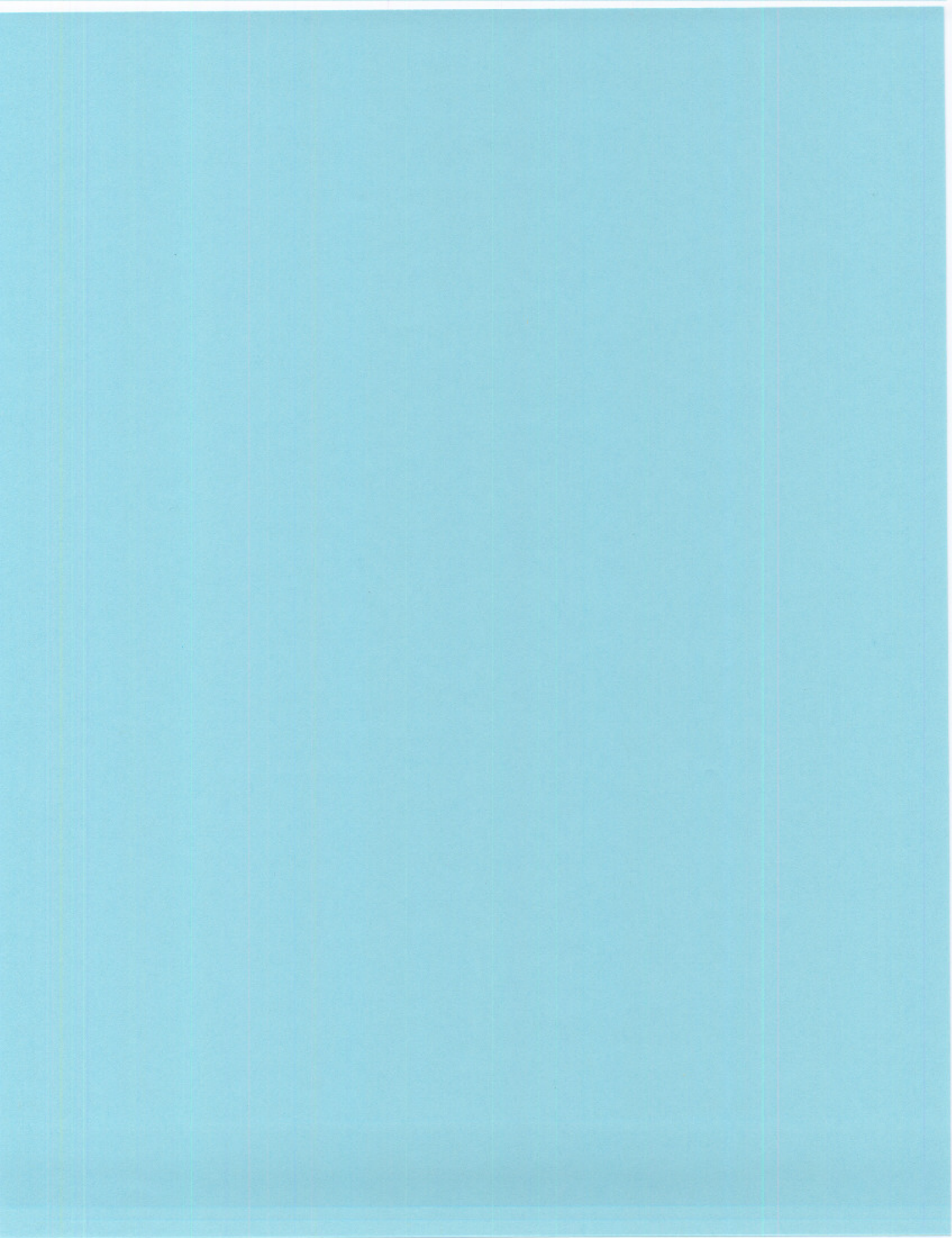

The total depths of the trenches into the shale ranged from three feet to approximately eight feet. The shale was thinly bedded and steeply dipping, with a strike that was within 20° of north. The surface soil is thin, typically less than one foot thick, with a maximum thickness of less than three feet. Most of the area is covered with grass with only a few trees. Root penetration ranged from a few inches to two feet.

The rocky nature of the subsurface material at all but two or three of the trench locations precludes using standard soil types and percolation rates to determine acceptable loading. Documents such as the EPA's Table 4.3² require that a loading rate be based on a suitable soil type. If the soil type is not suitable, under their classification, the only allowable loading rate is 0 gallons per day per square foot (gpd/ft²). With the exception of three trench locations, one on the eastern edge and the other two on the western edge of the Project, the material beneath the thin sandy clay loam is weathered rock.

Six of the 19 percolation tests had percolation rates within the desirable range of five to 60 minutes per inch (mpi). Only two of them had percolation rates slower than 60 mpi, with the slowest percolation rate being 100 mpi. The remaining ten tests had percolation rates that were under five mpi.

We believe the percolating water moved along bedding planes, but do not know whether it moved vertically or horizontally. In general, bedding planes were open to the depth of the excavated trench, and became very tight at about the depth where the excavator met refusal. The amount of water that was applied by the presoak and percolation testing could have migrated along bedding planes in either direction.

Percolation into test trenches was used at four locations in an effort to determine if percolation was in a vertical or horizontal direction. At all but one of these locations, water added to the two foot deep trench appeared to have migrated vertically, and did not appear in the adjacent four foot deep trench. The one location at which there was evidence of horizontal migration was the one where three trenches were cut across the strike of the beds. We therefore believe the horizontal movement was along bedding planes. The amount of water that appeared in the deeper trench was much less than what was added to the shallow trench, indicating there was also a component of vertical flow.

² *Suggested Hydraulic Loading and Organic Loading Rates for Sizing Infiltration Surfaces*, from the USEPA Onsite Wastewater Treatment Systems Manual.

Ground water was originally at a depth of 43 feet below ground surface (bgs) in the well at the northwest corner of the Project. After this well had been pumped extensively, the water level rose to 38 feet bgs. The elevation of the ground surface at this location is approximately 1,082 feet, placing the elevation of the water table at approximately 1,044 feet. In addition, there is one spring within the southwest corner of the area that was investigated. This spring is at an elevation of approximately 1,060 feet, and could represent either the water table at that location or a perched zone that outcrops to the surface at that location.

Springs east of the Project are at elevations of less than 1,000 feet. The areal direction of ground water flow is believed to be toward Dry Creek, which is southeast of the Project.

4.2 Conclusions

- There is only a thin layer of soil overlying bedded shale at almost all locations;
- Based on EPA's Table 4.3³, the thin layer of soil present at the Project is not a suitable material for the disposal of treated water;
- Water flows horizontally and vertically along the bedding planes of the shale;
- The high measured percolation rates were due to the percolation holes being placed within weathered, bedded shale, and are not representative of percolation rates into homogeneous soil;
- The vertical migration through unweathered rock was not measured, but is likely dependent on the presence of fractures; and,
- Soil mantle and percolation testing indicated that the area within the southwest corner of the Project would be suitable for subsurface disposal (see **Figure 4**). However, a review of this area after an extremely heavy rain indicated heavy flow to the surface. This has been interpreted to indicate very poor vertical transport into the clayey soil.

³ *Suggested Hydraulic Loading and Organic Loading Rates for Sizing Infiltration Surfaces*, from the USEPA Onsite Wastewater Treatment Systems Manual.

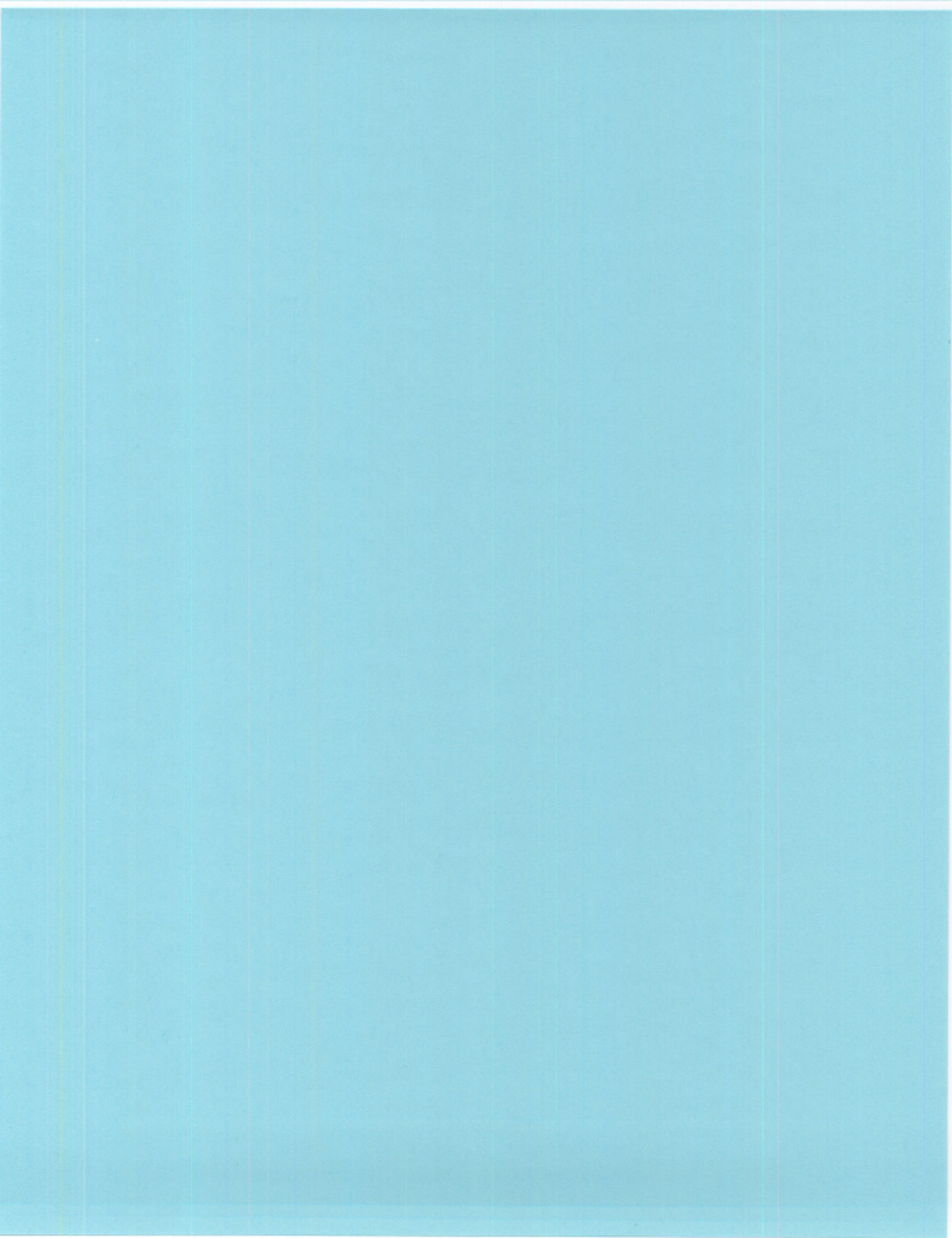

4.3 Recommendations

- Spray irrigation should be the primary method of disposal;
- Subsurface disposal of tertiary treated water should be made at low application rates (not to exceed 0.2 gpd/ft²);
- Subsurface disposal should not be done at high elevations (above 1125 feet) where the soil layer is thinner;
- **Figure 4** illustrates the areas that are acceptable for shallow subsurface and spray irrigation. The southeast trending ridge, along which trenches TP-16 through TP-22 were placed, is the most suitable location for tertiary treated water disposal, and could be used for either spray irrigation or subsurface disposal; and,
- The installation and calibration of subsurface disposal lines should be closely monitored by the responsible engineer.

5.0 STATEMENT OF LIABILITY

This *Results of Soil Mantle and Percolation Tests* (Report) was prepared by Applied Engineering and Geology, Inc. (AEG), at the request of Analytical Environmental Services (Client), using the degree of care and skill ordinarily exercised, under similar circumstances, by reputable engineers, geologists, and scientists practicing in this or similar localities in California at the time this Report was prepared. No other warranty, expressed or implied, is made as to the information and professional advice included in this Report. This Report was written to document testing activities related to the percolation rate of water at the Project based on a limited number of observation points/tests. Further investigation and testing can reduce the inherent uncertainties associated with this type of soil mantle and percolation tests. AEG's Report is based on factual information obtained from Analytical Environmental Services, and others, that has been assumed to be correct, accurate and complete. Applied Engineering and Geology, Inc., does not guarantee the correctness, accuracy, or completeness of those data.

This Report and the data within has not been prepared for use by other parties or uses other than those for which it was intended, and may not contain sufficient information for the purposes of other parties or other uses.

This Report or any part thereof may not be reproduced in any form without written permission from Applied Engineering and Geology, Inc., its Principals, or agents.

Should you have any questions regarding the content of this report, please contact the undersigned at 916.645.6014.

Sincerely,

APPLIED ENGINEERING AND GEOLOGY, INC.

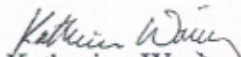
Katherine Waring
Staff Geologist

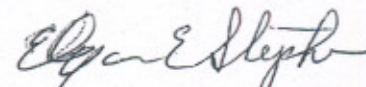

Elgar E. Stephens CEG 581
Project Geologist



Appendix A



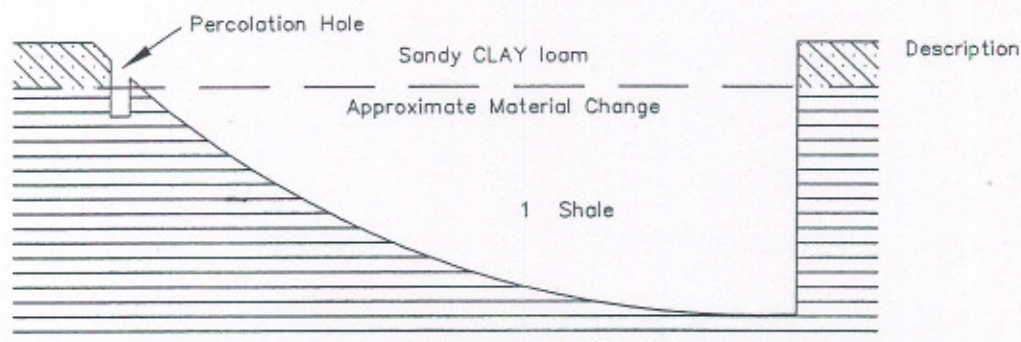





















Profiles and Cross Sections of Test Pits

BOREHOLE LOG LEGEND (TEST PIT PROFILE)



1: Notes

MATERIAL SYMBOLS

	Gravel		Top Soil / Vegetation
	Sand		Asphalt
	Fine Sand		Concrete
	Silt		Clayey SAND or Sandy CLAY
	Clay		Clayey SILT or Silty CLAY
	Silty SAND or Sandy SILT		Shale
	Sandstone		Hardpan
	Greenstone		Phyllite
	Volcanics		Limestone
	Granitic Rock		No Sample Collected Material Not Logged
	Slate		Fill Material
	Gravelly Clay		Tuff

FEET BELOW
GROUND SURFACE

TP-1
N 32° W →
SLOPE: 8°

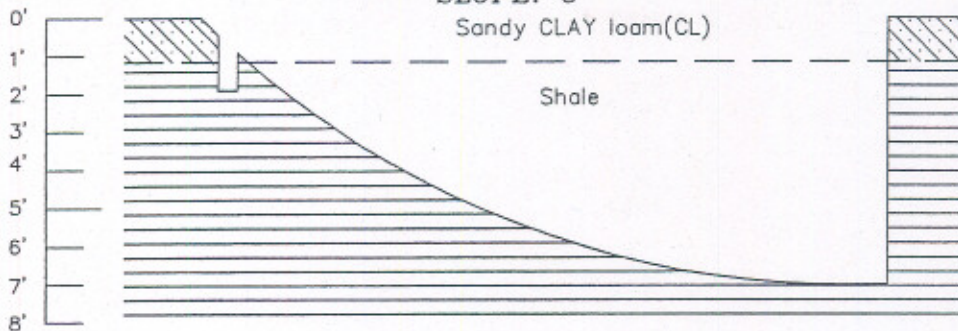

Sandy CLAY loam, soil, heavy roots to approximately 2", lesser roots to 2', light brown to 7.5 YR 6/4, moderate dry strength

Shale, thin bedded with soil and clay bedding plane filling to full depth of trench, clay material at 2.5' is mostly reddish 2.5 YR 4/4, fat clay that is moist below depth of 30", shale N10°W, 86°E

14" to 24": Very weathered shale, beds <1", rock is very weathered, abundant infilling of soil, dry

24" to 7': Shale beds are 1"-3" thick, slightly weathered

FEET BELOW
GROUND SURFACE

TP-2
N 13° W →
SLOPE: 3°

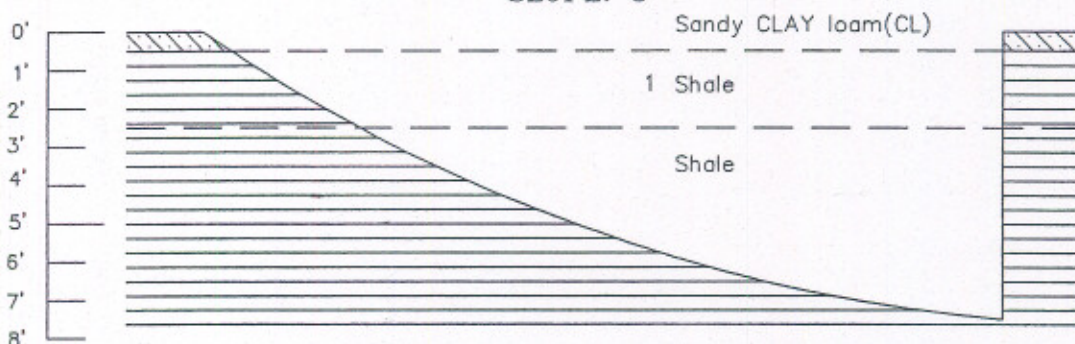

Sandy CLAY loam, soil, heavy roots to 3", lesser roots to 2', dry, light brown 7.5 YR 5/2, moderate dry strength, very porous, many shale fragments 1/4" thick and 2"-4" long

Mixture of weathered broken shale and soil from above

Shale thin beds, 1/4" to 2", all planes of fractures filled with light red 2.5 YR 6/6 fat clay, moist, soil from above, shale N11°E, 57°E

1: Shale layers generally less than 1", many fractures, all bedding planes and fractures filled with soil, dry

FEET BELOW
GROUND SURFACE

TP-3
N 14° E →
SLOPE: 6°

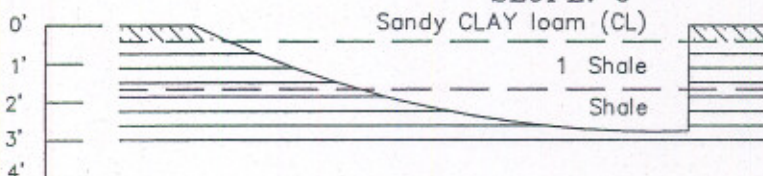

Sandy CLAY loam, dry, light red-brown, 5 YR 6/3, heavy roots to 2", many roots to 18"

Broken shale, beds commonly 2"

Shale, becomes fresh, refusal at 33". Local small lenses sandstone fine to medium grained quartz and feldspar. fracture filling, moist at 24", shale N05°W, 89°E

1: Very weathered with all bedding planes and fractures filled with dry soil from above. Less weathered with depth



HORIZONTAL SCALE: 1" = 5'



VERTICAL SCALE: 1" = 5'

S:\AEG DOCUMENTS\ONE\ONE TP PROFILE VIEWS.DWG(22)

APPPLIED
ENGINEERING AND
GEOLGY, INC.

P.O. BOX 247, LINCOLN, CA 95648
(916) 645-6014 (916) 645-6098 FAX

PROFILES OF TEST PITS TP-1 - TP-3
IONE RANCHERIA
PLYMOUTH, AMADOR COUNTY, CALIFORNIA

FIGURE A-1

S:\AEG DOCUMENTS\VONE\TP PROFILE VIEWS\DMG(22)

PROFILES OF TEST PITTS TP-4 - TP-5
 IONE RANCHERIA
 PLYMOUTH, AMADOR COUNTY, CALIFORNIA

FIGURE A-2

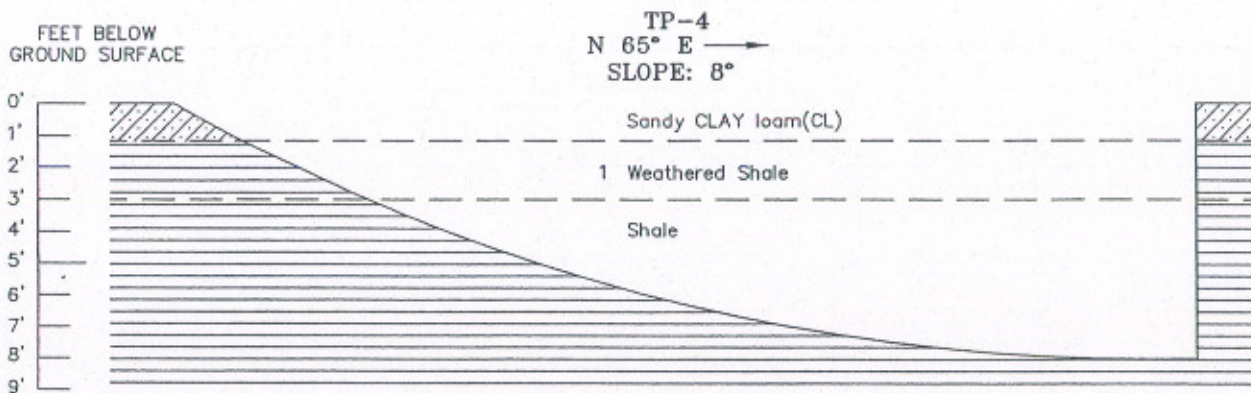

Sandy CLAY loam, soil, moderate to high dry strength, dry, pale brown 10 YR 6/3, very porous, heavy roots to 2", many roots to 18", many shale fragments throughout.

Shale beds have been tilted downslope. Breakage and parting along bedding planes. Shale, 1"-2" thick with moist red clay fracture filling. A fault at 8' from Northeast end, gouge is very moist, olive brown 2.5 YR 5/4, fat clay.

1: Mixed very broken weathered shale and soil from above

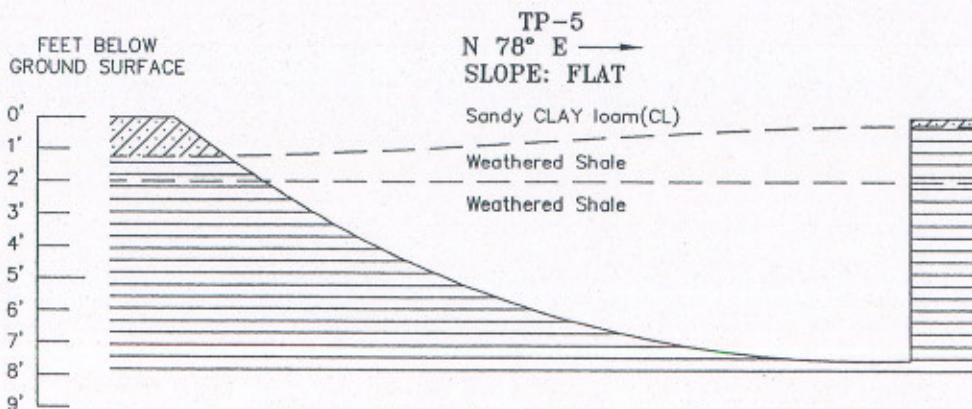

Sandy CLAY loam, soil, medium dry strength, red-grey 5 YR 5/2, dry. Heavy roots to 2", porous, many roots to 12" below soil layer, locally to 24"

Shale, thin beds with heavy infilling of soil, weathered shale. Middle of trench - soil to 2", fresh hard shale from 2" to 4'

West end: soil to 15" then thin broken weathered shale to 7.5. Heavy infilling of soil in this weathered shale. Approximately upper 3" of shale tilted to the West (downslope).

Fault with gouge, 2.5 YR 5/4 olive brown in west end, N 20° W, near vertical, fault in middle at N09E, 70W

Shale N15°W, 56°E

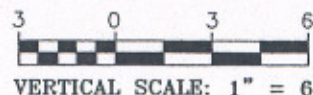
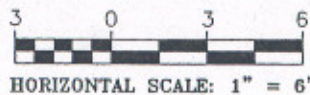

FEET BELOW
GROUND SURFACE

TP-6
N 20° E →
SLOPE: 20°

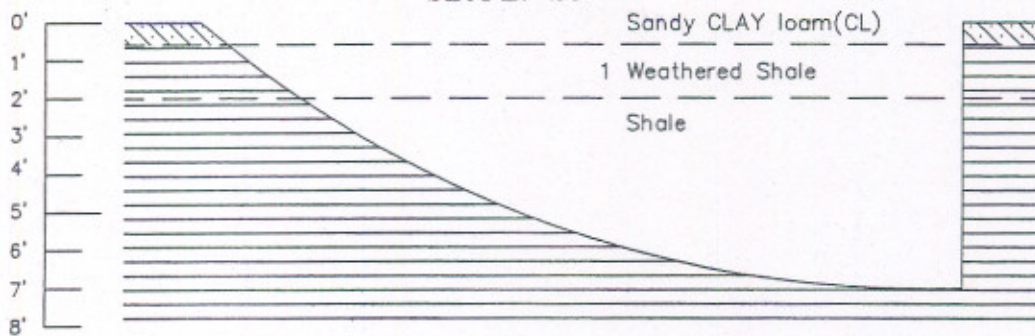

Sandy CLAY loam, light red-brown 5 YR 6/3 dry, moderate to high dry strength, heavy roots to 4".

Very porous, rock is mostly small fragments - 1/2" to 6"

Shale beds 1"-3", moderately weathered, abundant infilling with soil to full depth of the trench. 1" sandstone bed at 3.5' in middle of trench, a bed within shale - red, fat, clay 2.5 YR 4/6 at 3.5' deep in the middle of the trench.

Shale N20°E, 41°SE

1: Weathered shale mixed with soil from above.

FEET BELOW
GROUND SURFACE

TP-7
N 78° E →
SLOPE: 2°

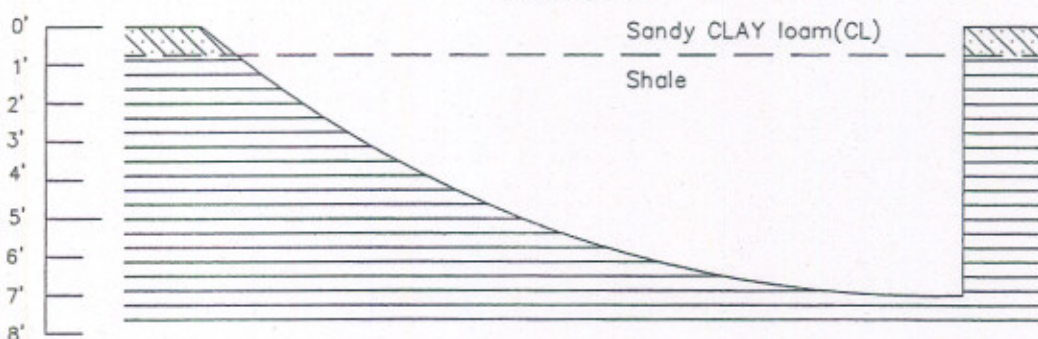

Sandy CLAY loam, abundant roots to full depth, red-gray 5 YR 5/2, dry, high dry strength

Shale, thin beds 1/2"-2" with soil in bedding planes to total depth. Upper 3' tilt down slope

Shale N03E, 80W

FEET BELOW
GROUND SURFACE

TP-8
N 9° W →
SLOPE: 4°

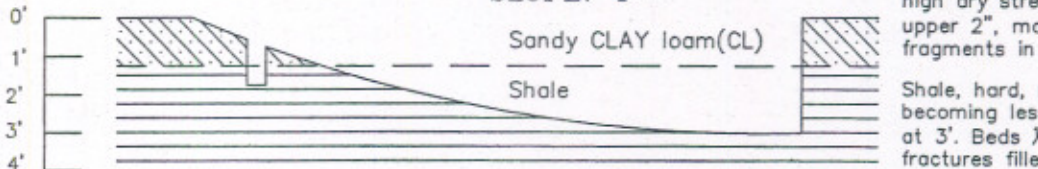

Sandy CLAY loam, gray 5 YR 6/2, dry, high dry strength, porous, heavy roots in upper 2", many roots to 20", many shale fragments in soil zone

Shale, hard, moderately weathered, becoming less weathered with depth, refusal at 3'. Beds 1/4" to 2". Bedding planes and fractures filled with soil from above.

Shale N04E, 81NW

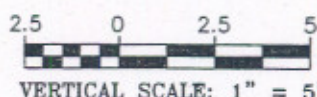
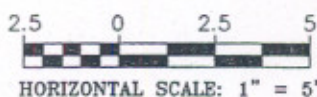

S:\AEG DOCUMENTS\IONE\IONE TP PROFILE VIEWS.DWG(22)

A PPLIED
E NGINEERING AND
G EOLOGY, INC.

P.O. BOX 247, LINCOLN, CA 95648
(916) 645-6014 (916) 645-6098 FAX

PROFILES OF TEST PITS TP-6 - TP-8
IONE RANCHERIA
PLYMOUTH, AMADOR COUNTY, CALIFORNIA

FIGURE A-3

FEET BELOW
GROUND SURFACE

TP-9
S 58° E →
SLOPE: 6°

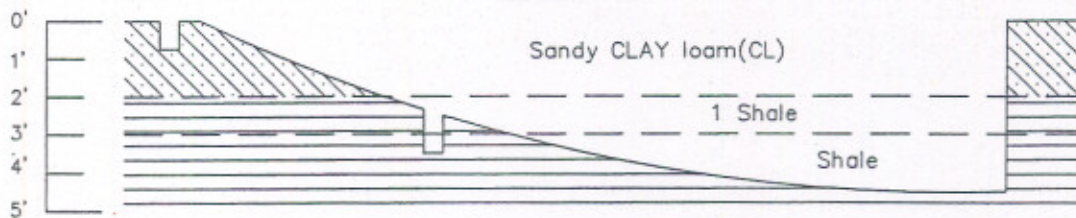

Sandy CLAY loam, gray
5 YR 6/2, dry, high dry
strength, very porous,
polished on sides at
depth of 18"
Planes and fractures filled
with soil from above
Shale, hard, black, refusal
at 4.5'

1: Shale, very broken, very weathered

FEET BELOW
GROUND SURFACE

TP-10
S 35° E →
SLOPE: 1°

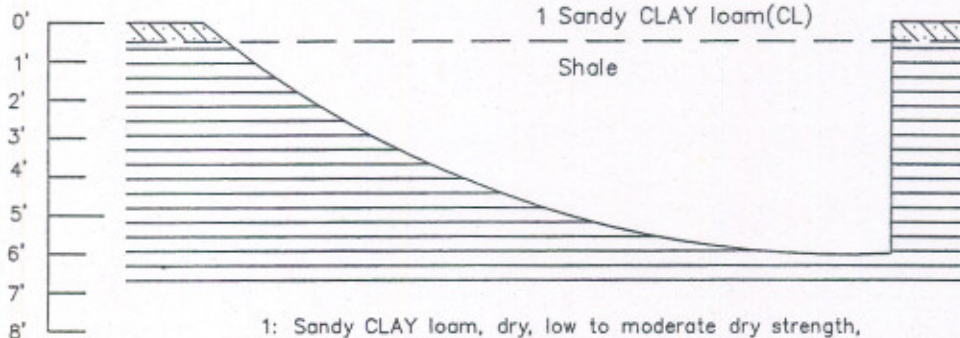

Very porous, abundant rock
fragments throughout. Heavy roots
to 2", many roots to 30"

Shale, thin beds 1/8" to 2", broken,
planes and fractures filled with soil
from above, very weathered to 6',
hard at 6', very thin red clay on
planes from 4'-6". Several thin (1/2"
to 1") sandstone beds in bottom
of trench, very fine sand

Shale N20°W, 70°E

1: Sandy CLAY loam, dry, low to moderate dry strength,
yellow - brown 10 YR 5/4

FEET BELOW
GROUND SURFACE

TP-10A
N 57° E →

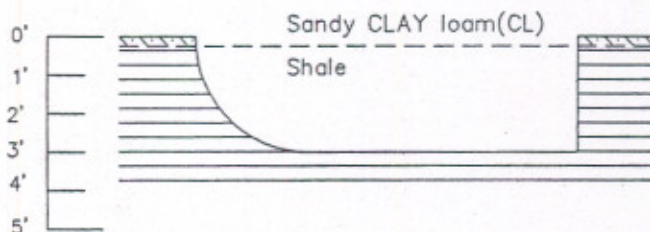

Sandy CLAY loam, dry

Shale, very broken, weathered, intermixed with soil from above

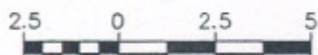

HORIZONTAL SCALE: 1" = 5'



VERTICAL SCALE: 1" = 5'

S:\AEG DOCUMENTS\IONE\IONE TP PROFILE VIEWS.DWG(22)

A PPLIED
E NGINEERING AND
G EOLOGY, INC.

P.O. BOX 247, LINCOLN, CA 95648
(916) 645-6014 (916) 645-6098 FAX

PROFILES OF TEST PITS TP-9 - TP-10A
IONE RANCHERIA
PLYMOUTH, AMADOR COUNTY, CALIFORNIA

FIGURE A-4

FEET BELOW
GROUND SURFACE

TP-10B
N 60° E →

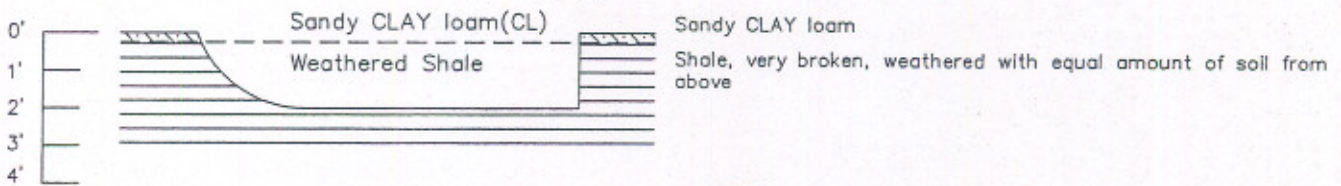

FEET BELOW
GROUND SURFACE

TP-11
S 68° E →
SLOPE: 3°

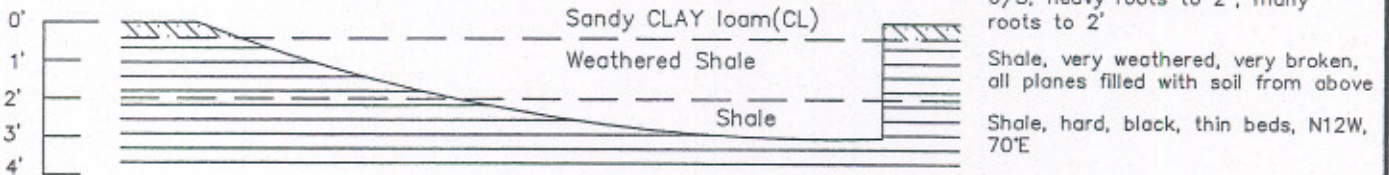

SEE FOLLOWING PAGE FOR TP-12

FEET BELOW
GROUND SURFACE

TP-12A
N 60° E →

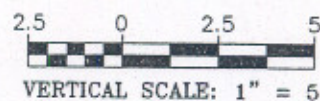
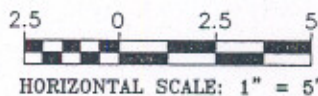
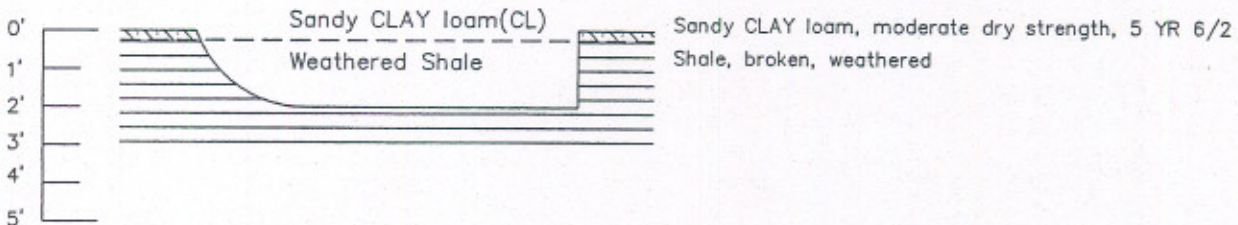

S:\AEG DOCUMENTS\IONE\ONE TP PROFILE VIEWS.DWG(22)

A PPLIED
E NGINEERING AND
G EOLOGY, INC.

P.O. BOX 247, LINCOLN, CA 95648
(916) 645-8014 (916) 645-6098 FAX

PROFILES OF TEST PITS TP-10B - TP-12A
IONE RANCHERIA
PLYMOUTH, AMADOR COUNTY, CALIFORNIA

FIGURE A-5

PROFILES OF TEST PITS TP-12 - TP-13

IONE RANCHERIA
PLYMOUTH, AMADOR COUNTY, CALIFORNIA

FIGURE A-6

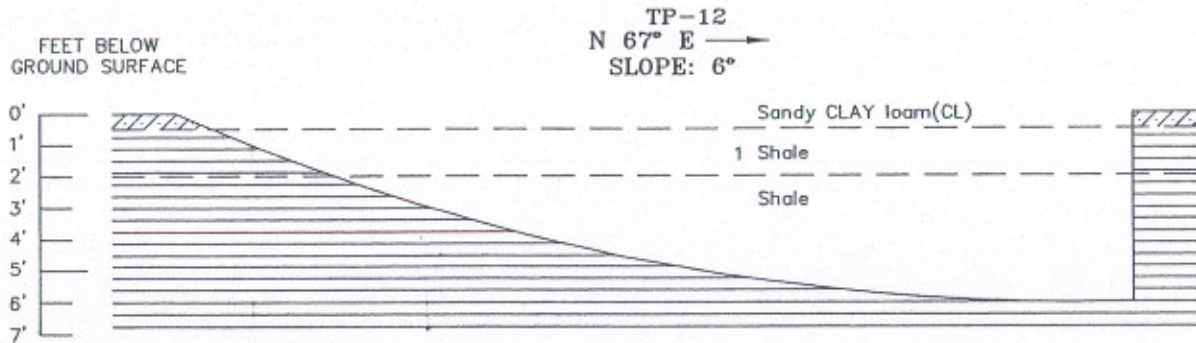

Sandy CLAY loam, dry, moderate dry strength, pink-gray 5 YR 6/2
Beds tilted downslope in upper 3' bedding plane fault 19' from deep end
Shale, less to unweathered, thin beds, planes filled with clay - often red, fat, another bedding plane fault approximately 6' to NE, filled with fat red clay

1: Shale, very weathered, very broken, planes all filled with soil from above,

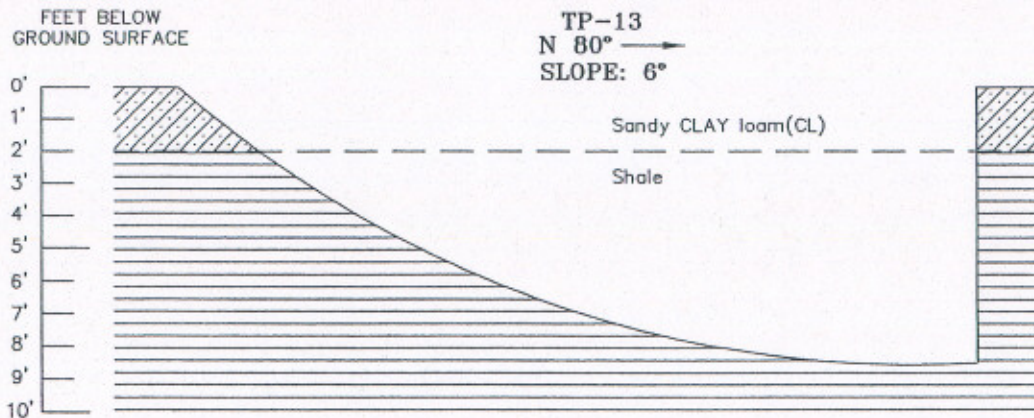

Sandy CLAY loam, dry, moderate dry strength, 5 YR 6/2, heavy roots to 2", many roots to 2'

Shale, very weathered, very broken, upper 3.5' tilted downslope. Local areas where material is almost a phyllite. Local clay, fat, red 2.5 YR 4/8, moist.

Shale N20°E, 25°E

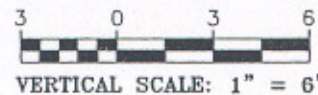
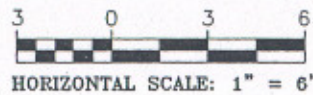

FEET BELOW
GROUND SURFACE

TP-12B
N 60° E →

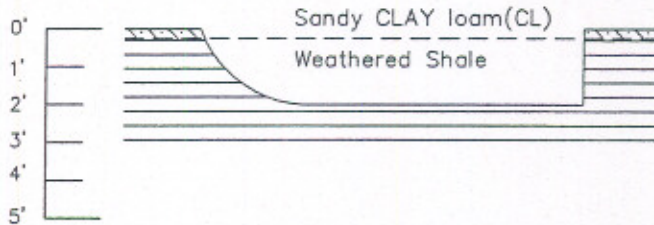

Sandy CLAY loam, moderate dry strength, 5 YR 6/2
Shale, broken, weathered

SEE PREVIOUS PAGE FOR TP-13

FEET BELOW
GROUND SURFACE

TP-13A
N 50° W →

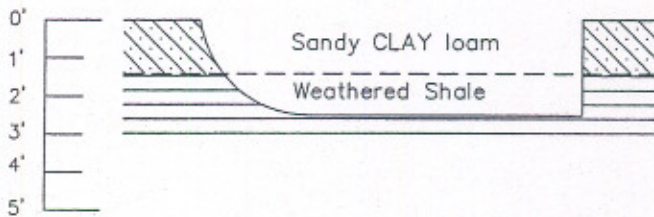

Sandy CLAY loam with broken shale fragments, moderate dry strength
Shale, broken, weathered

FEET BELOW
GROUND SURFACE

TP-13B
N 40° W →

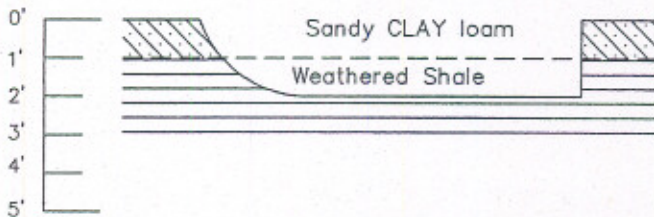

Sandy CLAY loam with broken shale, moderate dry strength
Shale, broken, weathered

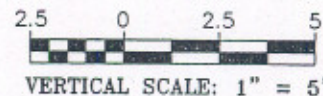
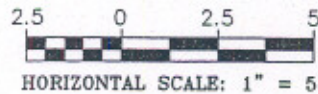

S:\AEG DOCUMENTS\IONE\IONE TP PROFILE VIEWS.DWG(22)

A PPLIED
E NGINEERING AND
G EOLOGY, INC.

P.O. BOX 247, LINCOLN, CA 95648
(916) 645-6014 (916) 645-6098 FAX

PROFILES OF TEST PITS TP-12B - TP-13B

IONE RANCHERIA

PLYMOUTH, AMADOR COUNTY, CALIFORNIA

FIGURE A-7

FEET BELOW
GROUND SURFACE

TP-14
N 40° E
SLOPE: 4°

Sandy CLAY loam, weak dry strength, dry, red-gray 5 YR 5/2, abundant roots to 3", many roots to 2"

Shale, very weathered, very broken, thin beds 1/8"-1", several faults, most bedding plane faults. Fault 10' from North East end, N 16° W

Shale N08W, 77E

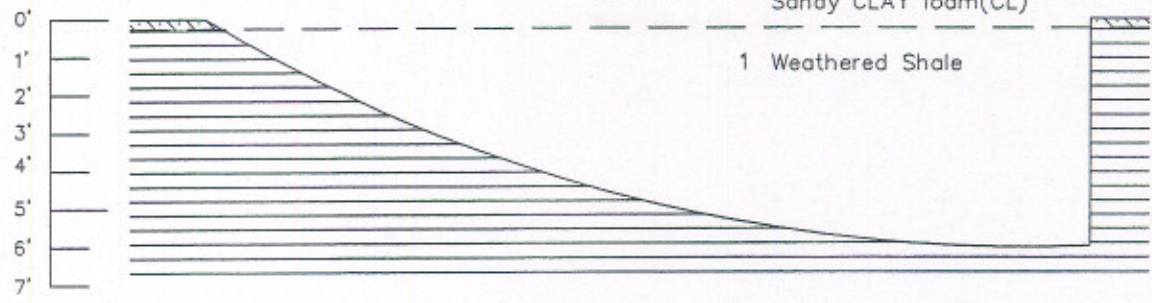

1: Upper 2' of shale tilted upslope on NE end of trench. Contorted area on Southeast wall at approximately N 16° W fault, beds are broken, bent, almost appears to be soil zone at approximately 15" bgs, a part of the fault? landslide?

FEET BELOW
GROUND SURFACE

TP-15
S 69° W
SLOPE: 6°

Sandy CLAY loam, dry, moderate dry strength, light red-brown 5 YR 6/3, heavy roots to 2", many roots to 2"

Beds tilt downslope in upper 2'

Shale, less weathered but with seams of red clay with roots to total depth, darker color, more massive

Shale N05E, 42SE

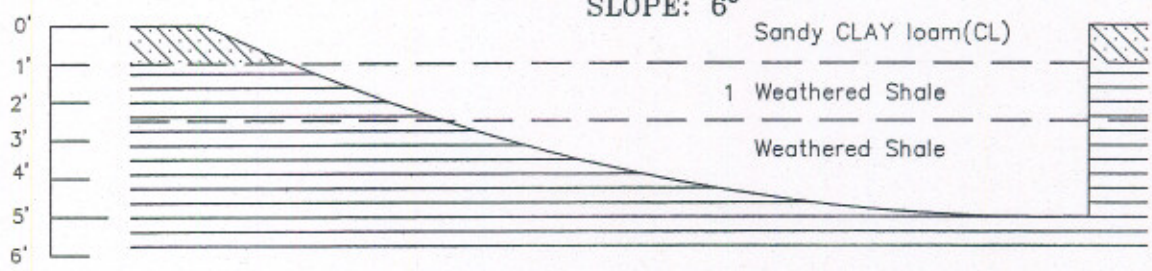

1: Shale, very weathered, mostly thin bedded, fractures and planes filled with soil from above.

FEET BELOW
GROUND SURFACE

TP-16
N 62° E
SLOPE: 3°

Sandy CLAY loam, moderate dry strength, dry, heavy roots to 2", many roots to 2"

Shale, very weathered, thin beds, heavy infilling with soil from above and with red clay. Beds bend, appears to be result of sliding when material was still not fully consolidated, N09W, 48NE

Shale, black, less weathered

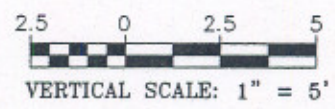
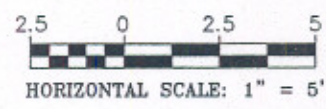
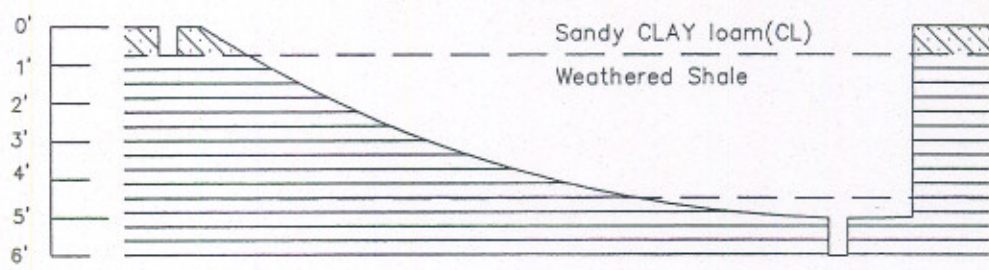

S:\AEG DOCUMENTS\IONE\IONE TP PROFILE VIEWS.DWG(22)

A PPLIED
E NGINEERING AND
G EOLOGY, INC.
P.O. BOX 247, LINCOLN, CA 95648
(916) 645-6014 (916) 645-6098 FAX

PROFILES OF TEST PITS TP-14 - TP-16
IONE RANCHERIA
PLYMOUTH, AMADOR COUNTY, CALIFORNIA

FIGURE A-8

FEET BELOW
GROUND SURFACE

TP-17
N 32° E →
SLOPE: 1°

Sandy CLAY loam, pink-gray
7.5 YR 7/2, moderate dry
strength, heavy roots to 2",
many roots to 3', many
rock fragments, dry.

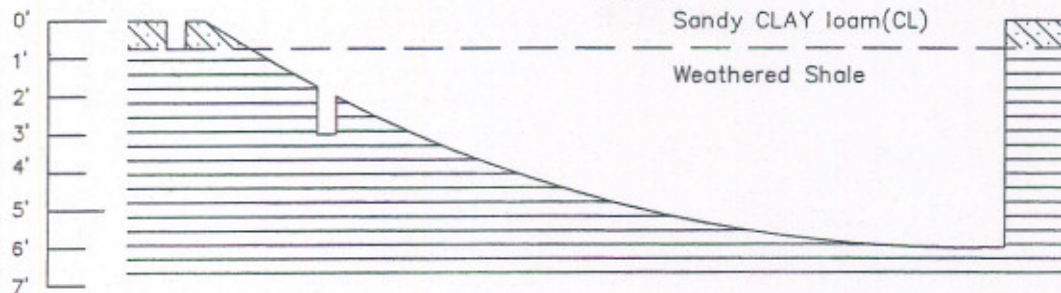

Shale, very broken, very
weathered, thin beds
1/8"-1", several bends in
beds, probably in partially
consolidated rock, abundant
red clay infilling as well as
soil from above. Red clay
appears to be along bedding
planes.

Shale N15°W, 62°SW

FEET BELOW
GROUND SURFACE

TP-18
N 38° E →
SLOPE: FLAT

Soil, pinkish 5 YR 7/3, dry,
moderate dry strength,
abundant roots to 18",
many roots to 3'

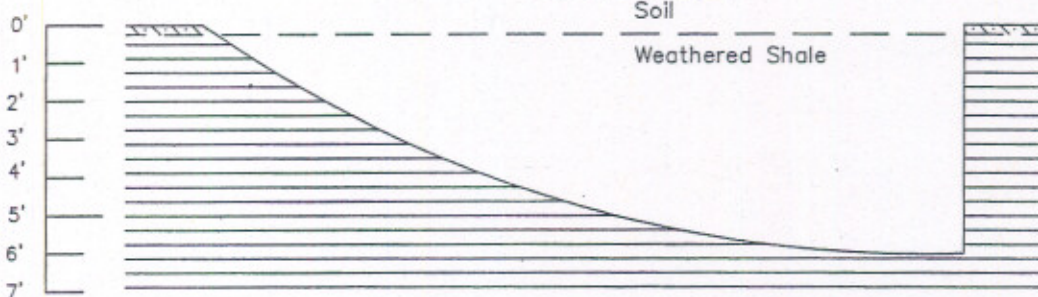

Shale, very weathered, very
broken planes filled with soil
N3°E 35' from above and
with red clay which is along
bedding at approximately 3'
bgs. Bedding contorted and
broken N05E, 43NW

FEET BELOW
GROUND SURFACE

TP-19
N 67° E →
SLOPE: 2°

Sandy CLAY loam, heavy roots
to 2", many roots to 2', dry,
moderate dry strength,

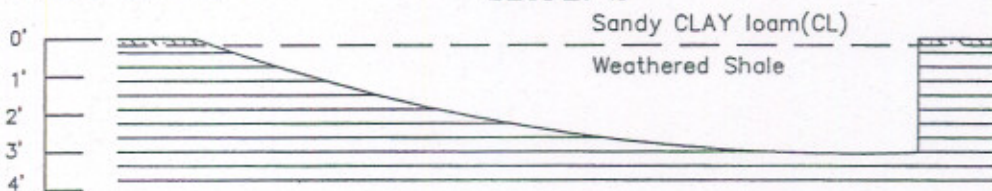

Shale, very broken, weathered,
slip plane with vertical
movement illustrated by angle
of bedding N0°W, 86E

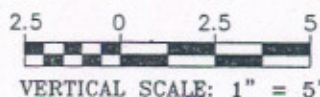
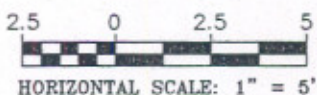

S:\AEG DOCUMENTS\NONE\ONE TP PROFILE VIEWS.DWG(22)

A PPLIED
E NGINEERING AND
G EOLOGY, INC.

P.O. BOX 247, LINCOLN, CA 95648
(916) 645-6014 (916) 645-6098 FAX

PROFILES OF TEST PITS TP-17 - TP-19
IONE RANCHERIA
PLYMOUTH, AMADOR COUNTY, CALIFORNIA

FIGURE A-9

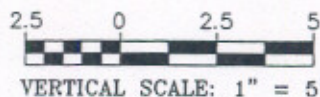
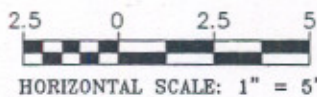
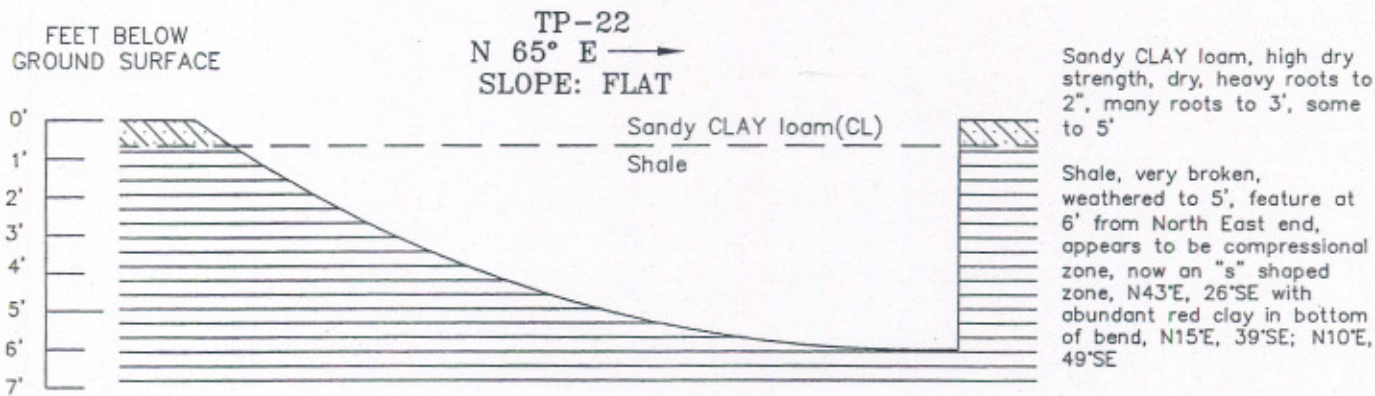
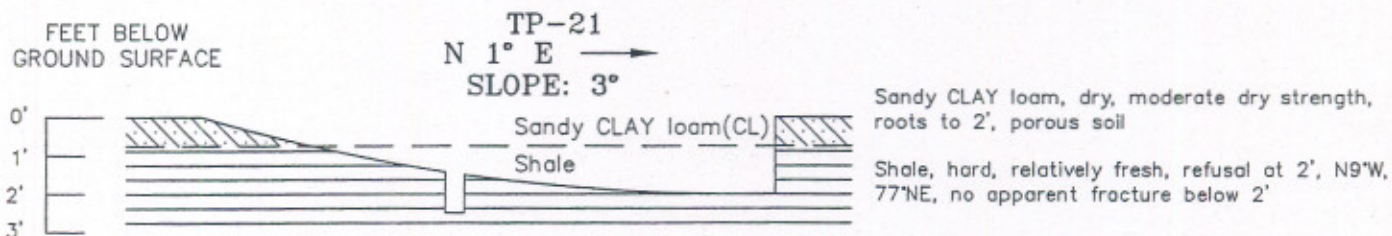
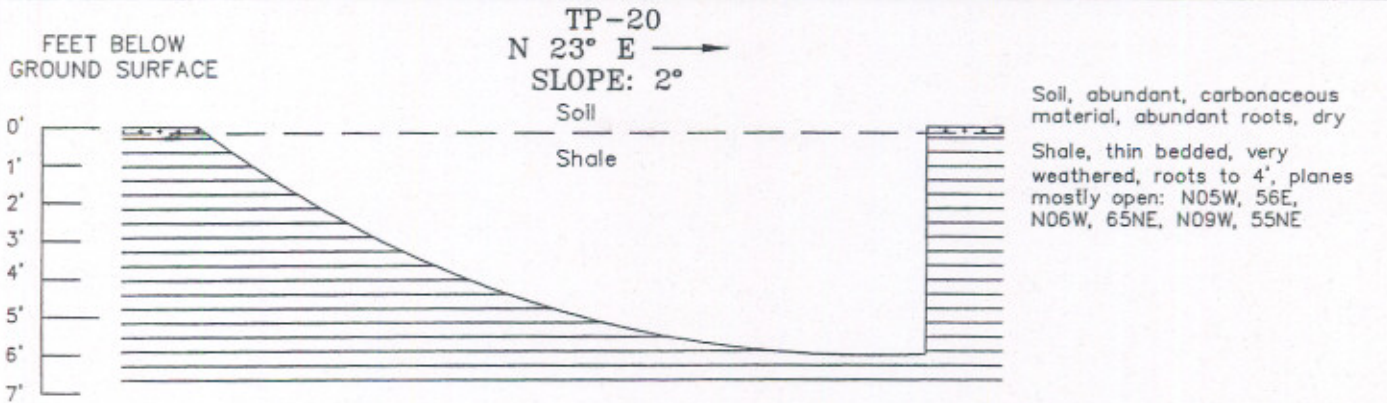

S:\AEG DOCUMENTS\IONE\IONE TP PROFILE VIEWS.DWG(22)

A PPLIED
E NGINEERING AND
G EOLOGY, INC.

P.O. BOX 247, LINCOLN, CA 95648
(916) 645-6014 (916) 645-6098 FAX

PROFILES OF TEST PITS TP-20 - TP-22
IONE RANCHERIA
PLYMOUTH, AMADOR COUNTY, CALIFORNIA

FIGURE A-10

FEET BELOW
GROUND SURFACE

TP-23
N 65° E →
SLOPE: 3°

Sandy CLAY loam, dry,
moderate dry strength,
heavy roots to 2", many
roots to 2'

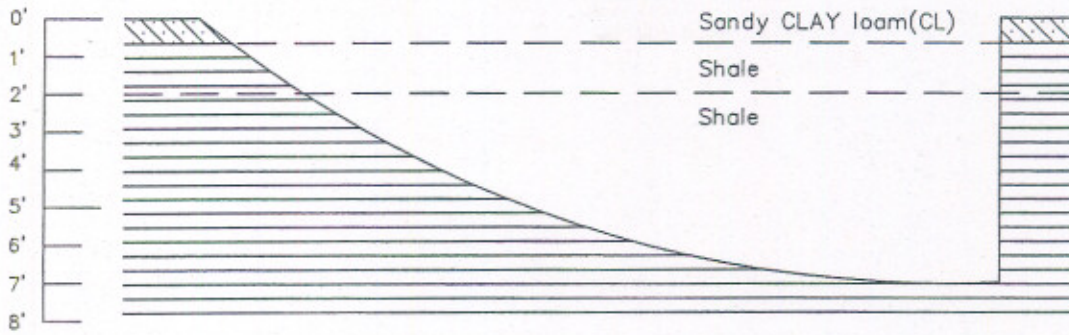

Shale, very broken, thin
beds tilted downlope, N06W,
76NE

Shale, less weathered, more
massive, soil from above in
many, not all planes

FEET BELOW
GROUND SURFACE

TP-24
N 41° W →
SLOPE: 6°

Sandy CLAY loam, heavy
roots, dry

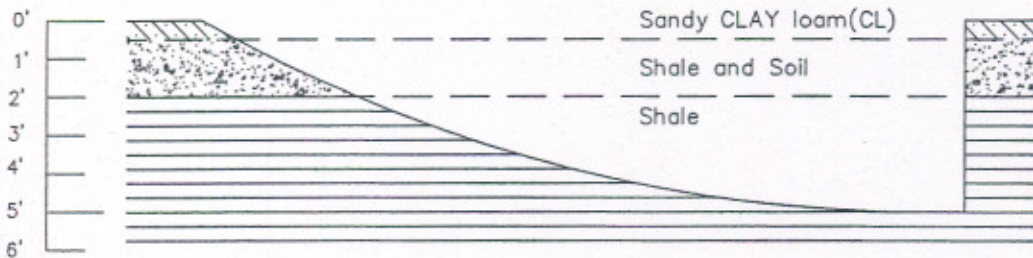

Mixed shale and soil as
above, many roots, shale
very weathered, broken

Shale, thicker beds 2"-4",
black, hard, N12°W, 57°NE,
much less weathered
sandstone beds to 1", fine
sand, rusty appearance

FEET BELOW
GROUND SURFACE

TP-24A
N 44° E →

Organic soil
Shale, broken thin beds

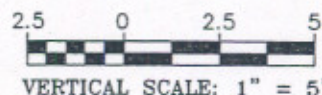
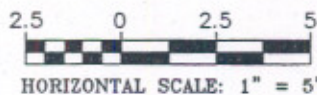
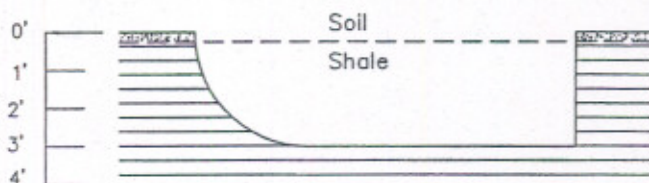

S:\AEG DOCUMENTS\NONE\NONE TP PROFILE VIEWS.DWG(22)

A PPLIED
E NGINEERING AND
G EOLOGY, INC.

P.O. BOX 247, LINCOLN, CA 95648
(916) 645-6014 (916) 645-6098 FAX

PROFILES OF TEST PITS TP-23 - TP-24A
IONE RANCHERIA
PLYMOUTH, AMADOR COUNTY, CALIFORNIA

FIGURE A-11

FEET BELOW
GROUND SURFACE

TP-24B
N 53° E →

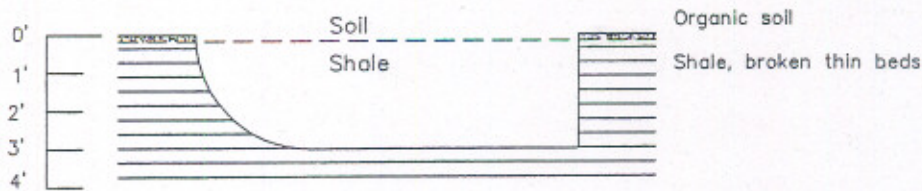

FEET BELOW
GROUND SURFACE

TP-25
N 48° W →
SLOPE: 5°

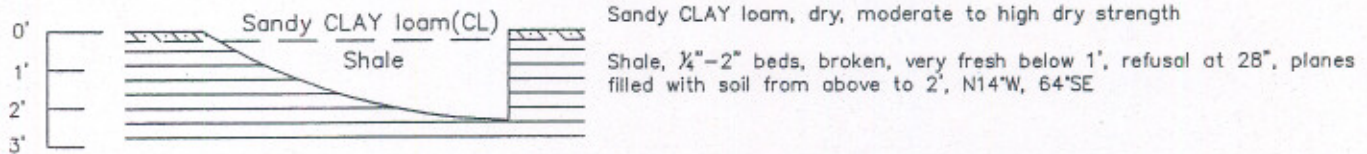

FEET BELOW
GROUND SURFACE

TP-26
N 81° W →
SLOPE: 10°

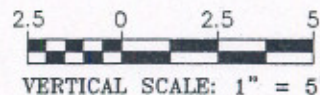
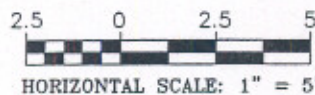
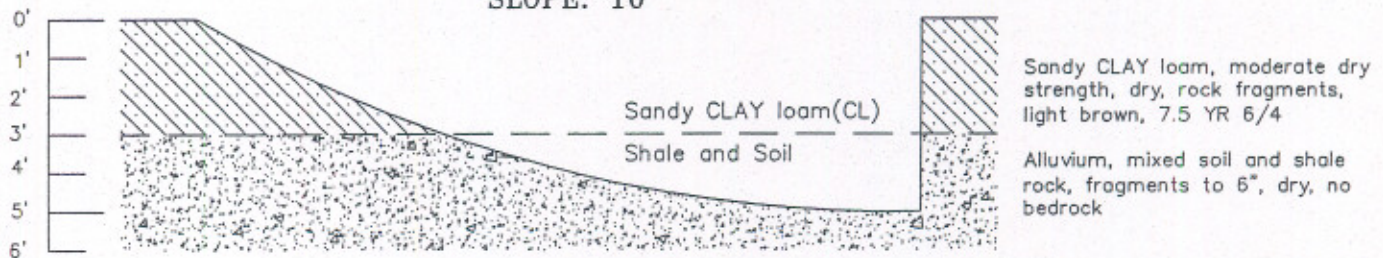

S:\AEG DOCUMENTS\JONE\JONE TP PROFILE VIEWS.DWG(22)

A PPLIED
E NGINEERING AND
G EOLOGY, INC.

P.O. BOX 247, LINCOLN, CA 95648
(916) 645-6014 (916) 645-6098 FAX

PROFILES OF TEST PITS TP-24B - TP-26
JONE RANCHERIA
PLYMOUTH, AMADOR COUNTY, CALIFORNIA

FIGURE A-12

FEET BELOW
GROUND SURFACE

TP-27
N 78° E →
SLOPE: 10°

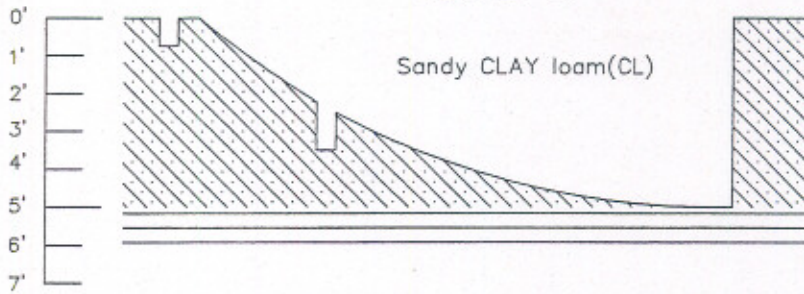

Sandy CLAY loam, very hard, with more digging found an attitude (barely any bedrock) N12°W, 75° NE, base firm hard shale, high dry strength, high polish on the sides, high clay content, light brown

Shale

FEET BELOW
GROUND SURFACE

TP-28
N 73° E →
SLOPE: 10°

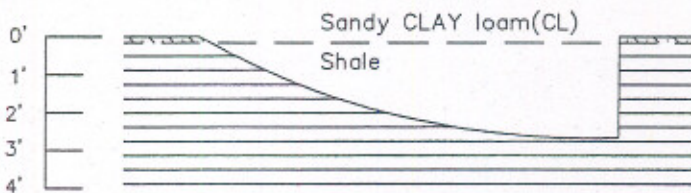

Sandy CLAY loam, low to moderate dry strength

Shale, 1/8"-1.5" beds, N18°W, 60°SW, shale is heavily fractured, soil filled fractures and bedding planes, very hard shale, no moisture, but some iron staining, one thin sandstone bed found, fine grained

FEET BELOW
GROUND SURFACE

TP-29
N 46° W →
SLOPE: 4°

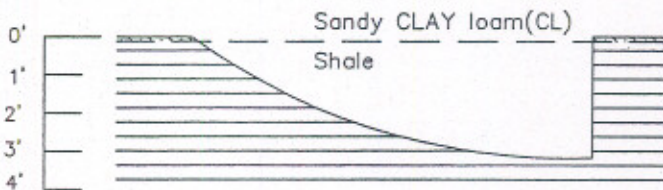

Sandy CLAY loam, very rich in organic matter

Shale, 1/6"-2" beds, some iron staining, soil filled fractures and bedding planes, N12°W, 56°SW (attitude on shale), appears to be sandstone filled fractures, roots extend to at least 2', slightly weathered at base, very hard shale

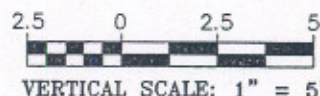
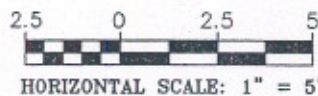

S:\AEG DOCUMENTS\ONE\ONE TP PROFILE MEWS.DWG(22)

A PPLIED
E NGINEERING AND
G EOLOGY, INC.

P.O. BOX 247, LINCOLN, CA 95648
(916) 645-6014 (916) 645-6098 FAX

PROFILES OF TEST PITS TP-27 - TP-29
IONE RANCHERIA
PLYMOUTH, AMADOR COUNTY, CALIFORNIA

FIGURE A-13

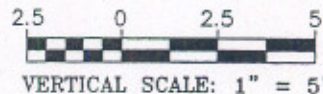
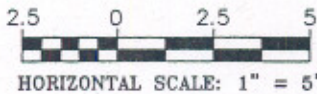
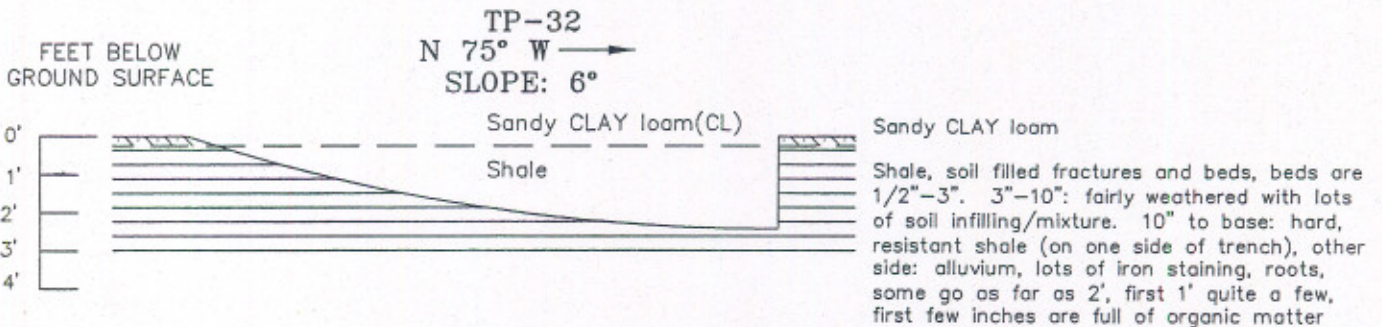
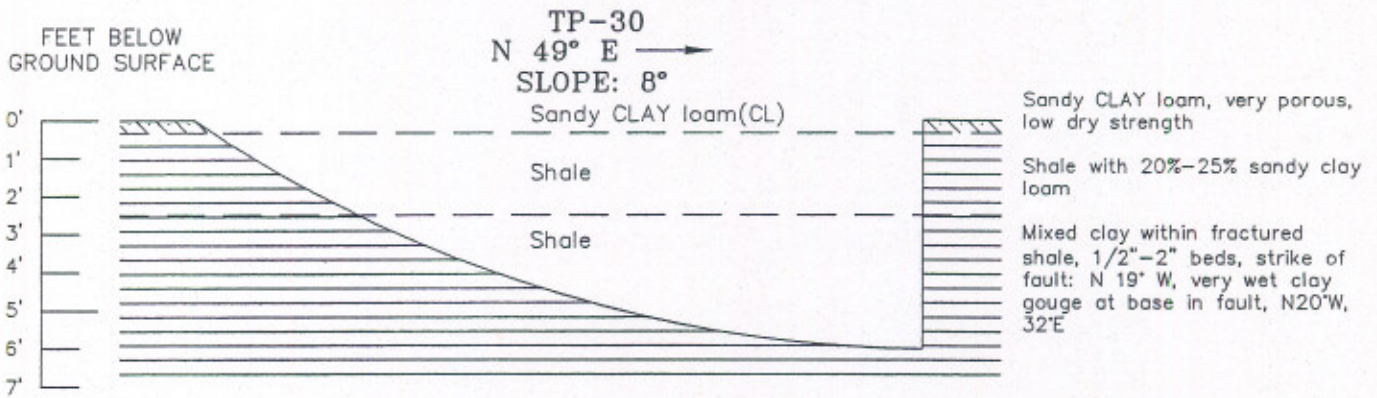

S:\AEG DOCUMENTS\IONE\IONE TP PROFILE VIEWS.DWG(22)

A APPLIED
E ENGINEERING AND
G GEOLOGY, INC.

P.O. BOX 247, LINCOLN, CA 95648
(916) 645-6014 (916) 645-6098 FAX

PROFILES OF TEST PITS TP-30 - TP-32
IONE RANCHERIA
PLYMOUTH, AMADOR COUNTY, CALIFORNIA

FIGURE A-14

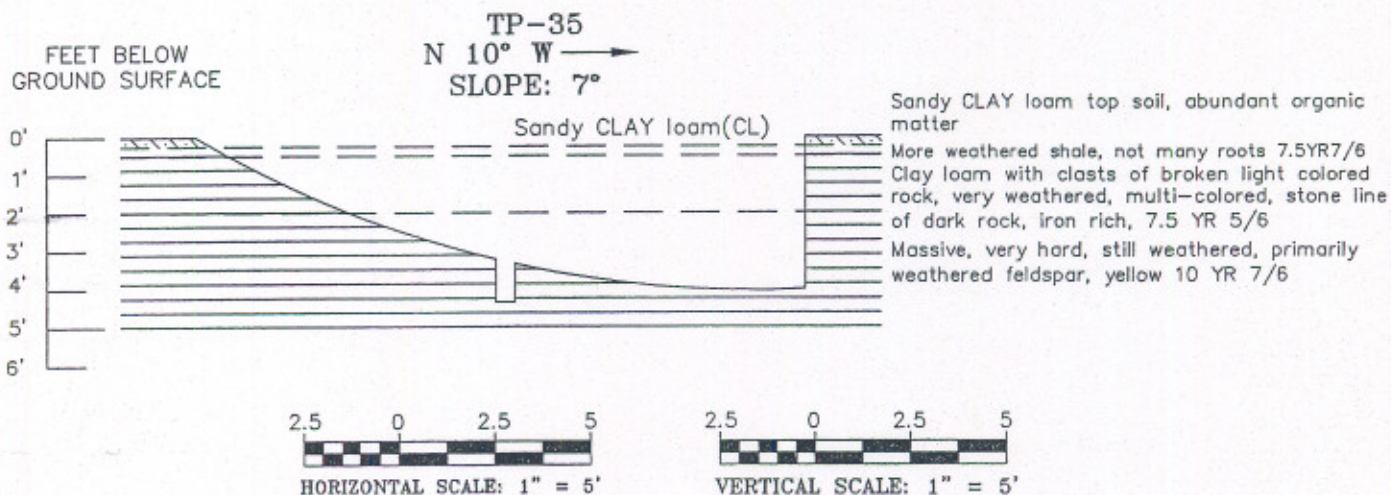
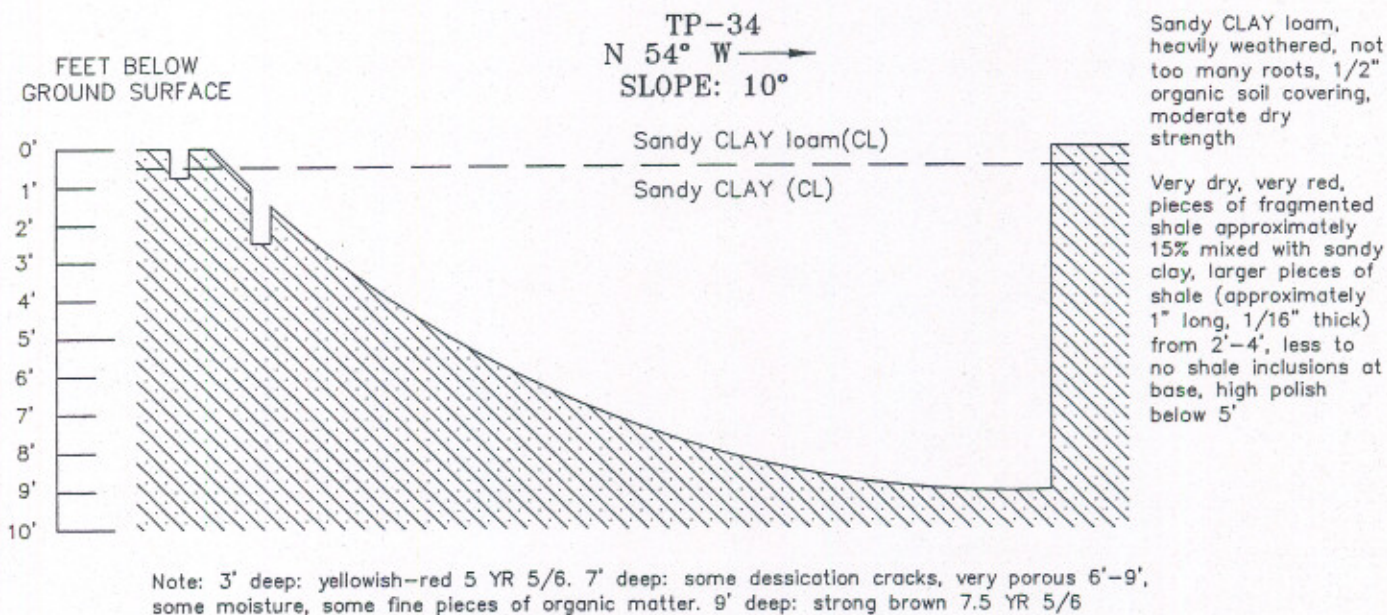
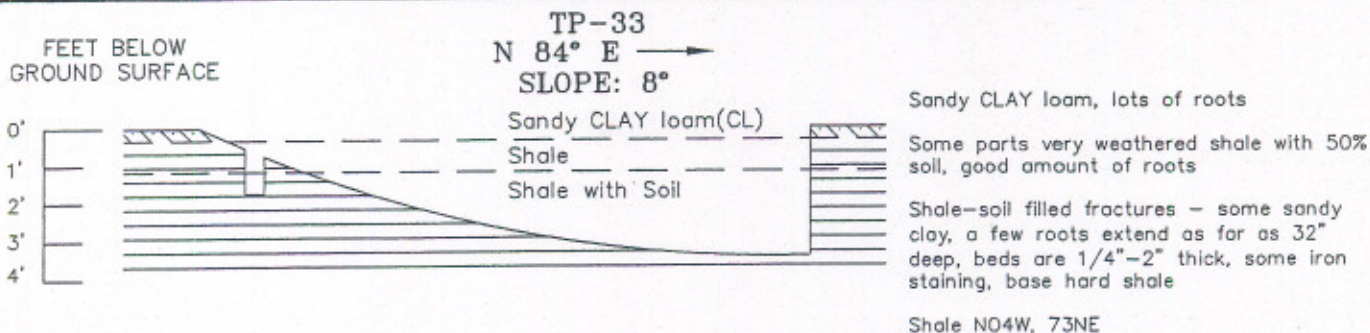

S:\AEG DOCUMENTS\IONE\IONE TP PROFILE VIEWS.DWG(22)

A PPLIED
E NGINEERING AND
G EOLOGY, INC.

P.O. BOX 247, LINCOLN, CA 95648
(916) 645-6014 (916) 645-6098 FAX

PROFILES OF TEST PITS TP-33 - TP-35
IONE RANCHERIA
PLYMOUTH, AMADOR COUNTY, CALIFORNIA

FIGURE A-15

Appendix B

Percolation Hole Data

TABLE B-1 Percolation Hole Data		
TP1S		
Test Operator: Bob	Comments: None	
Time	Water Depth	Water Added
0842	Dry: START	6.0 inches
0852	Dry	6.0 inches
0902	0.05 inches	5.95 inches
0912	0.1 inches	5.9 inches
0922	0.1 inches	5.9 inches
0924	4.1 inches	None
0926	2.6 inches	None
0928	1.5 inches	None
0930	0.7 inches	None
0931	0.4 inches	None
0932	0.1 inches	5.9 inches
0942	0.1 inches	5.9 inches
0952	0.05 inches	5.95 inches
1002	0.05 inches	5.95 inches
1004	4.1 inches	None
1006	2.6 inches	None
1008	1.5 inches	None
1010	0.7 inches	None
1011	0.4 inches	None
1012	0.05 inches	5.95 inches
1016	2.6 inches	None

TABLE B-1 Percolation Hole Data		
TP1S (continued)		
Test Operator: Bob	Comments: None	
Time	Water Depth	Water Added
1018	1.6 inches	None
1020	0.6 inches	None
1021	0.4 inches	None
1022	0.05 inches	5.95 inches
1024	4.25 inches	None
1026	2.7 inches	None
1028	1.6 inches	None
1030	0.7 inches	None
1031	0.4 inches	None
1032	0.1 inches	5.9 inches
1034	4.15 inches	None
1036	2.6 inches	None
1038	1.5 inches	None
1040	0.7 inches	None
1041	0.4 inches	None
1042	0.1 inches	5.9 inches
1044	4.1 inches	None
1046	2.55 inches	None
1048	1.5 inches	None
1050	0.7 inches	None
1051	0.4 inches	None

TABLE B-1		
Percolation Hole Data		
TP1S (continued)		
Test Operator: Bob	Comments: None	
Time	Water Depth	Water Added
1052	0.1 inches	END
TP8S		
Test Operator: Earl	Comments: None	
Time	Water Depth	Water Added
1119	Dry: START	6.0 inches
1139	1.8 inches	4.2 inches
1149	2.5 inches	3.5 inches
1159	2.6 inches	3.4 inches
1209	2.0 inches	4.0 inches
1219	2.7 inches	3.3 inches
1229	2.7 inches	3.3 inches
1239	1.5 inches	4.5 inches
1249	2.3 inches	3.7 inches
1259	2.9 inches	3.1 inches
1309	3.1 inches	2.9 inches
1329	3.0 inches	3.0 inches
1339	2.7 inches	3.3 inches
1340	2.7 inches	3.3 inches
1350	2.8 inches	END

TABLE B-1		
Percolation Hole Data		
TP9S		
Test Operator: Earl	Comments: None	
Time	Water Depth	Water Added
1450	Dry: START	6.0 inches: Dry at 1455
1500	Dry	6.0 inches: Dry at 1505
1510	Dry	6.0 inches
1520	Dry	6.0 inches
1530	Dry	6.0 inches
1540	Dry	6.0 inches
1550	Dry	END
TP9D		
Test Operator: Earl	Comments: None	
Time	Water Depth	Water Added
1451	Dry: Start	6.0 inches
1501	1.4 inches	4.6 inches
1511	2.1 inches	3.9 inches
1521	1.9 inches	4.1 inches
1531	2.6 inches	3.4 inches
1541	2.8 inches	3.2 inches
1554	1.3 inches	4.7 inches
1601	2.9 inches	3.1 inches
1611	2.2 inches	3.8 inches
1621	2.6 inches	3.4 inches
1631	2.5 inches	3.5 inches

TABLE B-1		
Percolation Hole Data		
TP9D (continued)		
Test Operator: Earl	Comments: None	
Time	Water Depth	Water Added
1641	2.4 inches	END
TP16S		
Test Operator: Ernie	Comments: None	
Time	Water Depth	Water Added
0937	Dry: START	6.0 inches
1007	4.5 inches	None
1037	3.5 inches	None
1109	2.0 inches	4.0 inches
1137	4.8 inches	None
1210	3.4 inches	None
1239	2.3 inches	None
1309	1.9 inches	5.1 inches
1339	4.2 inches	END
TP16D		
Test Operator: Ernie	Comments: None	
Time	Water Depth	Water Added
0939	Dry: START	6.0 inches
1009	4.7 inches	None
1039	3.5 inches	None
1111	2.0 inches	4.0 inches
1139	3.8 inches	None

TABLE B-1		
Percolation Hole Data		
TP16D (continued)		
Test Operator: Ernie	Comments: None	
Time	Water Depth	Water Added
1211	2.8 inches	None
1240	2.4 inches	None
1310	2.1 inches	None
1340	1.7 inches	END
TP17S		
Test Operator: Ernie	Comments: Water drained faster than could be added	
Time	Water Depth	Water Added
0947	Dry: START	6.0 inches
1017	Dry	END 6.0 inches drained in 65 sec
TP17D		
Test Operator: Ernie	Comments: None	
Time	Water Depth	Water Added
0945	Dry: START	6.0 inches
1015	3.0 inches	None
1025	1.7 inches	4.3 inches
1035	2.4 inches	None
1045	1.7 inches	4.3 inches
1055	2.4 inches	None
1105	1.6 inches	4.4 inches
1115	2.6 inches	None

TABLE B-1		
Percolation Hole Data		
TP17D (continued)		
Test Operator: Ernie	Comments: None	
Time	Water Depth	Water Added
1125	1.8 inches	4.2 inches
1135	2.4 inches	None
1145	1.7 inches	4.3 inches
1155	2.3 inches	None
1205	1.8 inches	4.2 inches
1215	2.4 inches	None
1225	1.8 inches	END
TP21S		
Test Operator: Ernie	Comments: None	
Time	Water Depth	Water Added
1207	Dry:START	6.0 inches
1235	Dry	6.0 inches
1245	0.1 inches	5.9 inches
1255	2.1 inches	None
1305	0.3 inches	5.7 inches
1315	1.6 inches	4.4 inches
1325	1.8 inches	4.2 inches
1335	2.1 inches	None
1345	1.0 inches	5.0 inches
1355	2.2 inches	3.8 inches
1405	0.8 inches	5.2 inches

TABLE B-1		
Percolation Hole Data		
TP21S (continued)		
Test Operator: Ernie	Comments: None	
Time	Water Depth	Water Added
1445	0.7 inches	5.3 inches
1455	2.5 inches	None
1505	1.0 inches	END
TP21D		
Test Operator: Ernie	Comments: Top of hole drained quickly horizontally.	
Time	Water Depth	Water Added
0950	Dry: START	6.0 inches
1208	.3 inches	5.7 inches
1237	4 inches	None
1257	3.9 inches	None
1317	2.0 inches	4.0 inches
1347	3.4 inches	None
1417	3.0 inches	None
1447	2.8 inches	None
1517	1.9 inches	4.1 inches
1547	3.5 inches	None
1617	3.8 inches	END

TABLE B-1
 Percolation Hole Data

TP27S		
Test Operator: Earl	Comments: None	
Time	Water Depth	Water Added
1126	Dry: START	6.0 inches
1146	5.2 inches	None
1216	5.0 inches	None
1247	4.0 inches	None
1316	3.6 inches	2.4 inches
1346	5.1 inches	None
1415	4.2 inches	None
1446	3.8 inches	2.2 inches
1516	5.4 inches	None
1546	4.7 inches	END
TP27D		
Test Operator: Earl	Comments: None	
Time	Water Depth	Water Added
1124	Dry: START	6.0 inches
1145	5.2 inches	None
1215	5.1 inches	None
1246	4.4 inches	None
1315	3.8 inches	2.2 inches
1345	5.1 inches	None
1415	4.9 inches	None
1445	4.6 inches	None

TABLE B-1		
Percolation Hole Data		
TP27D (continued)		
Test Operator: Earl	Comments: None	
Time	Water Depth	Water Added
1515	4.4 inches	None
1545	4.1 inches	END
PH31S¹		
Test Operator: Earl	Comments: None	
Time	Water Depth	Water Added
1137	Dry: START	6.0 inches
1203	Dry	6.0 inches
1213	1.2 inches	4.8 inches
1223	1.6 inches	4.4 inches
1233	1.9 inches	4.1 inches
1244	1.6 inches	4.4 inches
1255	1.6 inches	4.4 inches
1304	1.8 inches	4.2 inches
1313	2.0 inches	4.0 inches
1325	1.3 inches	4.7 inches
1336	1.8 inches	4.2 inches
1343	2.3 inches	3.7 inches
1354	1.7 inches	4.3 inches
1403	2.0 inches	4.0 inches
1415	2.0 inches	END

TABLE B-1 Percolation Hole Data		
PH31D¹		
Test Operator: Earl	Comments: None	
Time	Water Depth	Water Added
1132	Dry: START	6.5 inches
1202	Dry	6.0 inches
1212	0.6 inches	5.4 inches
1222	1.3 inches	4.7 inches
1232	1.6 inches	4.4 inches
1243	1.0 inches	5.0 inches
1254	1.3 inches	4.7 inches
1302	1.6 inches	4.4 inches
1312	2.0 inches	4.0 inches
1324	1.5 inches	4.5 inches
1335	1.8 inches	4.2 inches
1342	2.0 inches	4.0 inches
1353	1.8 inches	4.2 inches
1402	1.8 inches	4.2 inches
1412	1.7 inches	END

¹No Test Pit at this Location- Only a Percolation Hole (PH)

TABLE B-1		
Percolation Hole Data		
TP33S		
Test Operator: Bob	Comments: None	
Time	Water Depth	Water Added
1558	Dry: START	6.0 inches
1608	0.2 inches	5.8 inches
1618	1.55 inches	4.45 inches
1628	2.25 inches	3.75 inches
1638	2.25 inches	3.75 inches
1648	2.20 inches	3.80 inches
1658	2.15 inches	3.85 inches
1708	2.2 inches	3.8 inches
1718	2.15 inches	3.85 inches
1728	2.7 inches	3.3 inches
1738	2.5 inches	3.5 inches
1748	2.7 inches	3.3 inches
1758	2.6 inches	3.4 inches
1808	2.5 inches	3.5 inches
1818	2.4 inches	3.6 inches
1828	2.5 inches	END

TABLE B-1 Percolation Hole Data		
TP34S		
Test Operator: Bob	Comments: None	
Time	Water Depth	Water Added
1430	Dry: START	6.0 inches
1440	3.8 inches	2.2 inches
1450	4.1 inches	None
1500	2.85 inches	3.15 inches
1510	4.3 inches	None
1520	2.8 inches	3.2 inches
1530	4.3 inches	None
1540	2.95 inches	3.05 inches
1550	4.3 inches	None
1600	3.0 inches	3.0 inches
1605	5.1 inches	None
1610	4.15 inches	None
1620	2.9 inches	3.1 inches
1630	4.5 inches	None
1640	2.9 inches	3.1 inches
1650	4.85 inches	None
1652	4.30 inches	None
1654	4.00 inches	None
1656	3.9 inches	None
1700	3.2 inches	None
1702	3.1 inches	None

TABLE B-1		
Percolation Hole Data		
TP34S (continued)		
Test Operator: Bob	Comments: None	
Time	Water Depth	Water Added
1704	2.8 inches	None
1706	2.5 inches	None
1710	2.1 inches	None
1712	2.0 inches	None
1716	1.6 inches	None
1722	1.05 inches	None
1724	0.9 inches	None
1726	0.6 inches	END
TP34D		
Test Operator: Bob	Comments: Final draw down of 3 minute 22 seconds	
Time	Water Depth	Water Added
0937	Dry: START	6.0 inches
1005	Dry	6.0 inches
1015	Dry	6.0 inches
1026	Dry	6.0 inches
1037	Dry	6.0 inches
1047	Dry	6.0 inches
1100	Dry	6.0 inches
1111	Dry	6.0 inches
1125	Dry	6.0 inches
1134	Dry	6.0 inches

TABLE B-1		
Percolation Hole Data		
TP34D (continued)		
Test Operator: Bob	Comments: Final draw down of 3 minute 22 seconds	
Time	Water Depth	Water Added
1135.5	2.0 inches	None
1137.5	Dry	None
1201	Dry	6.0 Inches
1204:22	Dry	END
TP35S		
Test Operator: Bob	Comments: None	
Time	Water Depth	Water Added
1302	Dry: START	6.0 inches
1314	0.2 inches	5.8 inches
1324	0.7 inches	5.3 inches
1334	1.05 inches	4.95 inches
1344	0.9 inches	5.1 inches
1354	0.6 inches	5.4 inches
1404	0.7 inches	5.3 inches
1414	0.6 inches	5.4 inches
1424	0.7 inches	5.3 inches
1434	0.7 inches	5.3 inches
1444	0.6 inches	5.4 inches
1454	0.7 inches	5.3 inches
1504	0.7 inches	5.3 inches
1514	0.75 inches	5.25 inches

TABLE B-1		
Percolation Hole Data		
TP35S (continued)		
Test Operator: Bob	Comments: None	
Time	Water Depth	Water Added
1524	0.7 inches	5.3 inches
1534	0.75 inches	END
TP35D		
Test Operator: Bob	Comments: None	
Time	Water Depth	Water Added
0944	Dry: START	6.0 inches
1010	5.5 inches	None
1020	5.3 inches	None
1032	4.8 inches	None
1042	4.8 inches	None
1052	4.8 inches	None
1104	4.8 inches	None
1119	4.5 inches	None
1132	4.5 Inches	None
1151	4.4 inches	None
1221	4.1 inches	None
1303	3.2 inches	2.8 inches
1333	5.8 inches	None
1345	5.7 inches	None

TABLE B-1 Percolation Hole Data		
TP35D (continued)		
Test Operator: Bob	Comments: None	
Time	Water Depth	Water Added
1415	5.1 inches	None
1445	4.7 inches	None
1515	4.3 inches	None
1545	3.7 inches	2.3 inches
1615	5.5 inches	None
1645	5.05 inches	None
1715	4.65 inches	END

TP = Test Pit
PH = Percolation Hole

Appendix C

Trench Percolation Test Results

TABLE C-1

Trench Percolation Test Results

Trench	Test Date	Test Pit Depth (inches)	Approximate Surface Area (square feet)	Amount of Water Added (gallons)	Time During test	Elapsed Time (minutes)	Depth to Water (feet)	Results/Notes
TP-10A	10/29/03	24.0	80	180	1238	0	1.3	-No seepage into adjacent trenches -Infiltration Rate = (180 gal/80 square feet)/46 minutes x 1440 = (70 gal/square feet)/day
TP-10A	10/29/03	24	80	180	1239	1	1.26	
TP-10A	10/29/03	24	80	180	1240	2	1.12	
TP-10A	10/29/03	24	80	180	1241	3	1.06	
TP-10A	10/29/03	24	80	180	1242	4	1.02	
TP-10A	10/29/03	24	80	180	1243	5	0.99	
TP-10A	10/29/03	24	80	180	1244	6	0.95	
TP-10A	10/29/03	24	80	180	1245	7	0.91	
TP-10A	10/29/03	24	80	180	1246	8	0.88	
TP-10A	10/29/03	24	80	180	1247	9	0.855	
TP-10A	10/29/03	24	80	180	1248	10	0.82	

TABLE C-1
 Trench Percolation Test Results

Trench	Test Date	Test Pit Depth (inches)	Approximate Surface Area (square feet)	Amount of Water Added (gallons)	Time During test	Elapsed Time (minutes)	Depth to Water (feet)	Results/Notes
TP-10A	10/29/03	24	80	180	1249	11	0.795	
TP-10A	10/29/03	24	80	180	1250	12	0.78	
TP-10A	10/29/03	24	80	180	1251	13	0.75	
TP-10A	10/29/03	24	80	180	1252	14	0.735	
TP-10A	10/29/03	24	80	180	1253	15	0.71	
TP-10A	10/29/03	24	80	180	1254	16	0.685	
TP-10A	10/29/03	24	80	180	1255	17	0.665	
TP-10A	10/29/03	24	80	180	1256	18	0.65	
TP-10A	10/29/03	24	80	180	1257	19	0.63	
TP-10A	10/29/03	24	80	180	1258	20	0.605	
TP-10A	10/29/03	24	80	180	1259	21	0.59	
TP-10A	10/29/03	24	80	180	1300	22	0.58	

TABLE C-1

Trench Percolation Test Results

Trench	Test Date	Test Pit Depth (inches)	Approximate Surface Area (square feet)	Amount of Water Added (gallons)	Time During test	Elapsed Time (minutes)	Depth to Water (feet)	Results/Notes
TP-10A	10/29/03	24	80	180	1301	23	0.55	
TP-10A	10/29/03	24	80	180	1302	24	0.54	
TP-10A	10/29/03	24	80	180	1303	25	0.52	
TP-10A	10/29/03	24	80	180	1304	26	0.51	
TP-10A	10/29/03	24	80	180	1305	27	0.46	
TP-10A	10/29/03	24	80	180	1306	28	0.475	
TP-10A	10/29/03	24	80	180	1307	29	0.46	
TP-10A	10/29/03	24	80	180	1308	30	0.445	
TP-10A	10/29/03	24	80	180	1309	31	0.43	
TP-10A	10/29/03	24	80	180	1310	32	0.415	
TP-10A	10/29/03	24	80	180	1311	33	0.40	
TP-10A	10/29/03	24	80	180	1312	34	0.385	

TABLE C-1

Trench Percolation Test Results

Trench	Test Date	Test Pit Depth (inches)	Approximate Surface Area (square feet)	Amount of Water Added (gallons)	Time During test	Elapsed Time (minutes)	Depth to Water (feet)	Results/Notes
TP-10A	10/29/03	24	80	180	1313	35	0.37	
TP-10A	10/29/03	24	80	180	1314	36	0.355	
TP-10A	10/29/03	24	80	180	1315	37	0.34	
TP-10A	10/29/03	24	80	180	1316	38	0.33	
TP-10A	10/29/03	24	80	180	1317	39	0.315	
TP-10A	10/29/03	24	80	180	1318	40	0.295	
TP-10A	10/29/03	24	80	180	1319	41	0.285	
TP-10A	10/29/03	24	80	180	1320	42	0.27	
TP-10A	10/29/03	24	80	180	1321	43	0.25	
TP-10A	10/29/03	24	80	180	1322	44	0.235	
TP-10A	10/29/03	24	80	180	1323	45	0.22	
TP-10A	10/29/03	24	80	180	1324	46	0.20	

TABLE C-1
 Trench Percolation Test Results

Trench	Test Date	Test Pit Depth (inches)	Approximate Surface Area (square feet)	Amount of Water Added (gallons)	Time During test	Elapsed Time (minutes)	Depth to Water (feet)	Results/Notes
TP-12A	10/29/03	24	104	180	0715	0	0.58	-Depth of water bgs (below ground surface)- not total depth of water -No seepage into adjacent trenches -Water gone at 0818 -Infiltration Rate = (180 gal/104 square feet)/63 minutes x 1440 = (40 gal/square feet)/day
TP-12A	10/29/03	24	104	180	0720	5	0.75	
TP-12A	10/29/03	24	104	180	0725	10	0.79	
TP-12A	10/29/03	24	104	180	0730	15	0.90	
TP-12A	10/29/03	24	104	180	0735	20	1.00	
TP-12A	10/29/03	24	104	180	0740	25	1.08	
TP-12A	10/29/03	24	104	180	0745	30	1.17	
TP-12A	10/29/03	24	104	180	0750	35	1.25	
TP-12A	10/29/03	24	104	180	0755	40	1.33	
TP-12A	10/29/03	24	104	180	0800	45	1.42	
TP-12A	10/29/03	24	104	180	0805	50	1.50	
TP-12A	10/29/03	24	104	180	0810	55	1.63	

TABLE C-1
 Trench Percolation Test Results

Trench	Test Date	Test Pit Depth (inches)	Approximate Surface Area (square feet)	Amount of Water Added (gallons)	Time During test	Elapsed Time (minutes)	Depth to Water (feet)	Results/Notes
TP-12A	10/29/03	24	104	180	0814	59	1.73	
TP-12A	10/29/03	24	104	180	0815	60	1.81	
TP-12A	10/29/03	24	104	180	0818	63	1.83	
TP-13A	10/29/03	24	104	90	0720	0	0	-Depth to water below ground surface (bgs) -No seepage into adjacent trenches -Infiltration Rate = (90 gal/104 square feet)/180 minutes x 1440 = (7 gal/square feet)/day
TP-13A	10/29/03	24	104	90	0722	2	0.67	
TP-13A	10/29/03	24	104	90	0727	7	0.70	
TP-13A	10/29/03	24	104	90	0732	12	0.77	
TP-13A	10/29/03	24	104	90	0737	17	0.81	
TP-13A	10/29/03	24	104	90	0742	22	0.83	
TP-13A	10/29/03	24	104	90	0747	27	0.88	
TP-13A	10/29/03	24	104	90	0752	32	0.90	
TP-13A	10/29/03	24	104	90	0757	37	0.94	

TABLE C-1

Trench Percolation Test Results

Trench	Test Date	Test Pit Depth (inches)	Approximate Surface Area (square feet)	Amount of Water Added (gallons)	Time During test	Elapsed Time (minutes)	Depth to Water (feet)	Results/Notes
TP-13A	10/29/03	24	104	90	0802	42	0.96	
TP-13A	10/29/03	24	104	90	0807	47	0.99	
TP-13A	10/29/03	24	104	90	0812	52	1.02	
TP-13A	10/29/03	24	104	90	0817	57	1.06	
TP-13A	10/29/03	24	104	90	0822	62	1.08	
TP-13A	10/29/03	24	104	90	0827	67	1.11	
TP-13A	10/29/03	24	104	90	0832	72	1.15	
TP-13A	10/29/03	24	104	90	0837	77	1.18	
TP-13A	10/29/03	24	104	90	0842	82	1.20	
TP-13A	10/29/03	24	104	90	0847	87	1.23	
TP-13A	10/29/03	24	104	90	0852	92	1.26	
TP-13A	10/29/03	24	104	90	0857	97	1.28	

TABLE C-1

Trench Percolation Test Results

Trench	Test Date	Test Pit Depth (inches)	Approximate Surface Area (square feet)	Amount of Water Added (gallons)	Time During test	Elapsed Time (minutes)	Depth to Water (feet)	Results/Notes
TP-13A	10/29/03	24	104	90	0902	102	1.32	
TP-13A	10/29/03	24	104	90	0907	107	1.35	
TP-13A	10/29/03	24	104	90	0912	112	1.38	
TP-13A	10/29/03	24	104	90	0917	117	1.40	
TP-13A	10/29/03	24	104	90	0922	122	1.44	
TP-13A	10/29/03	24	104	90	0927	127	1.47	
TP-13A	10/29/03	24	104	90	0932	132	1.50	
TP-13A	10/29/03	24	104	90	0937	137	1.53	
TP-13A	10/29/03	24	104	90	0942	142	1.55	
TP-13A	10/29/03	24	104	90	0947	147	1.59	
TP-13A	10/29/03	24	104	90	0952	152	1.63	
TP-13A	10/29/03	24	104	90	0957	157	1.67	

TABLE C-1 Trench Percolation Test Results								
Trench	Test Date	Test Pit Depth (inches)	Approximate Surface Area (square feet)	Amount of Water Added (gallons)	Time During test	Elapsed Time (minutes)	Depth to Water (feet)	Results/Notes
TP-13A	10/29/03	24	104	90	1002	162	1.73	
TP-13A	10/29/03	24	104	90	1007	167	1.77	
TP-13A	10/29/03	24	104	90	1012	172	1.84	
TP-13A	10/29/03	24	104	90	1017	177	1.93	
TP-13A	10/29/03	24	104	90	1019	179	2	
TP-13A	10/29/03	24	104	90	1020	180	2	

TABLE C-1 Trench Percolation Test Results								
Trench	Test Date	Test Pit Depth (inches)	Approximate Surface Area (square feet)	Amount of Water Added (gallons)	Time During test	Elapsed Time (minutes)	Depth to Water (feet)	Results/Notes
TP-24A	10/29/03	36	95	190	1343	0	0	- Wet in four foot trench, area affected: 4' x 1.8' - Six foot trench dry -Infiltration Rate= (190 gal/95 square feet)/133 minute x 1440= (22 gal/square feet)/day
TP-24A	10/29/03	36	95	190	1345	2	1.55	
TP-24A	10/29/03	36	95	190	1347	4	1.47	
TP-24A	10/29/03	36	95	190	1349	6	1.40	
TP-24A	10/29/03	36	95	190	1351	8	1.36	
TP-24A	10/29/03	36	95	190	1353	10	1.32	
TP-24A	10/29/03	36	95	190	1355	12	1.28	
TP-24A	10/29/03	36	95	190	1357	14	1.25	
TP-24A	10/29/03	36	95	190	1359	16	1.22	
TP-24A	10/29/03	36	95	190	1401	18	1.19	
TP-24A	10/29/03	36	95	190	1403	20	1.16	
TP-24A	10/29/03	36	95	190	1405	22	1.135	

TABLE C-1
 Trench Percolation Test Results

Trench	Test Date	Test Pit Depth (inches)	Approximate Surface Area (square feet)	Amount of Water Added (gallons)	Time During test	Elapsed Time (minutes)	Depth to Water (feet)	Results/Notes
TP-24A	10/29/03	36	95	190	1407	24	1.10	
TP-24A	10/29/03	36	95	190	1409	26	1.085	
TP-24A	10/29/03	36	95	190	1411	28	1.065	
TP-24A	10/29/03	36	95	190	1413	30	1.04	
TP-24A	10/29/03	36	95	190	1415	32	1.02	
TP-24A	10/29/03	36	95	190	1417	34	1.00	
TP-24A	10/29/03	36	95	190	1419	36	0.98	
TP-24A	10/29/03	36	95	190	1421	38	0.96	
TP-24A	10/29/03	36	95	190	1423	40	0.94	
TP-24A	10/29/03	36	95	190	1425	42	0.92	
TP-24A	10/29/03	36	95	190	1427	44	0.90	
TP-24A	10/29/03	36	95	190	1429	46	0.89	

TABLE C-1

Trench Percolation Test Results

Trench	Test Date	Test Pit Depth (inches)	Approximate Surface Area (square feet)	Amount of Water Added (gallons)	Time During test	Elapsed Time (minutes)	Depth to Water (feet)	Results/Notes
TP-24A	10/29/03	36	95	190	1431	48	0.87	
TP-24A	10/29/03	36	95	190	1433	50	0.85	
TP-24A	10/29/03	36	95	190	1435	52	0.84	
TP-24A	10/29/03	36	95	190	1437	54	0.825	
TP-24A	10/29/03	36	95	190	1439	56	0.80	
TP-24A	10/29/03	36	95	190	1441	58	0.79	
TP-24A	10/29/03	36	95	190	1443	60	0.775	
TP-24A	10/29/03	36	95	190	1445	62	0.76	
TP-24A	10/29/03	36	95	190	1447	64	0.74	
TP-24A	10/29/03	36	95	190	1449	66	0.725	
TP-24A	10/29/03	36	95	190	1451	68	0.71	
TP-24A	10/29/03	36	95	190	1453	70	0.695	

TABLE C-1 Trench Percolation Test Results								
Trench	Test Date	Test Pit Depth (inches)	Approximate Surface Area (square feet)	Amount of Water Added (gallons)	Time During test	Elapsed Time (minutes)	Depth to Water (feet)	Results/Notes
TP-24A	10/29/03	36	95	190	1455	72	0.68	
TP-24A	10/29/03	36	95	190	1457	74	0.665	
TP-24A	10/29/03	36	95	190	1459	76	0.65	
TP-24A	10/29/03	36	95	190	1501	78	0.635	
TP-24A	10/29/03	36	95	190	1503	80	0.615	
TP-24A	10/29/03	36	95	190	1505	82	0.60	
TP-24A	10/29/03	36	95	190	1507	84	0.59	
TP-24A	10/29/03	36	95	190	1509	86	0.575	
TP-24A	10/29/03	36	95	190	1511	88	0.565	
TP-24A	10/29/03	36	95	190	1513	90	0.545	
TP-24A	10/29/03	36	95	190	1515	92	0.535	
TP-24A	10/29/03	36	95	190	1517	94	0.515	

TABLE C-1 Trench Percolation Test Results								
Trench	Test Date	Test Pit Depth (inches)	Approximate Surface Area (square feet)	Amount of Water Added (gallons)	Time During test	Elapsed Time (minutes)	Depth to Water (feet)	Results/Notes
TP-24A	10/29/03	36	95	190	1519	96	0.50	
TP-24A	10/29/03	36	95	190	1541	118	0.30	
TP-24A	10/29/03	36	95	190	1546	123	0.24	
TP-24A	10/29/03	36	95	190	1551	128	0.14	
TP-24A	10/29/03	36	95	190	1556	133	0.00	

Appendix D

Spring Locations and Descriptions

Spring Locations and Descriptions

In early December 2003, AEG conducted a walkover inspection of the properties on and adjacent to the Project. The inspection was primarily of the low areas and drainage systems in which springs might be located. The initial inspection was conducted before any winter rains, and at that time springs were easily detected. A later inspection on December 16, 2003 was after the winter rains had started, and low flow had begun to appear in several of the gullies. Spring locations are illustrated by **Figure 3** within the main body of this document. A description of each spring is as follows:

- Spring 1 This spring was located at the time the percolation testing was conducted. This spring was essentially a seep at the time it was located. It extends along the base of the gully for a distance of roughly 20 to 30 feet, and appears to be fed primarily from the southeast side of the gully. There is a Home Depot flag at this location.
- Spring 2 This is a spring in the steep gully just south of the Haueter residence. It could be related to water being discharged by the Haueter residence including irrigation water used by them.
- Spring 3 This spring is in the bottom of the steep gully east of the Haueter residence. It is probably related to the long abandoned London Quartz Mine, which is located in the west side of this same gully.

Springs 4 through 8 were located on December 16, 2003, after the rainy season had started.

- Spring 4 Small trickle in bottom of gully that is incised downstream of this point. Spring is at upper end of gully that is southwest of Spring 6. A cutoff trench was placed upslope of the nearby road just north of this location to intercept and divert near surface drainage.
- Spring 5 Downstream of Spring 4. Trickle of water coming from side of gully. At a distance of approximately 100 yards downstream of this point there is flow in gully.
- Spring 6 This small trickle is from a small side gully within the large gully on the west side of the Pioneer Mine. This small gully is southwest of the mine location.

- Spring 7 There is a small area of seepage downslope of Trench TP-26. Vegetation indicates this to be a probable seepage area. There is a Home Depot flag approximately 100 feet downslope. Channel below this point is incised approximately four feet.
- Spring 8 There is an area of apparent seepage as indicated by vegetation at a location that is approximately 1/4 mile downstream of Spring 7. This appears to be off the Matulich property. There is also another area of seepage approximately another 100 feet downstream.

Appendix E

Water Balance Calculations

Water Balance for Seasonal Storage and Disposal Sizing Lone Rancheria Casino & Hotel

INITIAL CONDITIONS

90,000 Wastewater flow (gpd)
 0% Percent RDI/I

	Capacity (gpd)	Area (acre)	Depth (ft)	Capacity (MG)
Leachfield	24,926	2.86		
Sprayfield	95,873	13.7		
Landscaping	9,801	2.0		
Storage		0.0	10.0	10.38

SEASONAL OPERATIONAL USE			
Period	Landscapin	Sprayfield	Leachfield
% in use during wet weather (Nov-Mar)	0%	100%	50%
% in use during dry weather (Apr-Oct)	100%	100%	100%

0.2 Soil application (hydraulic loading) rate for percolation (gpd/ft²)

WATER BALANCE														
Month (-)	Days (-)	In from rainfall (MG)	In from RDI/I (MG)	In from wastewater (MG)	Net in (MG)	Out to evaporation (MG)	Out to landscaping (MG)	Out to wint landscapin (MG)	Out to sprayfield (MG)	Out to wint sprayfield (MG)	Out to leachfield (MG)	Net out (MG)	Net (MG)	Accum storage (MG)
November	30	0.00	0.00	2.70	2.70	0.00	0.00	0.00	0.00	0.34	0.37	0.72	1.98	1.98
December	31	0.00	0.00	2.79	2.79	0.00	0.00	0.00	0.00	0.13	0.39	0.51	2.28	4.26
January	31	0.00	0.00	2.79	2.79	0.00	0.00	0.00	0.00	0.18	0.39	0.56	2.23	6.49
February	28	0.00	0.00	2.52	2.52	0.00	0.00	0.00	0.00	0.27	0.35	0.62	1.90	8.39
March	31	0.00	0.00	2.79	2.79	0.00	0.00	0.00	0.00	0.43	0.39	0.82	1.97	10.37
April	30	0.00	0.00	2.70	2.70	0.00	0.26	0.00	1.68	0.00	0.75	2.69	0.01	10.38
May	31	0.00	0.00	2.79	2.79	0.00	0.50	0.00	4.21	0.00	0.77	5.48	-2.69	7.69
June	30	0.00	0.00	2.70	2.70	0.00	0.68	0.00	6.76	0.00	0.75	8.19	-5.49	2.20
July	31	0.00	0.00	2.79	2.79	0.00	0.80	0.00	9.23	0.00	0.77	10.80	-8.01	0.00
August	31	0.00	0.00	2.79	2.79	0.00	0.69	0.00	6.88	0.00	0.77	8.34	-5.55	0.00
September	30	0.00	0.00	2.70	2.70	0.00	0.46	0.00	3.68	0.00	0.75	4.89	-2.19	0.00
October	31	0.00	0.00	2.79	2.79	0.00	0.20	0.00	1.20	0.00	0.77	2.17	0.62	0.62
Average	30.4	0.00	0.00	2.74	2.74	0.00	0.30	0.00	2.80	0.11	0.60	3.82	-1.08	4
Total	365	0.00	0.00	32.85	32.85	0.00	3.58	0.00	33.65	1.34	7.22	45.79	-12.94	52
Max	31	0.00	0.00	2.79	2.79	0.00	0.80	0.00	9.23	0.43	0.77	10.80	2.28	10.38
Min	28	0.00	0.00	2.52	2.52	0.00	0.00	0.00	0.00	0.00	0.35	0.51	-8.01	0.00

Water Balance for Seasonal Storage and Disposal Sizing Shingle Springs Rancheria

Sample Calculation

INITIAL CONDITIONS

80,000 Wastewater flow (gpd)
 0% Percent RDI/I

	Capacity (gpd)	Area (acre)	Depth (ft)	Capacity (MG)
Leachfield	24,926	2.9		
Sprayfield	95,873	13.7		
Landscaping	9,801	2.0		
Storage		0.0	10.0	8.86

SEASONAL OPERATIONAL USE	Period	Landscapin	Sprayfield	Leachfield
% in use during wet weather (Nov-Mar)		0%	100%	50%
% in use during dry weather (Apr-Oct)		100%	100%	100%

0.2 Soil application (hydraulic loading) rate for percolation (gpd/ft²)

WATER BALANCE														
Month (-)	Days (-)	In from rainfall (MG)	In from RDI/I (MG)	In from wastewater (MG)	Net in (MG)	Out to evaporation (MG)	Out to landscaping (MG)	Out to winte landscaping (MG)	Out to sprayfield (MG)	Out to winte sprayfield (MG)	Out to leachfield (MG)	Net out (MG)	Net (MG)	Accum storage (MG)
November	30	0.00	0.00	2.40	2.40	0.00	0.00	0.00	0.00	0.34	0.37	0.72	1.68	1.68
December	31	0.00	0.00	2.48	2.48	0.00	0.00	0.00	0.00	0.13	0.39	0.51	1.97	3.65
January	31	0.00	0.00	2.48	2.48	0.00	0.00	0.00	0.00	0.18	0.39	0.56	1.92	5.57
February	28	0.00	0.00	2.24	2.24	0.00	0.00	0.00	6.00	0.27	0.35	0.62	1.62	7.19
March	31	0.00	0.00	2.48	2.48	0.00	0.00	0.00	0.00	0.43	0.39	0.82	1.66	8.86
April	30	0.00	0.00	2.40	2.40	0.00	0.26	0.00	1.68	0.00	0.75	2.69	-0.29	8.57
May	31	0.00	0.00	2.48	2.48	0.00	0.50	0.00	4.21	0.00	0.77	5.48	-3.00	5.57
June	30	0.00	0.00	2.40	2.40	0.00	0.68	0.00	6.76	0.00	0.75	8.19	-5.79	0.00
July	31	0.00	0.00	2.48	2.48	0.00	0.80	0.00	9.23	0.00	0.77	10.80	-8.32	0.00
August	31	0.00	0.00	2.48	2.48	0.00	0.69	0.00	6.88	0.00	0.77	8.34	-5.86	0.00
September	30	0.00	0.00	2.40	2.40	0.00	0.46	0.00	3.68	0.00	0.75	4.89	-2.49	0.00
October	31	0.00	0.00	2.48	2.48	0.00	0.20	0.00	1.20	0.00	0.77	2.17	0.31	0.31
Average	30.4	0.00	0.00	2.43	2.43	0.00	0.30	0.00	2.80	0.11	0.60	3.82	-1.38	3
Total	365	0.00	0.00	29.20	29.20	0.00	3.58	0.00	33.65	1.34	7.22	45.79	-16.59	41
Max	31	0.00	0.00	2.48	2.48	0.00	0.80	0.00	9.23	0.43	0.77	10.80	1.97	8.86
Min	28	0.00	0.00	2.24	2.24	0.00	0.00	0.00	0.00	0.00	0.35	0.51	-8.32	0.00

Water Balance for Seasonal Storage and Disposal Sizing Shingle Springs Rancheria

Sample Calculation

INITIAL CONDITIONS

40,000 Wastewater flow (gpd)
 0% Percent RDI/I

	Capacity (gpd)	Area (acre)	Depth (ft)	Capacity (MG)
Leachfield	0	0.0		
Sprayfield	95,873	13.7		
Landscaping	9,801	2.0		
Storage		0.0	10.0	4.70

SEASONAL OPERATIONAL USE				
	Period	Landscapin	Sprayfield	Leachfield
% in use during wet weather (Nov-Mar)		0%	100%	100%
% in use during dry weather (Apr-Oct)		100%	100%	25%

0.2 Soil application (hydraulic loading) rate for percolation (gpd/ft²)

WATER BALANCE

Month (-)	Days (-)	In from rainfall (MG)	In from RDI/I (MG)	In from wastewater (MG)	Net in (MG)	Out to evaporation (MG)	Out to landscaping (MG)	Out to winter landscaping (MG)	Out to sprayfield (MG)	Out to winter sprayfield (MG)	Out to leachfield (MG)	Net out (MG)	Net (MG)	Accum storage (MG)
November	30	0.00	0.00	1.20	1.20	0.00	0.00	0.00	0.00	0.34	0.00	0.34	0.86	0.86
December	31	0.00	0.00	1.24	1.24	0.00	0.00	0.00	0.00	0.13	0.00	0.13	1.11	1.97
January	31	0.00	0.00	1.24	1.24	0.00	0.00	0.00	0.00	0.18	0.00	0.18	1.06	3.04
February	28	0.00	0.00	1.12	1.12	0.00	0.00	0.00	0.00	0.27	0.00	0.27	0.85	3.89
March	31	0.00	0.00	1.24	1.24	0.00	0.00	0.00	0.00	0.43	0.00	0.43	0.81	4.70
April	30	0.00	0.00	1.20	1.20	0.00	0.26	0.00	1.68	0.00	0.00	1.94	-0.74	3.96
May	31	0.00	0.00	1.24	1.24	0.00	0.50	0.00	4.21	0.00	0.00	4.71	-3.47	0.49
June	30	0.00	0.00	1.20	1.20	0.00	0.68	0.00	6.76	0.00	0.00	7.44	-6.24	0.00
July	31	0.00	0.00	1.24	1.24	0.00	0.80	0.00	9.23	0.00	0.00	10.03	-8.79	0.00
August	31	0.00	0.00	1.24	1.24	0.00	0.69	0.00	6.88	0.00	0.00	7.57	-6.33	0.00
September	30	0.00	0.00	1.20	1.20	0.00	0.46	0.00	3.68	0.00	0.00	4.14	-2.94	0.00
October	31	0.00	0.00	1.24	1.24	0.00	0.20	0.00	1.20	0.00	0.00	1.40	-0.16	0.00
Average	30.4	0.00	0.00	1.22	1.22	0.00	0.30	0.00	2.80	0.11	0.00	3.21	-2.00	2
Total	365	0.00	0.00	14.60	14.60	0.00	3.58	0.00	33.65	1.34	0.00	38.57	-23.97	19
Max	31	0.00	0.00	1.24	1.24	0.00	0.80	0.00	9.23	0.43	0.00	10.03	1.11	4.70
Min	28	0.00	0.00	1.12	1.12	0.00	0.00	0.00	0.00	0.00	0.00	0.13	-8.79	0.00